



Toyota Tacoma Economy Bed Rack

4810

Kit Contents:

<u>Item</u>	<u>Qty</u>	<u>Item</u>	<u>Qty</u>
3/8" x 1-1/4" Hex Bolts	8	Platform Rack	1
3/8" SAE Flat Washer	24	3/8" Nyloc Nut	16
Mounting Brackets	2	Channel Plate Assembly	4
WP #4811 – Bed Rack Channel Tie Bar	1		

Installation Instructions:

1. Locate the channels/factory track rails along the inside of your Tacoma truck bed.
2. Remove the factory channel plastic end caps nearest the tailgate. One should be removed from each channel.
3. Insert [2] Channel Plate Assemblies into each factory channel from the tailgate end. Orient the Plates so that the treaded portion of the Carriage Bolts are pointing out through the channel opening toward the center of the truck bed. There may be some resistance while sliding the Carriage Bolt head past the first factory mounting screw inside the channel. Push hard or lightly tap with a hammer to pass the Carriage Bolt head by the first screw. If the Channel Plate Assembly will not move past the first screw, you may have to remove the screw for clearance and replace the screw after inserting both Channel Plate Assemblies into the factory channel.
4. Take a large mounting bracket, with formed lip down and "WP" Logo toward the rear of the vehicle. Align the Channel Plates with one toward the front of the channel and the other toward the rear of the channel. Position the Channel Plates and Mounting Bracket so that the threaded bolts will pass through the 2 holes in the front, and 2 holes in the rear of the mounting bracket. The lower formed lip will sit inside the channel.
5. Loosely thread/start a washer and Nyloc nut on all 4 studs (there are two bolts at each end). Leave loose enough for mount to slide.
6. Repeat steps 3-5 for opposite side of the truck bed.
7. Align mounting brackets front-to-rear. The rear edge of the mounting brackets should be about 1-1/2" in from the end of the metal channels (the 1-1/2" measurement is based on a 5ft. bed).
8. If you choose to install the reinforcement Tie Bar (Warrior P/N - 4811) it should be installed at this time. See page 3 for Tie Bar installation instructions.
9. Tighten channel mounting hardware.



10. Carefully set the platform rack on top of mounting brackets with angled round tube facing towards the rear of the vehicle and the corner plates positioned on the bottom side of the rack. Make sure to center the rack on the two mounting brackets.
11. On one side of the rack, position [4] 3/8" x 1-1/4" hex bolts. First place a washer on each bolt, then proceed to place the bolts through the platform rack in the locations shown below (**Figure 1**). The bolts ***MUST*** be placed through the 2 ***outer-most*** mounting slots closest to the bed rail. For best load distribution, the front-to-back placement of the bolts should be through the center row (of 5) as shown. However, if you have a particular application in which you would like to shift the platform forward or backward on the mounts, you may use alternate rows of mounting slots (be aware the bolts must always be in the ***outer-most*** slots, and that the weight distribution of the loaded rack may be uneven, and potentially less stable). On the underside of the mount place a washer on each bolt and loosely thread on the Nyloc nuts.

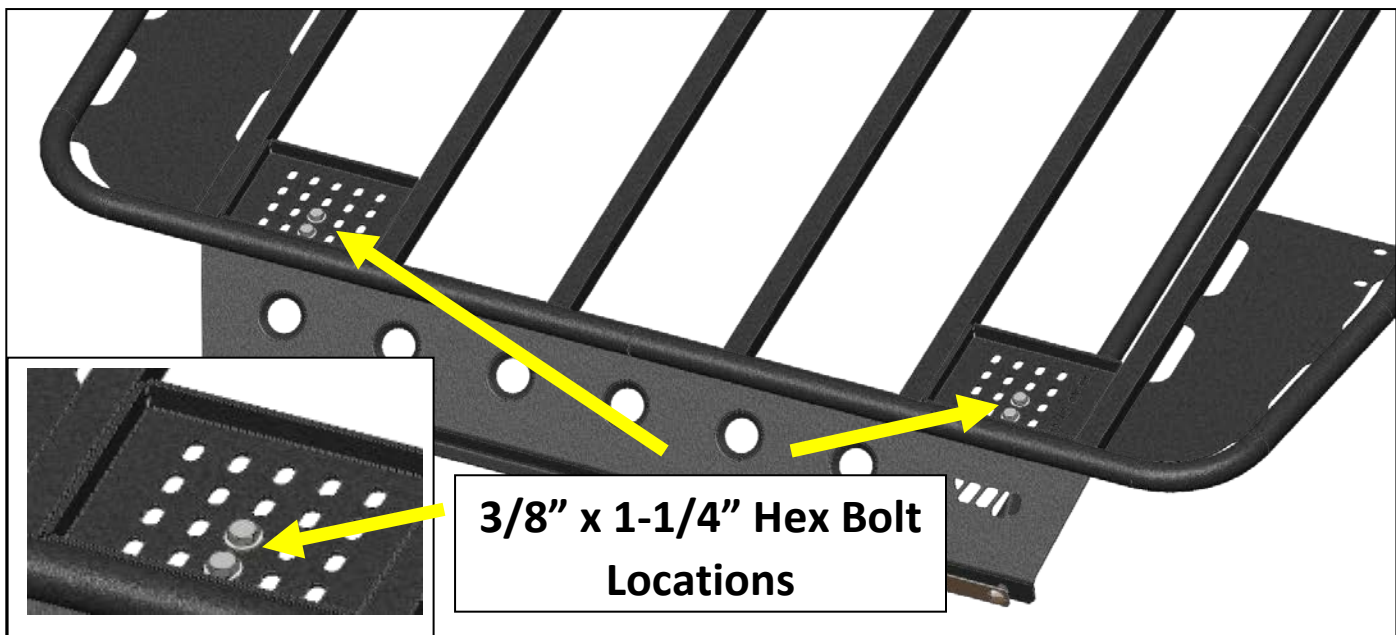

Figure 1 – Platform Hex Bolt and Load Plate Locations

12. Repeat step 11 for opposite side.
13. Visually align. (Loosen and adjust the Mount position if necessary)
14. Tighten all hardware.
15. Installation Complete. Periodically check all hardware and re-tighten if necessary.



Optional 4811 Tie Bar

The Tie Bar is an optional accessory that can be installed in conjunction with your Warrior Products 4810 Economy Bed Rack to provide reinforcement and rigidity for the truck bed sides. This reinforcement is beneficial if you frequently operate in moderate to aggressive off-road driving conditions. The Tie Bar should be positioned at the rear-most Bed Rack mounting points for maximum reinforcement benefit, however you may install the Tie Bar at either of the two Bed Rack mounting points that you choose. For additional reinforcement you can purchase an additional Tie Bar (WP Part# 4811) to reinforce BOTH the front and rear Bed Rack mounting points. Please note that if you choose to install the Tie Bar, the clearance below the rack for cargo will be reduced, however, you can easily remove the Tie Bar with a 9/16" wrench or socket if you have a situation where you need the additional cargo clearance below the rack system.

Installation Instructions:

1. Choose the front or rear mounting points of the Bed Rack for your Tie Bar installation. As noted above, installation of the Tie Bar at the rear Bed Rack mounting point will provide the maximum reinforcement benefit. These instructions illustrate rear installation, but the process is the same for either point.
2. Loosen the [2] nuts per side (either front or rear) that attach the Bed Rack mount to the Channel Bracket. You will loosen a total of [4] nuts for each Tie Bar installation.
3. Locate the "long" slots on the Tie Bar end plates and slide them over the Carriage Bolt thread between the washer and the Bed Rack Mount. See **Fig. 1**.
4. Rotate the Tie Bar up so that the second "short" slot is aligned with the second Carriage Bolt thread. See **Fig. 1**.
5. Slide the Tie Bar "short" slot over the second set of Carriage Bolt threads (with the end plate between the washer and the Bed Rack Mount). Slide the Tie Bar until the slot is fully seated against the Carriage bolt threads. The end plate should be positioned as shown, with the Tie Bar centered between the Carriage Bolt threads. See **Fig. 1**.

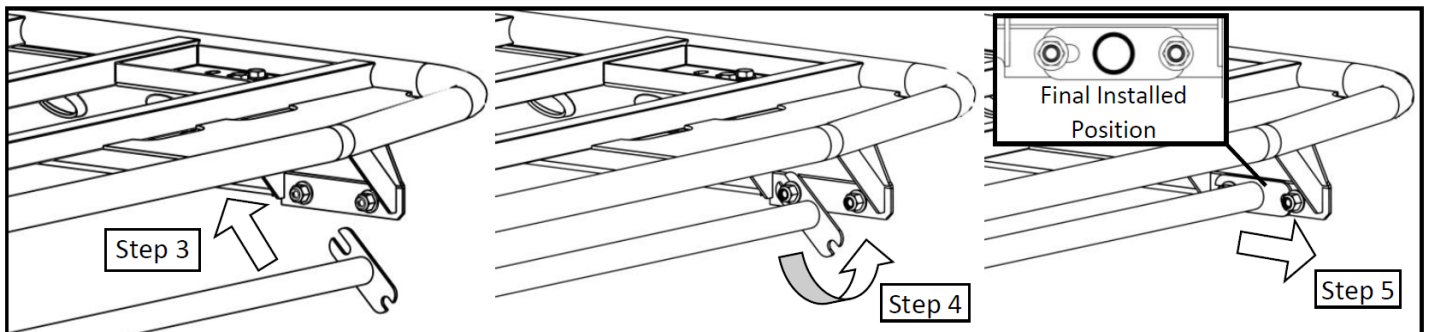

6. Tighten all [4] nuts the installation is complete.