

7929 Lincoln Ave. Riverside, CA 92504
Phone: 951.689.ICON Fax: 951.689.1016

PART #	DESCRIPTION
56104	2007-UP FJ CRUISER / 2003-UP 4RUNNER HYDRAULIC BUMP STOP KIT

COMPONENTS INCLUDED	
(2) 204906 2.0 AIR BUMP 1.75 TRAVEL 1:1 (2) 154021 FJ/4RNR BUMP STOP MOUNT	(1) 56104H HARDWARE KIT
HARDWARE INCLUDED	
56104H HARDWARE KIT	
(2) 150113 WASHER 2.750 X .600 X .135 CSUNK (2) 294002 NUT PLATE 3/8-16 X 2.5 (2) 605052 1/4-20 NYLOCK NUT	(2) 605057 1/4-20 X 2.000 SCREW (2) 605115 3/8-16 X 1.500 FHSCS SS 18-8 (2) 605970 VIBRATITE ANTI SEIZE TUBE
TOOLS REQUIRED	
JACK JACK STANDS GRINDER W/ CUT-OFF WHEEL 7/32" ALLEN WRENCH TORQUE WRENCH	10MM SOCKET / WRENCH 19MM SOCKET / WRENCH 17MM SOCKET / WRENCH 7/16" SOCKET / WRENCH
TECH NOTES	
<p>1. APPLY ANTISEIZE TO THE BUMP STOP CYLINDER BEFORE INSERTING INTO THE BRACKET. FAILURE TO APPLY ANTISEIZE MAY CAUSE BUMP STOP TO GET STUCK IN THE BRACKET.</p> <p>2. YOUR ICON BUMP STOP ASSEMBLIES COME FACTORY CHARGED TO 100 PSI. PLEASE CONSULT ICON PRIOR TO MAKING ANY NITROGEN PRESSURE CHANGES.</p> <p>3. AFTER THE FIRST FEW HARD BUMP STOP STRIKES, RETIGHTEN THE LOWER BUMP STOP STRIKER PLATE.</p>	



WARNING!
<p>** READ ALL INSTRUCTIONS THOROUGHLY FROM START TO FINISH BEFORE BEGINNING INSTALLATION! IF THESE INSTRUCTIONS ARE NOT PROPERLY FOLLOWED SEVERE FRAME, SUSPENSION AND TIRE DAMAGE MAY RESULT TO THE VEHICLE!</p> <p>** ICON VEHICLE DYNAMICS RECOMMENDS THAT YOU EXERCISE EXTREME CAUTION WHEN WORKING UNDER A VEHICLE THAT IS SUPPORTED WITH JACK STANDS.</p> <p>** ICON VEHICLE DYNAMICS RECOMMENDS ALL INSTALLTION TO BE PERFORMED BY A PROFESSIONAL SHOP/SERVICE TECHNICIAN. PRODUCT FAILURE CAUSED BY IMPROPER INSTALLATION WILL NOT BE COVERED UNDER ICON'S WARRANTY POLICY.</p>

INSTALLATION

- Using a properly rated jack, raise the rear of the vehicle and support the frame rails with jack stands. Ensure the jack stands are secure and set properly before lowering the jack. NEVER WORK UNDER AN UNSUPPORTED VEHICLE. Remove the front wheels.
- Disconnect the rear track bar from the differential. (19mm)
- Support axle assembly with floor jack. Remove bolt retaining the bottom of the rear shocks (17mm) and slide the bottom of the shock off the mounting stud.
- Carefully lower the axle assembly. Make sure the free end of the shock does not catch on anything while lowering. Lower until there is room to remove the rear coils. Due to bushing stiffness it may be required that you push down on the axle assembly or loosen the control arm pivots.
- Remove coils and cone shaped upper spring seat. [FIGURE 1]



FIG.1



FIG.2

- Assemble air bump into mount. Apply antiseize to the bump stop cylinder then slide the bump stop in to the mount until the step on the cylinder touches the center tube of the mount. Install 1/4" bolt and nut in pinch tubes of mount and tighten. [Torque to 10 ft-lbs]. DO NOT OVER TIGHTEN. Make sure the air bump is secure in the mount.
- Install lower striker pad on axle spring seat. The striker plate retainer nut plate supplied can be bent for accessibility from the underside of the formed spring seat on the axle. Using the supplied flat head bolt secure the striker plate with chamfer upward through the hole in the middle of the lower spring seat. [Torque to 20 ft-lbs] [FIGURE 2]

8. Reinstall coil with the air bump assembly in place of rubber cone shaped spring seat. [FIGURE 3 & 4]

FIG.3



FIG.4

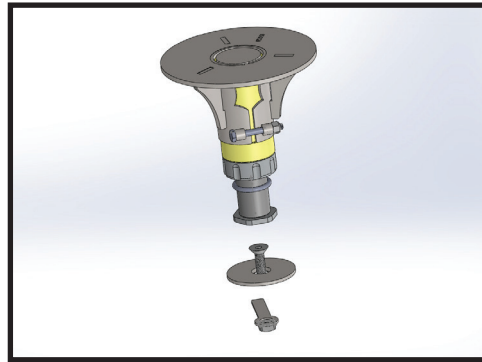

9. Slowly raise axle until spring is seated in its mounts. Make sure the upper air bump mount is properly centered in the upper depression in the frame for the coil and that the lower pigtail of the spring is properly oriented on the seat on the axle.

10. Continue to raise the axle until you can reconnect the lower end of the shock.

11. Reconnect the sway bar. (10mm)

12. Safely remove the jack stands and put the vehicle back on the ground. If any links were loosened, retighten them to factory specs at ride height on the ground to prevent bushing bind.

13. Reconnect the track bar and torque hardware to factory specs. (19mm)

14. Test drive the vehicle, making sure to listen and feel for any abnormal characteristics. Bumpstop engagement over big bumps, whoops, or similar terrain will be normal. This can be identified by a prominent "click" sound during suspension travel. Inspect and double check hardware after first 100 miles of driving and periodically thereafter. It is important to routinely check the lower bump stop striker plate for tightness, as this plate will conform to the factory mount after hard bump contact.

VERIFY ALL FASTENERS ARE PROPERLY TORQUED BEFORE DRIVING VEHICLE.

RETORQUE ALL NUTS, BOLTS AND LUGS AFTER 100 MILES AND PERIODICALLY THEREAFTER.

ICON VEHICLE DYNAMICS

PERFORMANCE SUSPENSION SYSTEMS AND SHOCK ABSORBERS

7929 Lincoln Ave. Riverside, CA 92504 Phone: 951.689.ICON Fax: 951.689.1016
www.iconvehicledynamics.com



FOLLOW US ON FACEBOOK!



2.0 ALUMINUM SERIES TECHNICAL INFORMATION

MAINTENANCE

ICON shock absorbers are a high quality rebuildable race style shock absorber designed for optimal performance. With a unit of this caliber on your vehicle, routine maintenance is required to keep them looking and operating in like new condition. Residual oil and assembly lube may be present at all seal paths from the factory out of the box and is considered normal. Pooling of oil however is not acceptable at any time and one should contact the ICON dealer where purchased.

BELOW ARE GUIDELINES BASED ON HOW YOU USE YOUR VEHICLE BUT YOUR MILEAGE MAY VARY:

STREET USE:

- Send in for factory servicing every 40,000 miles or if a leak develops, ride quality decreases, or they begin to make excessive noise.
- Remove any buildup of road salt, mud, or debris from shocks anytime accrued
- Clean with mild soap and water with each oil change or anytime you notice build up.
- Wax the cylinders yearly with automotive wax to prevent corrosion.
- Check nitrogen pressure yearly. (252004 charge needle assembly available at any ICON distributor)

STREET/DIRT:

- Send in for factory servicing every 15,000 miles or if a leak develops, ride quality decreases, or they begin to make excessive noise.
- Clean with mild soap and water with each oil change, offroad trip, or anytime you notice build up.
- Wax the cylinders yearly with automotive wax to prevent corrosion.
- Check nitrogen pressure each dirt outing. (252004 charge needle assembly available at any ICON distributor)

DIRT USE:

- Send in for factory servicing every 1,000 miles.
- Check nitrogen pressure each outing. (252004 charge needle assembly available at any ICON distributor)
- Remove any buildup of mud or debris from shocks after every outing.

SELF-SERVICE:

- Contact ICON for service kits & tools at (951) 689-4266.

PRODUCT REGISTRATION

Please visit: <http://www.iconvehicledynamics.com/tech-support/registration/> to register your product.

ICON VEHICLE DYNAMICS SHOCK ABSORBER WARRANTY

This shock absorber has a 1 year warranty against any manufacturer's defects. If a shock fails within the initial year of ownership, the shock must be shipped to ICON Vehicle Dynamics for inspection and service. If a shock is inspected and it has been determined the shock failed due to neglect, damage caused by improper installation or any other reason besides "normal wear and tear", the owner of said shock is responsible for all service costs. This includes labor, parts, and shipping.

ICON Vehicle Dynamics warrants to the original retail purchaser who owns the vehicle on which the product was originally installed. ICON Vehicle Dynamics does not warrant the product for finish, alterations, modifications and/or installation contrary to ICON Vehicle Dynamics instructions. ICON Vehicle Dynamics products are not designed, nor are they intended to be installed on vehicles used in race applications, for racing purposes or for similar activities. (A "race" is defined as any contest between two or more vehicles, or a contest of one or more vehicles against the clock, whether or not such contest is for a prize). This warranty does not include coverage for police or taxi vehicles, race vehicles, or vehicles used for government or commercial purposes. Also excluded from this warranty are sales outside of the United States of America and Canada.

ICON Vehicle Dynamics' obligation under this warranty is limited to the repair or replacement, at ICON Vehicle Dynamics' discretion, of the defective product. Any and all costs of removal, installation or re-installation, freight charges and incidental or consequential damages are expressly excluded from this warranty. Items that are subject to wear are not considered defective when worn and are not covered.

ICON Vehicle Dynamics components must be installed as a complete kit as shown in our current application guide. Any substitutions or exemptions of required components will immediately void the warranty. Some finish damage may happen to parts during shipping and is not covered under warranty.

This warranty is expressly in lieu of all other warranties expressed or implied. This warranty shall not apply to any product that has been improperly installed, modified or customized subject to accident, negligence, abuse or misuse.

To send a shock in for warranty please visit our website <http://www.iconvehicledynamics.com/tech-support/shock-service/>

ICON VEHICLE DYNAMICS LIMITED LIFETIME WARRANTY

ICON Vehicle Dynamics warrants to the original retail purchaser who owns the vehicle on which the product was originally installed. ICON Vehicle Dynamics does not warrant the product for finish, alterations, modifications and/or installation contrary to ICON Vehicle Dynamics instructions. ICON Vehicle Dynamics products are not designed, nor are they intended to be installed on vehicles used in race applications, for racing purposes or for similar activities. (A "race" is defined as any contest between two or more vehicles, or a contest of one or more vehicles against the clock, whether or not such contest is for a prize). This warranty does not include coverage for police or taxi vehicles, race vehicles, or vehicles used for government or commercial purposes. Also excluded from this warranty are sales outside of the United States of America and Canada.

ICON Vehicle Dynamics' obligation under this warranty is limited to the repair or replacement, at ICON Vehicle Dynamics' discretion, of the defective product. Any and all costs of removal, installation or re-installation, freight charges and incidental or consequential damages are expressly excluded from this warranty. Items that are subject to wear are not considered defective when worn and are not covered.

ICON Vehicle Dynamics components must be installed as a complete kit as shown in our current application guide. Any substitutions or exemptions of required components will immediately void the warranty. Some finish damage may happen to parts during shipping and is not covered under warranty.

This warranty is expressly in lieu of all other warranties expressed or implied. This warranty shall not apply to any product that has been improperly installed, modified or customized subject to accident, negligence, abuse or misuse.