



AR Series Bull Bar

2016-2021 GMC Canyon
2016-2021 Chevy Colorado

**STOP - Verify part and application is correct before proceeding.
If missing part or damage item please customer service directly.**

**Call us at (909) 895-4522 Monday-Friday 9am-6pm PST
Email us at SUPPORT@ARMORDILLOUSA.COM**

ARMORDILLO RECOMMENDS PROFESSIONAL INSTALLATION ON ALL THEIR PRODUCTS

WARNING: When working on ,under or around vehicle exercise caution. If working without a lift check vehicle owners manual for correct jacking points. Always wear safety glasses and ensure a safe working area. Serious injury or death could occur if safety measures are not followed.

PERIODICALLY CHECK TO ENSURE ALL FASTENERS ARE TIGHT AND ALL STRUCTURAL COMPONENTS ARE SOUND CARE

To protect your investment, wax this product after installing. Regular waxing is recommended to add a protective layer over the finish. Do not use any type of polish or wax that may contain abrasives, that could damage the finish.

For stainless steel: Aluminum polish may be used to polish small scratches and scuffs on the finish.
Mild soap may be used to clean bull guard.

For color finishes: Regular waxing is recommended to add a protective layer over the finish.
Mild soap may be used to clean the bull guard.

ARMORDILLO products are designed as decorative accessories and should not be relied upon as protection for the vehicle or passengers. Buyers assume all risk and liability whatsoever resulting from installation and use of ARMORDILLO products. ARMORDILLO assumes no liability for injury, loss, incidental or consequential damages in the event of an accident.

ARMORDILLO guarantees the original purchaser a LIMITED 1 YEAR WARRANTY from date of purchase against manufactured defects in materials, workmanship and finish under normal use. This excludes damage resulting from road hazards, debris, product misuse, improper installation, impairments from accidents, neglect, shipping or product modification. This warranty applies only to new products and is limited to the repair or replacement of ARMORDILLO products. Warranty does not included cost of removal, installation, labor, freight, inconvenience, or consequential damage. Original purchaser must return defective merchandise to the original place of purchase and must provide the proof of purchase.

Bill Of Materials:

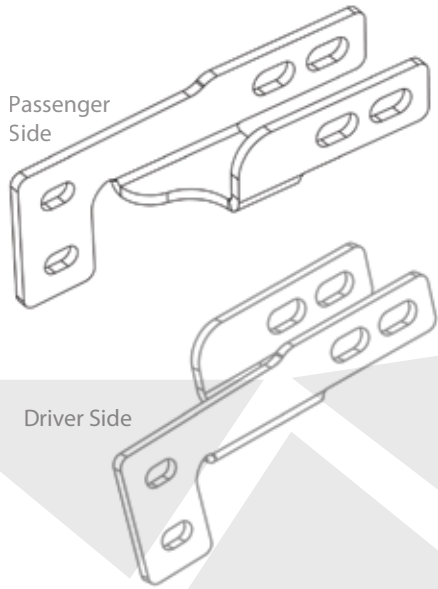

HARDWARE			
QTY	DESCRIPTION	QTY	DESCRIPTION
1	Bull Bar	8	12mm x 24mm OD x 2.5mm Flat Washers
1	Driver Bracket	4	12-1.75mm Nylon Lock Nuts
1	Passenger Bracket	4	10-1.5mm x 30mm Hex Bolts
4	12-1.75mm x 80mm Hex Bolts	8	10mm x 24mm OD x 2.2mm Flat Washers
4	10-1.5mm Nylon Lock Nuts		



LEVEL OF DIFFICULTY: EASY

PRO INSTALL TIME: 20 MIN.

NOVICE INSTALL TIME: 40 MIN.



INSTALLATION TIPS:

- 1) REMOVE CONTENTS FROM BOX. VERIFY ALL PARTS LISTED ARE PRESENT AND FREE OF DAMAGE. READ AND UNDERSTAND ALL INSTRUCTIONS BEFORE ATTEMPTING INSTALLATION.
- 2) CUTTING OF LOWER VALANCE OR TRIM MAYBE REQUIRE, INSTALLATION MAY INTERFERE WITH FRONT SENSORS ON BUMPER.
- 3) TWO PERSON WILL BE REQUIRED WHEN MOUNTING AND ALIGNING BULL BAR
- 4) USING PROPER TOOLS WILL IMPROVE THE QUALITY OF THE INSTALL AND REDUCE THE TIME REQUIRED.
- 5) NEED HELP OR HAVE SOME QUESTIONS CALL US AT (909) 895-4522 OR EMAIL US AT SUPPORT@ARMORDILLOUSA.COM
- 6) REMOVAL OF FRONT LICENSE PLATE IS REQUIRED, RELOCATION OF FRONT LICENSE PLATE IS HIGHLY RECOMMENDED.
- 7) ANTI-SEIZE LUBRICANT IS HIGHLY RECOMMEND TO USED ON ALL STAINLESS STEEL FASTENERS TO PREVENT DAMAGE TO THE THREAD AND GALLING.

TOOL REQUIRED

	SIZE	DESCRIPTION
	3/8"	Ratchet
	19mm	Socket
	19mm	Wrench

PROCEDURE:

REMOVE CONTENTS FROM BOX AND VERIFY ALL PARTS ARE PRESENT. READ INSTRUCTIONS CAREFULLY. CUTTING MAY BE REQUIRED. INSTALLATION MAY INTERFERE WITH FRONT MOUNTED SENSORS.

NOTE: It may be necessary to remove/relocate front license plate and license plate bracket. It is not required, but strongly recommended. If local/state law requires a front license plate, license plate relocation kit is available.

1. Start installation from under the front of the vehicle. Remove the plastic splash guard from below-behind bumper, **(Page 4)**. Determine if the vehicle is equipped with tow hooks. **IMPORTANT:** Tow hooks cannot be reinstalled with the Bull Bar. Also, it may be necessary to temporarily remove the factory skid plate, (if equipped), to access the mounting locations.

Tow Hook equipped vehicles:

a. Remove the driver side tow hook and hardware from the end of the frame channel, **(Page 4)**. Also remove the seal between the opening in the bumper and the tow hook, **(Page 4)**.

b. Repeat to remove the passenger side tow hook.

c. Proceed to **Step 2**.

Vehicles without tow hooks:

a. Cut out the indented area in both sides of the plastic bumper to clear the Brackets as pictured, **(Page 5)**. **IMPORTANT:** Make several small cuts for best fit. **OPTION:** Cut around the Bracket as indicated, **(Page 5)**, or cut along the rectangular cut line molded into the pocket.

2. Select the driver side Mounting Bracket. Insert the Bracket through the opening in the bumper and up to the tow hook mounting holes, **(Page 5)**. Trim the plastic as required Bracket clearance.

3. Line up the (2) holes in the Bracket with the (2) holes in the frame for the tow hook. Select (2) 12mm x 80mm Long Hex Bolts and (2) 12mm Flat Washers, **(Page 5)**. Insert the Bolts with Washers through the Bracket and the (2) holes through the frame, **(page 5)**. Secure with (2) 12mm Flat Washers and (2) 12mm Nylon Lock Nuts. Do not fully tighten hardware at this time.

4. Repeat **Steps 2 & 3** to install the passenger side Mounting Bracket.

5. With assistance, hold the Bull Bar up in position on the outside of the Mounting Brackets. Bolt the Bull Bar to the Brackets with (4) 10mm x 30mm Hex Bolts, (8) 10mm Flat Washers and (4) 10mm Nylon Lock Nuts, **(Page 5)**. Do not tighten hardware at this time.

6. Check the Bull Bar alignment with the vehicle and for clearance between the Bull Bar and the bumper. Adjust as required then fully tighten all hardware at this time.

7. Reinstall the plastic splash guard or skid plate removed in **Step 1**, **(page 4)**.

8. Do periodic inspections to the installation to make sure that all hardware is secure and tight. **To protect your investment**, wax this product after installing. Regular waxing is recommended to add a protective layer over the finish. Do not use any type of polish or wax that may contain abrasives that could damage the finish. **For stainless steel:** Aluminum polish may be used to polish small scratches and scuffs on the finish. Mild soap may be used also to clean the Bull Bar. **For gloss black finishes:** Mild soap may be used to clean the Bull Bar.

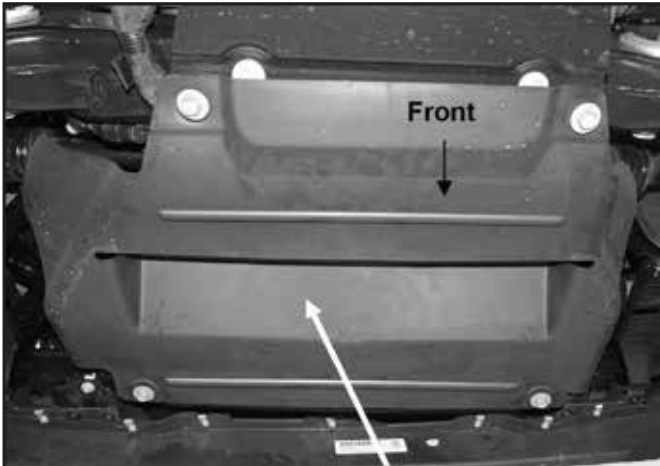

plastic splash guard



Remove Tow Hook

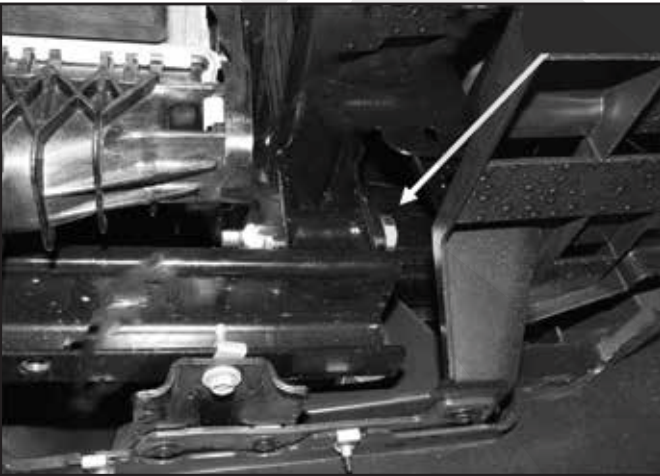

Tow Hook Bolt Location On Back Side



Bracket & Seal Removed



Vehicle With Out Tow Hooks

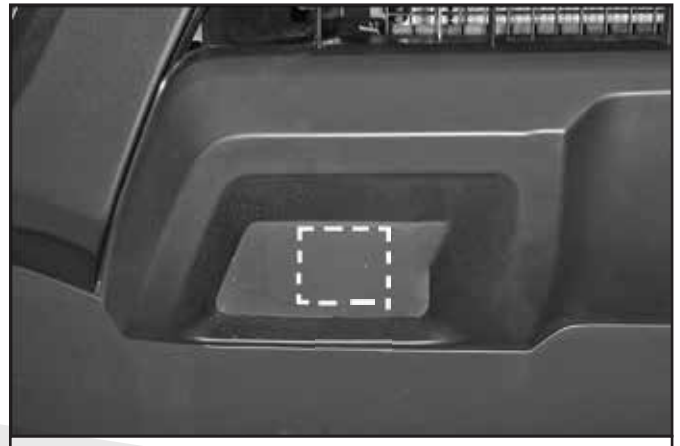

Cut Out Area



Driver Side Mounting Bracket Location

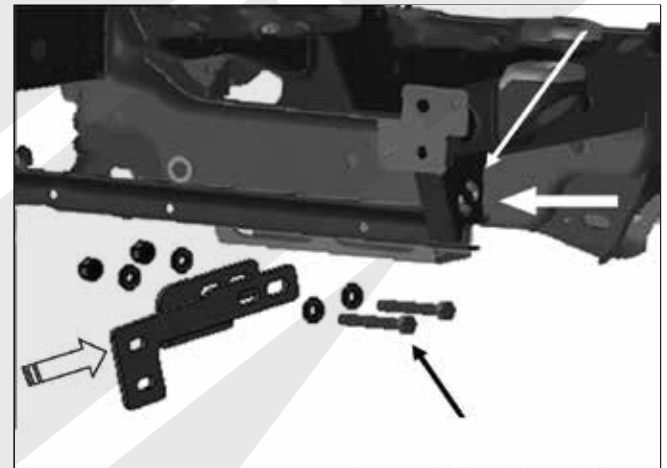

Driver Side Bracket (2) 12mm x 80mm Long Hex Bolts and (2) 12mm Flat Washers (2) 12-1.75mm Nylon Lock Nuts

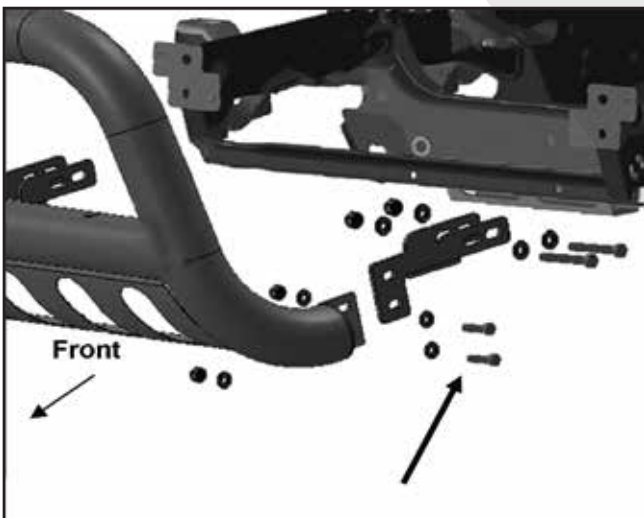

From Bull Bar To Bracket Use (4) 10mm x 30mm Hex Bolts, (8) 10mm Flat Washers and (4) 10mm Nylon Lock Nuts



Finished