



## AR Series Bull Bar

### FITMENTS 2007-2009 Jeep Wrangler

**STOP - Verify part and application is correct before proceeding.  
If missing part or damage item please customer service directly.**

**Call us at (909) 895-4522 Monday-Friday 9am-6pm PST  
Email us at [SUPPORT@ARMORDILLOUSA.COM](mailto:SUPPORT@ARMORDILLOUSA.COM)**

#### **ARMORDILLO RECOMMENDS PROFESSIONAL INSTALLATION ON ALL THEIR PRODUCTS**

**WARNING:** When working on ,under or around vehicle exercise caution. If working without a lift check vehicle owners manual for correct jacking points. Always wear safety glasses and ensure a safe working area. Serious injury or death could occur if safety measures are not followed.

#### **PERIODICALLY CHECK TO ENSURE ALL FASTENERS ARE TIGHT AND ALL STRUCTURAL COMPONENTS ARE SOUND CARE**

To protect your investment, wax this product after installing. Regular waxing is recommended to add a protective layer over the finish. Do not use any type of polish or wax that may contain abrasives, that could damage the finish.

For stainless steel: Aluminum polish may be used to polish small scratches and scuffs on the finish.  
Mild soap may be used to clean bull guard.

For color finishes: Regular waxing is recommended to add a protective layer over the finish.  
Mild soap may be used to clean the bull guard.

*ARMORDILLO products are designed as decorative accessories and should not be relied upon as protection for the vehicle or passengers. Buyers assume all risk and liability whatsoever resulting from installation and use of ARMORDILLO products. ARMORDILLO assumes no liability for injury, loss, incidental or consequential damages in the event of an accident.*

*ARMORDILLO guarantees the original purchaser a LIMITED 1 YEAR WARRANTY from date of purchase against manufactured defects in materials, workmanship and finish under normal use. This excludes damage resulting from road hazards, debris, product misuse, improper installation, impairments from accidents, neglect, shipping or product modification. This warranty applies only to new products and is limited to the repair or replacement of ARMORDILLO products. Warranty does not included cost of removal, installation, labor, freight, inconvenience, or consequential damage. Original purchaser must return defective merchandise to the original place of purchase and must provide the proof of purchase.*

# Bill Of Materials:



HARDWARE			
QTY	DESCRIPTION	QTY	DESCRIPTION
1	Bull Bar	2	1/2" Lock Washer
1	Driver Bracket	2	M12 Hex Bolt
1	Passenger Bracket	8	M12 Washer
2	Support Bracket	6	M12 Lock Washer
2	M12 T-bolt	6	M12 Nut
2	M12 Bolt Plate	2	M10 Washer
2	M10 Bolt Plate	2	M10 Lock Washer
2	1/2" Hex Bolt	2	M10 Nut
2	1/2" Washer		

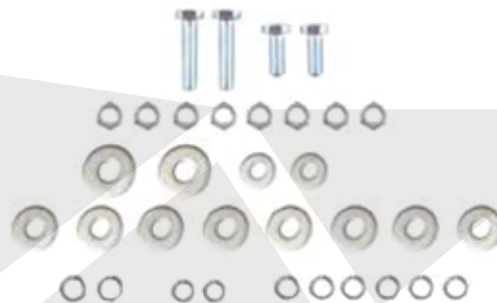

**LEVEL OF DIFFICULTY: EASY**

**PRO INSTALL TIME: 20 MIN.**

**NOVICE INSTALL TIME: 40 MIN.**



### INSTALLATION TIPS:

- 1) REMOVE CONTENTS FROM BOX, VERIFY ALL PARTS LISTED ARE PRESENT AND FREE OF DAMAGE. READ AND UNDERSTAND ALL INSTRUCTIONS BEFORE ATTEMPTING INSTALLATION.
- 2) CUTTING OF LOWER VALANCE OR TRIM MAYBE REQUIRE, INSTALLATION MAY INTERFERE WITH FRONT SENSORS ON BUMPER.
- 3) TWO PERSON WILL BE REQUIRED WHEN MOUNTING AND ALIGNING BULL BAR
- 4) USING PROPER TOOLS WILL IMPROVE THE QUALITY OF THE INSTALL AND REDUCE THE TIME REQUIRED.
- 5) NEED HELP OR HAVE SOME QUESTIONS CALL US AT (909) 895-4522 OR EMAIL US AT [SUPPORT@ARMORDILLOUSA.COM](mailto:SUPPORT@ARMORDILLOUSA.COM)
- 6) REMOVAL OF FRONT LICENSE PLATE IS REQUIRED, RELOCATION OF FRONT LICENSE PLATE IS HIGHLY RECOMMENDED.
- 7) ANTI-SEIZE LUBRICANT IS HIGHLY RECOMMEND TO USED ON ALL STAINLESS STEEL FASTENERS TO PREVENT DAMAGE TO THE THREAD AND GALLING.

### TOOL REQUIRED

	SIZE	DESCRIPTION
	3/8"	Ratchet
	13mm	Socket
	13mm	Wrench

1) Remove the plastic splash guard from under the front bumper and place it on a clean, stable working surface.

2) Starting on the driver side, insert (1) M12 T-Bolt into the opening in the end of the crossmember and down through the outer hole. Hang the driver side Mounting Bracket from the T-Bolt with (1) M12 Washer, (1) M12 Lock Washer and (1) M12 Nut. Next, insert the M10 Bolt Plate into the same opening in the cross member and out through the back and through the Mounting Bracket. Secure the Bolt Plate with (1) M10 Washer, (1) M10 Lock Washer and (1) M10 Nut, (Figure 1). Snug but do not tighten the hardware at this time.

3) Insert (1) M12 Bolt Plate into the opening in the welded mount on the end of the crossmember. Line up the Bolt Plate with the middle hole in the vertical mount, (Figure 2). Hang the square end of the Support Bracket from the M12 Bolt Plate and secure it with (1) M12 Flat Washer, (1) M12 Lock Washer and (1) M12 Nut, (Figure 3). Leave loose at this time.

4) Repeat steps 1-3 for passenger side bracket installation. Position the splash guard back up to the vehicle and attach with two clips at the front-top outer mounting positions only. Pull the splash guard back to the Mounting Brackets to estimate the Passenger/Right Mounting Bracket Driver/Left Mounting Bracket (2) M12 Bolt Plates (2) M10 Bolt Plates (2) M12 T-Bolts (2) Support Brackets amount of cutting required to clear the Brackets and Bull Bar. Mark the location of the Mounting Brackets onto the back of the splash guard. Determine the location for the slot for the Support Bracket, (Figure 4). NOTE: To maintain the integrity of the plastic Splash Guard, remove only enough material to clear the Bull Bar and Brackets. Make small cuts and check the fit several times before final installation. Reinstall the splash guard using the factory hardware.

5) With help, position the Bull Bar up to the Mounting Brackets. Use the included (2) 1/2" Hex Bolts, (2) 1/2" Washers and 1/2" Lock Washers to attach the Bull Bar to the Mounting brackets, (Figure 5). Snug but do not tighten at this time.

6) Align the Bull Bar properly and tighten all hardware. Do periodic inspections to the installation to make sure is secure and tight.

12mm x 30mm T-Bolt

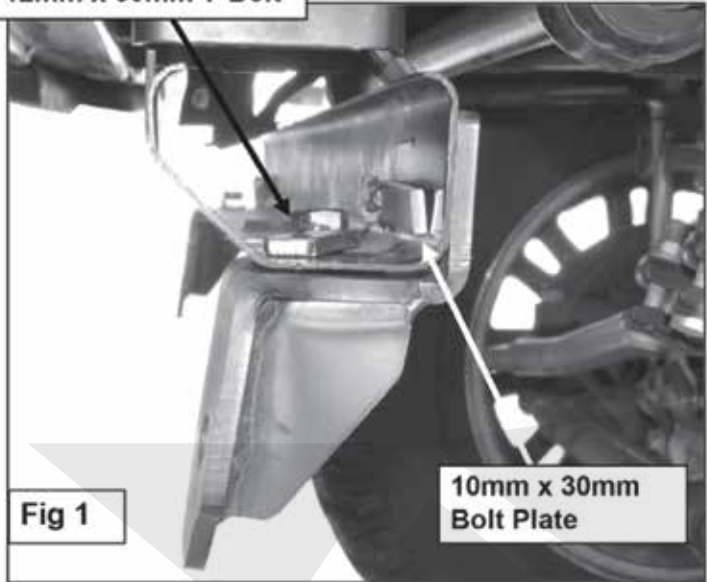

Fig 1

10mm x 30mm Bolt Plate

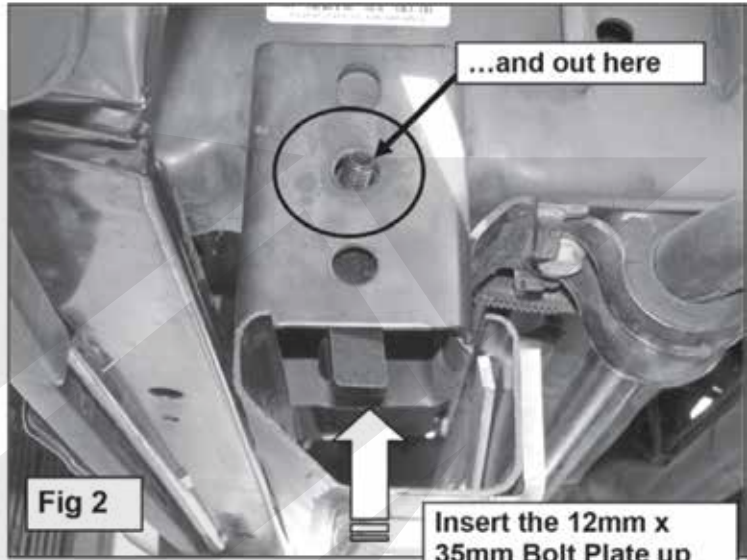
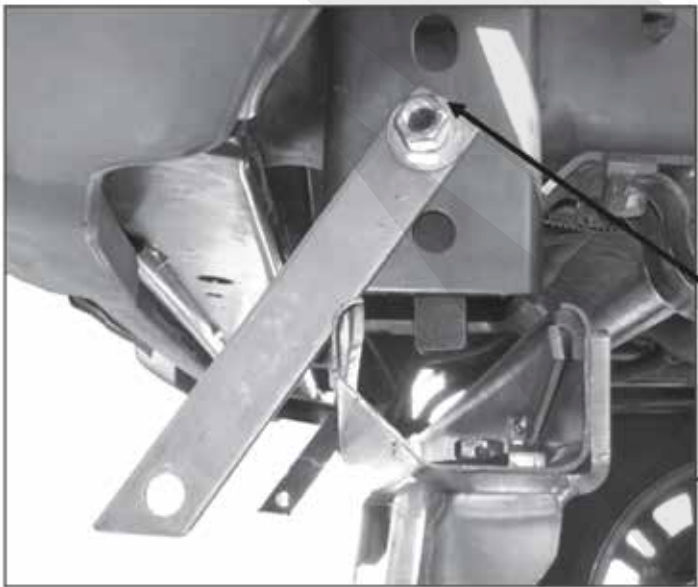

Fig 2

...and out here

Insert the 12mm x 35mm Bolt Plate up through here...



12mm x 35mm Bolt Plates  
 12mm Lock Washers  
 12mm Flat Washers  
 12mm Hex Nuts

← Front

