

RS Running Boards
2007-2018 Chevy Silverado 1500 / GMC Sierra 1500 - Crew Cab
2007-2019 Chevy Silverado 2500/3500 / GMC Sierra 2500/3500 - Crew Cab



ARMORDILLO Products are designed as decorative accessories and should not be relied upon as protection for the vehicle or passengers. Buyers assume all risk and liability whatsoever resulting from installation and use of products. We assume no liability for injury, loss, incidental or consequential damages in the event of an accident.

ARMORDILLO guarantees the original purchaser a LIMITED 3-YEAR WARRANTY from date of purchase against manufactured defects in materials, workmanship and finish under normal use. This excludes damage resulting from road hazards, debris, product misuse, improper installation, impairments from accidents, neglect, shipping or product modification. This warranty applies only to new products and is limited to the repair or replacement products. Warranty does not include cost of removal, installation, labor, freight, inconvenience, or consequential damage. Original purchaser must return defective merchandise to the original place of purchase and must provide the proof of purchase.

WARNING: When working on, under or around vehicle exercise caution. If working without a lift check vehicle owners manual for correct jacking points. Always wear safety glasses and ensure a safe working area. Serious injury or death could occur if safety measures are not followed.

ARMORDILLO RECOMMENDS PROFESSIONAL INSTALLATION ON ALL THEIR PRODUCTS STOP - Verify part and application is correct before proceeding. If missing part or damage item please contact customer service directly via message system on the site you bought the item from.

Call us at (909)895-4522 Monday-Friday 9am-6pm PST
Email us At SUPPORT@ARMORDILLOUSA.COM

RS Running Boards
2007-2018 Chevy Silverado 1500 / GMC Sierra 1500 - Crew Cab
2007-2019 Chevy Silverado 2500/3500 / GMC Sierra 2500/3500 - Crew Cab

PARTS LIST:

1	Driver/Left Running Board	1	8mm Bolt Plate
1	Passenger/Right Running Board	1	8mm x 40mm Hex Bolt
4	Driver/Left Mounting Brackets	16	8mm x 25mm Hex Bolts
3	Passenger/Right Mounting Brackets	16	8mm Lock Washers
1	Passenger/Right Front Upper Mounting Bracket	17	8mm x 24mm OD x 2mm Flat Washers
1	Passenger/Right Front Lower Mounting Bracket	1	8mm Nylon Lock Nut
16	10mm x 35mm Hex Bolts	15	8mm Clip Nuts
32	10mm x 27mm OD x 3mm Flat Washers	1	4mm Hex Wrench
16	10mm Nylon Lock Nuts		

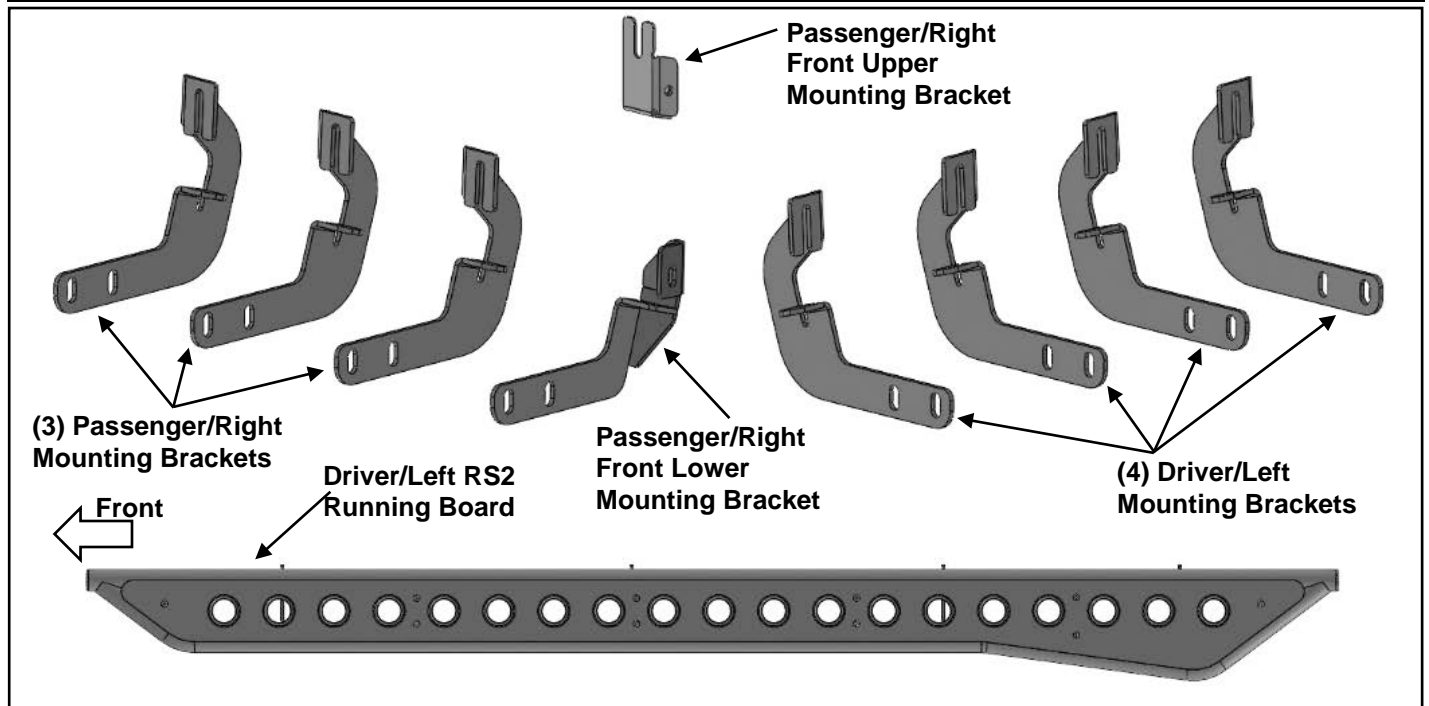

PROCEDURE:

REMOVE CONTENTS FROM BOX. VERIFY ALL PARTS ARE PRESENT. READ INSTRUCTIONS CAREFULLY BEFORE STARTING INSTALLATION. ON MODELS WITH DEF TANK, SELECT A FLAT, LEVEL AREA FOR INSTALLATION. MAY REQUIRE CUTTING.

1. Start the installation under the Driver/Left side of the vehicle. Locate the 5 tabs along the bottom edge of the body, (pinch weld). Mounting Brackets will bolt to the 1st, 3rd, 4th and 5th mounting tabs, **(Figure 1)**. Directly above each tab is a top mounting location on the side of the rocker panel. Hold a Bracket up in place to help determine the mounting holes to use.
2. Determine the correct procedure for your model year and each Bracket location.

Bottom mounting location on the edge of the pinch weld.

Flat tab on pinch weld with factory installed weld nut:

Thread hex bolt into weld nut from the backside-down to clear paint from threads.

Flat tab on pinch weld with hole:

Select (1) 8mm Clip Nut. Slide the Clip Nut over the tab with the nut facing up behind the tab, **(Figures 2 & 3)**. Line up threaded nut with hole in the tab. Repeat for each mounting location.

Locate top mounting location on the back side of the rocker panel.

Models with factory installed threaded insert in rocker panel:

Thread 8mm Hex Bolt into threaded insert to clear paint as required, **(Figures 2 & 3)**.

RS Running Boards
2007-2018 Chevy Silverado 1500 / GMC Sierra 1500 - Crew Cab
2007-2019 Chevy Silverado 2500/3500 / GMC Sierra 2500/3500 - Crew Cab

Large and small hole in side of body panel:

Remove the rubber plug from the larger hole, **(Figure 4)**. Select (1) 8mm Clip Nut. Slide the Clip Nut into the larger hole. Line up the threaded nut with the smaller hole.

3. Select (1) Driver/Left Mounting Bracket. Attach the Mounting Bracket to the Clip Nuts and/or the factory threaded holes with (2) 8mm Hex Bolts, (2) 8mm Lock Washers and (2) 8mm Flat Washers, **(Figure 5)**. Do not tighten hardware.
4. Repeat **Steps 1—3** to attach (3) Driver/Left Mounting Brackets to the Driver/Left side.
5. Select the Driver/Left RS2 Running Board. Attach the Running Board to the rear faces of the (4) Mounting Brackets with (8) 10mm Hex Nuts, (16) 10mm Flat Washers and (8) 10mm Nylon Lock Nuts, **(Figure 6)**. Do not tighten hardware
6. Move to the Passenger/Right side of the vehicle. Determine if the vehicle is equipped with a plastic diesel exhaust fluid (DEF) tank, **(Figures 7 & 8)**.

Models without DEF tank, skip to Step 7.

Models with DEF tank: The tank sits close to the side of the body. With specialized tools, the Passenger/Right Front Upper and Lower Mounting Brackets can be installed but room is very limited. Determine model year of vehicle before proceeding.

Up to 2016 models:

It may be easier to drop the tank down to access the inner side of the body panel for upper bracket installation. Tank will not need to be removed, only dropped down for access to mounting location.

IMPORTANT: If tank is full, it will be very heavy and assistance is highly recommended to avoid injury or damage to the vehicle or the tank. It is recommended that installation is performed when the DEF tank is low on fluid before dropping the tank.

- a. On models with plastic lower tray under the tank, remove the (3) hex bolts attaching the tray to the frame, **(Figure 7)**, and remove the tray.
- b. Release the tank filler hose. Release the plug for the sending unit on the top of the tank.
- c. Support the tank with a floor jack. Place a smooth flat surface, (wooden block for example), between the floor jack and the tank to avoid damaging the plastic tank. Do not push up on the tank; only support the weight of the tank with the jack.
- d. Remove the (2) bolts securing the tank straps to the vehicle, **(Figure 8)**. Tilt the straps to release from the brackets. Slowly lower the tank until the top of the tank is almost visible. Use blocks or stands to support the tank while installing the Front Upper and Lower Brackets.
- e. Proceed to **Step 7**.

On 2017 models and on:

- a. If necessary, remove the (4) hex bolts attaching plastic cover to DEF tank, **(Figure 9)** and remove plastic cover for better access. **NOTE:** On 2017-on 2500/3500 models, only remove plastic cover from DEF tank. **Do not lower DEF tank** and proceed to **Step 7**.
7. Locate the first tab on the edge of the pinch weld. Select the Upper Bracket, **(Figure 10)**. Repeat **Steps 2 & 3** to attach the Passenger/Right Front Upper Mounting Bracket to the side of the rocker panel, **(Figure 11)**. Do not tighten hardware.
8. Line up the hole in the bottom of the Upper Bracket with the hole in the tab on the pinch weld.
 - a. **Models with a weld-nut:** Slide the Bracket over the weld-nut, **(Figure 11)**. Attach the Lower Mounting Bracket to the bottom of the pinch weld and weld-nut with (1) 8mm Hex Bolt, (1) 8mm Lock Washer and (1) 8mm Flat Washer, **(Figure 14)**. Do not tighten hardware.
 - b. **Models with flat tab and hole:** Insert the 8mm Bolt Plate down through the hole in the Upper Mounting Bracket and mounting tab. Attach the Lower Bracket to the bottom of the body and Bolt Plate with (1) 8mm Flat Washer and (1) 8mm Nylon Lock Nut. Leave loose at this time, **(Figures 12, 13 & 15)**. Do not tighten hardware at this time.
9. Line up the side tab on the Lower Bracket with the threaded hole in the side of the Upper Bracket. Attach the Lower Bracket to the Upper Bracket with (1) 8mm Hex Bolt, (1) 8mm Lock Washer and (1) 8mm Flat Washer, **(Figures 14 & 15)**. Leave loose at this time.
10. Repeat **Steps 1—3** to attach the remaining (3) Mounting Brackets to the Passenger/Right rocker panel.

RS Running Boards
2007-2018 Chevy Silverado 1500 / GMC Sierra 1500 - Crew Cab
2007-2019 Chevy Silverado 2500/3500 / GMC Sierra 2500/3500 - Crew Cab

11. **For 2017 2500/3500 DEF tank models:** Locate the 2nd mounting location along the bottom edge of the body, (pinch weld), **(Figure 1)**. Hold the DEF cover in place and mark the 2nd Bracket location onto the cover, **(Figure 16)**. Use a sharp knife or hacksaw blade to carefully cut a slot in the plastic cover to clear the 2nd Bracket, **(Figure 17)**. Remove as little plastic as possible.
12. Repeat **Steps 5 & 6** to attach the Passenger/Right RS2 Running Board.
13. Once the Running Board has been attached and all hardware fully tightened, reinstall the DEF tank and cover, if equipped, as described in **Step 8**.
14. **(OPTIONAL)** If treads on the stepping platform are desired, remove the platforms from both Running Boards and reattach them to the opposite sides, **(Figure 17)**.
15. Do periodic inspections to the installation to make sure that all hardware is secure and tight.

To protect your investment, Do not use any type of polish or wax that may contain abrasives that could damage the finish. Mild soap may be used also to clean the Running Boards.

Driver/Left Side Installation Pictured

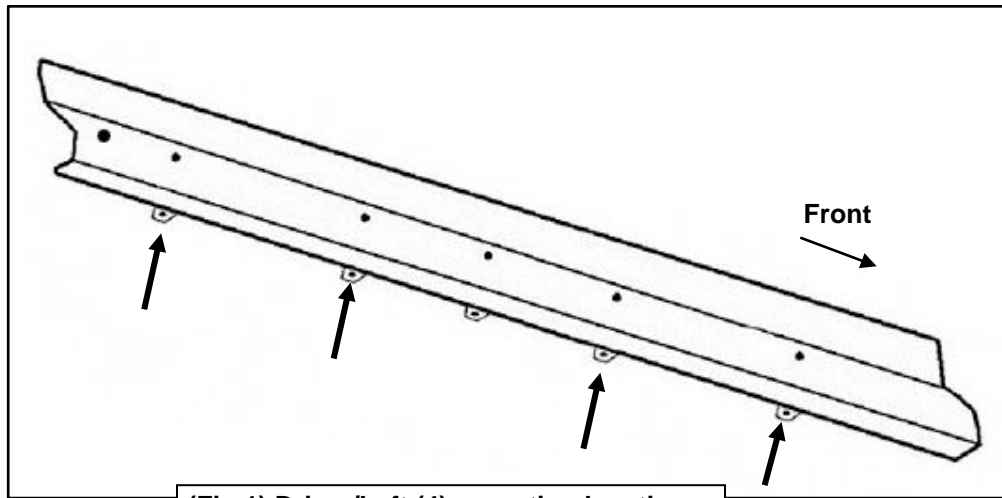

(Fig 1) Driver/Left (4) mounting locations

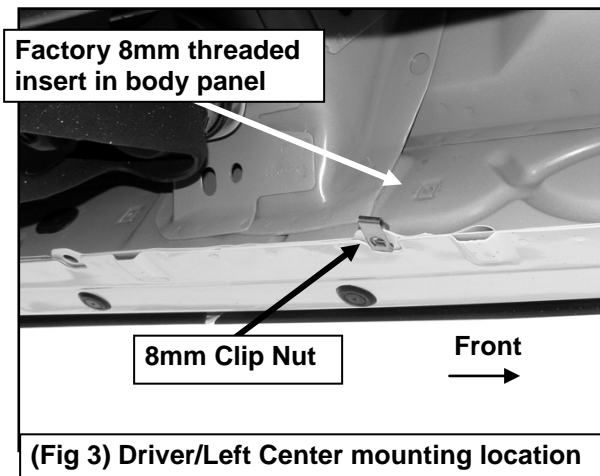

(Fig 3) Driver/Left Center mounting location

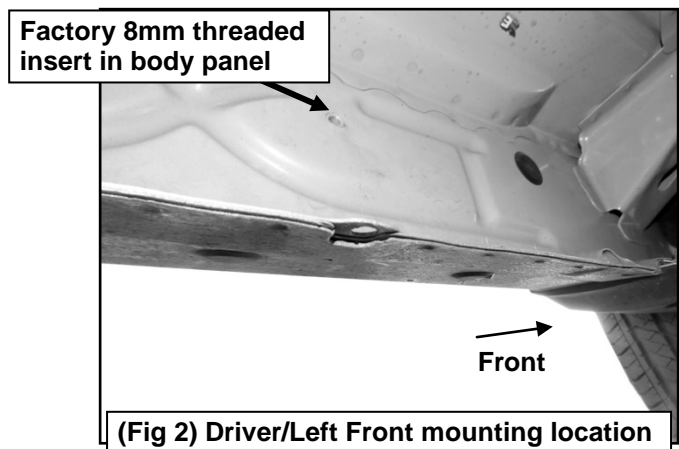

(Fig 2) Driver/Left Front mounting location

RS Running Boards
2007-2018 Chevy Silverado 1500 / GMC Sierra 1500 - Crew Cab
2007-2019 Chevy Silverado 2500/3500 / GMC Sierra 2500/3500 - Crew Cab

Driver/Left Side Installation Pictured

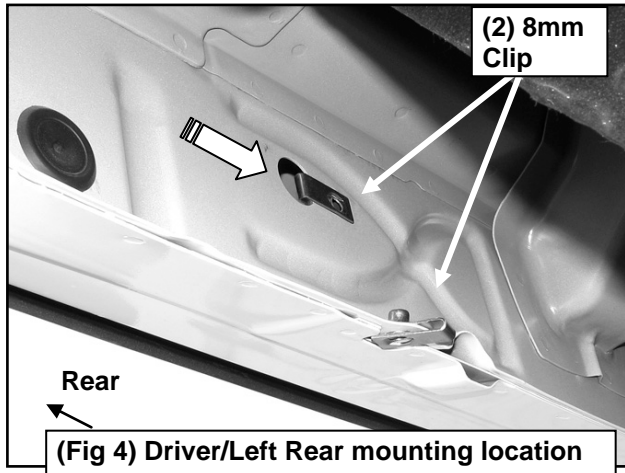

- (2) 8mm x 25mm Hex Bolts
- (2) 8mm Lock Washers
- (2) 8mm Flat Washers
- (2) 8mm Clip Nuts

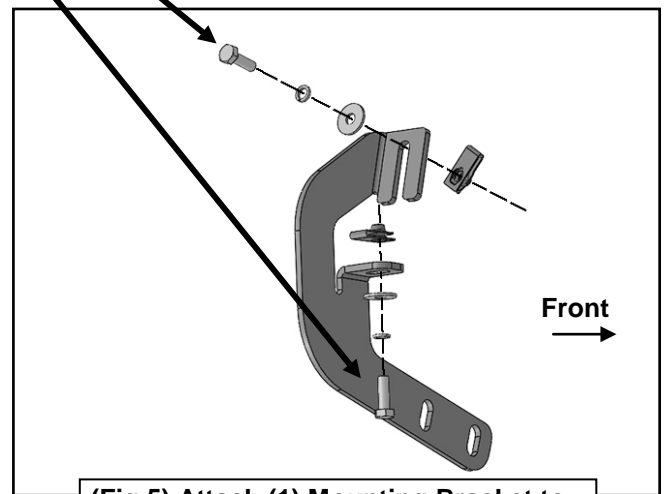

- (2) 10mm Hex Bolts
- (4) 10mm Lock Washers
- (2) 10mm Flat Washers

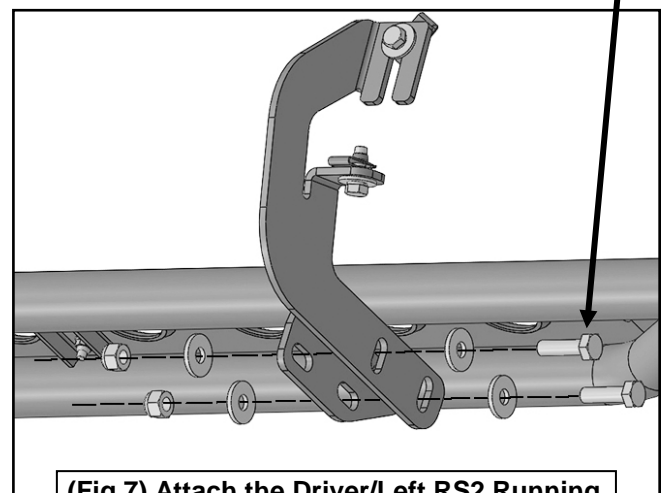

Passenger/Right Front Installation Pictured

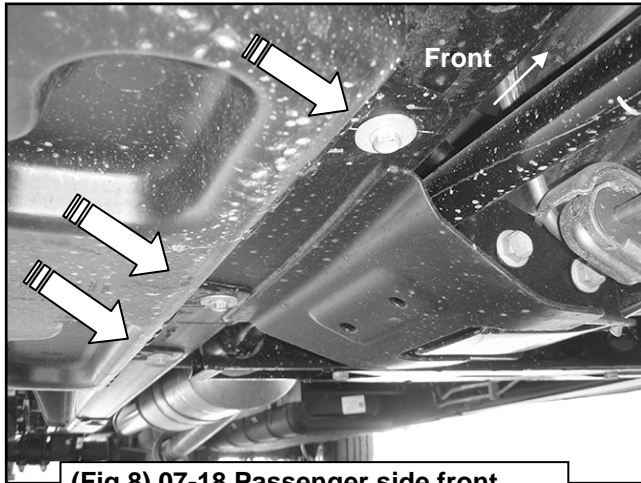

(Fig 8) 07-18 Passenger side front pictured with DEF tank cover. Remove (3) hex bolts to remove cover

Remove (2) factory bolts to remove tank straps

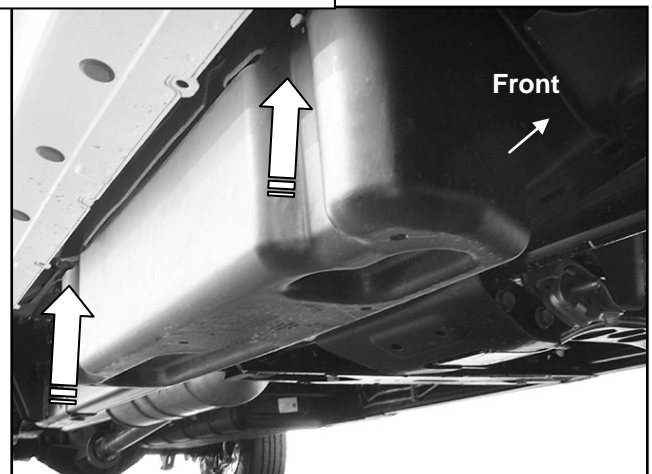

(Fig 9) 07-18 Passenger side DEF tank and cover

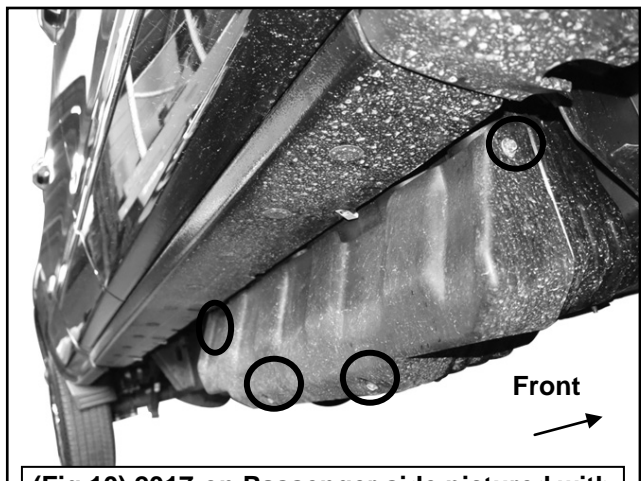

(Fig 10) 2017-on Passenger side pictured with DEF plastic tank cover. If needed, remove (4) hex bolts to remove plastic cover.

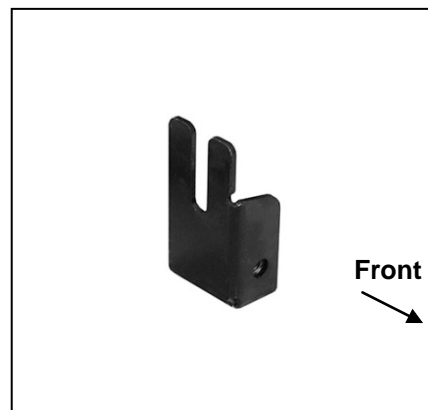

(Fig 11) Passenger/Right Front Upper Bracket (all models)

RS Running Boards
2007-2018 Chevy Silverado 1500 / GMC Sierra 1500 - Crew Cab
2007-2019 Chevy Silverado 2500/3500 / GMC Sierra 2500/3500 - Crew Cab

Passenger/right Front Installation Pictured

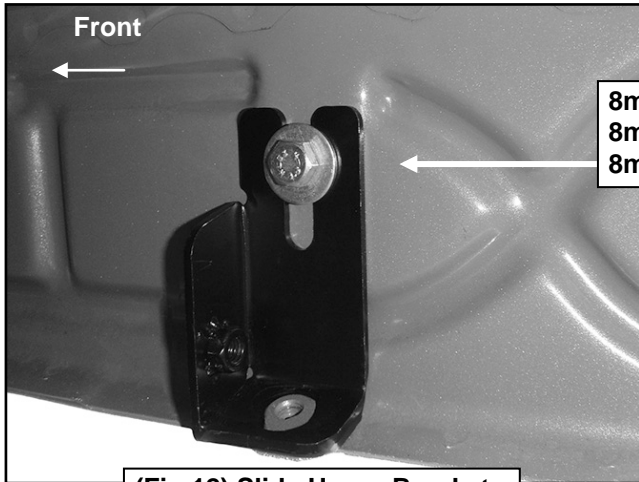

8mm x 25mm Hex Bolt
8mm Lock Washer
8mm Flat Washer

(Fig 12) Slide Upper Bracket over weld nut if equipped



(Fig 13) 8mm

On models with flat tab, insert 8mm Bolt Plate (Fig 16) down through Upper Bracket and mounting tab

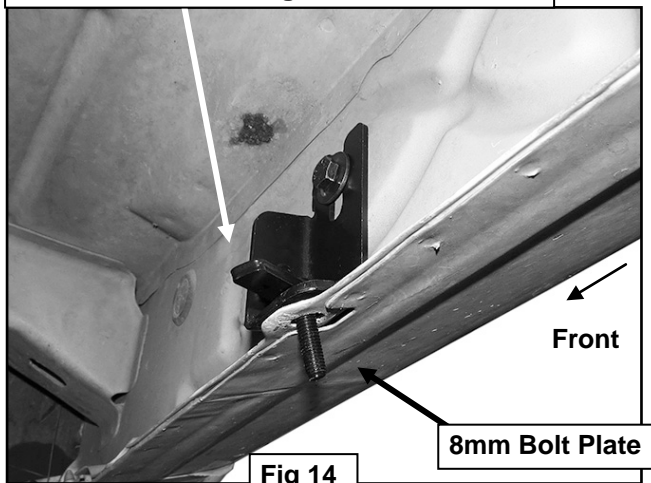
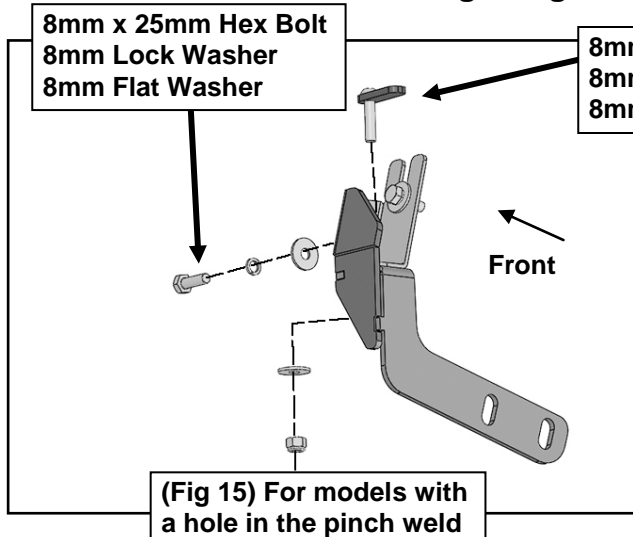

Fig 14

8mm Bolt Plate

RS Running Boards
2007-2018 Chevy Silverado 1500 / GMC Sierra 1500 - Crew Cab
2007-2019 Chevy Silverado 2500/3500 / GMC Sierra 2500/3500 - Crew Cab

Passenger/Right Front Installation Pictured



(Fig 15) For models with a hole in the pinch weld

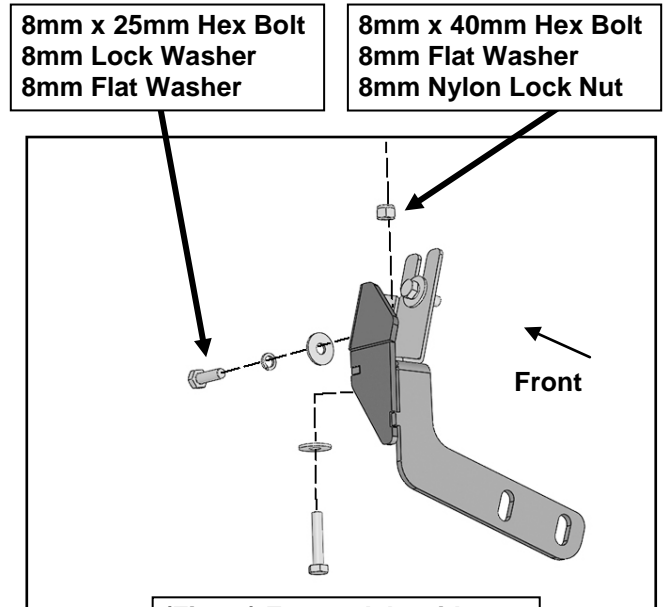

(Fig 17) For models with welded nut in the pinch weld

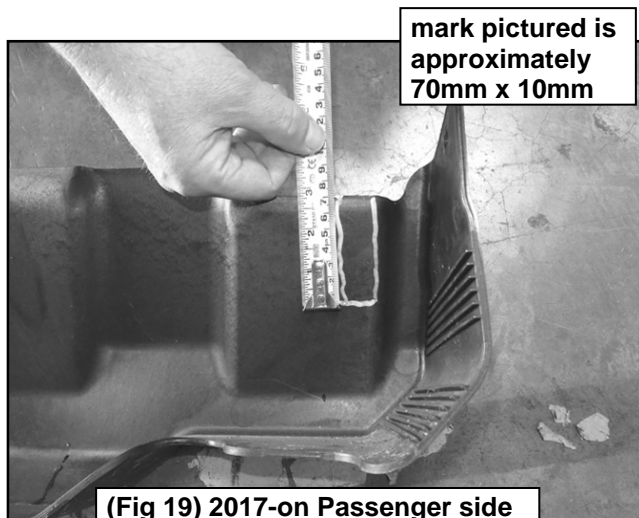

(Fig 19) 2017-on Passenger side DEF cover marked for trimming



(Fig 20) 2017-on Passenger DEF cut for example only

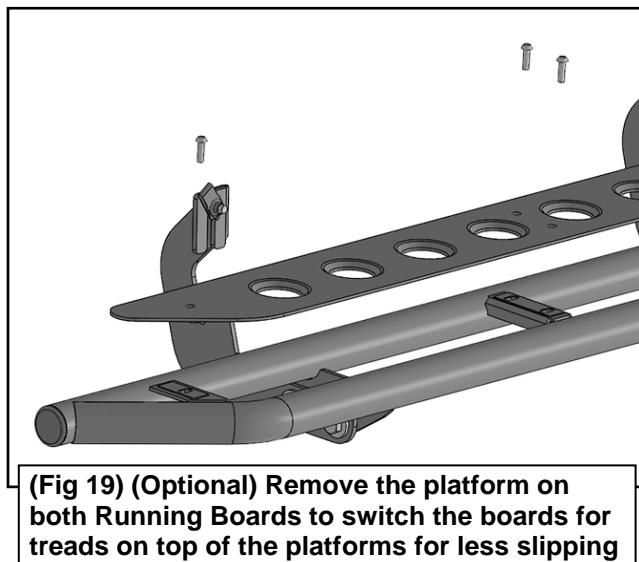

(Fig 19) (Optional) Remove the platform on both Running Boards to switch the boards for treads on top of the platforms for less slipping