



DESTROYER  
**REAR**  
BUMPER  
+ **TIRE**  
CARRIER

**STEP 1:**  
GATHER YOUR  
TOOLS  
AND LAY OUT YOUR  
PARTS...



**Tools Required:**

- 16mm socket
- 3/4" socket
- 1/4" socket
- ratchet
- ratchet Extension
- 3/4" wrench
- tape measure
- floor jack or car jack

**Hardware Provided:**

- Eight (#8 Size) screws
- Eight 1/2"(13) x 4" Hex Bolts
- One 1" spindle Hex nut/washer

- Ten 1/2"(13) Hex Nuts
- Two 1/2"(13) x 4.5" Hex Bolts
- Twenty Two 1/2" Washers
- Two bearings
- One Seal

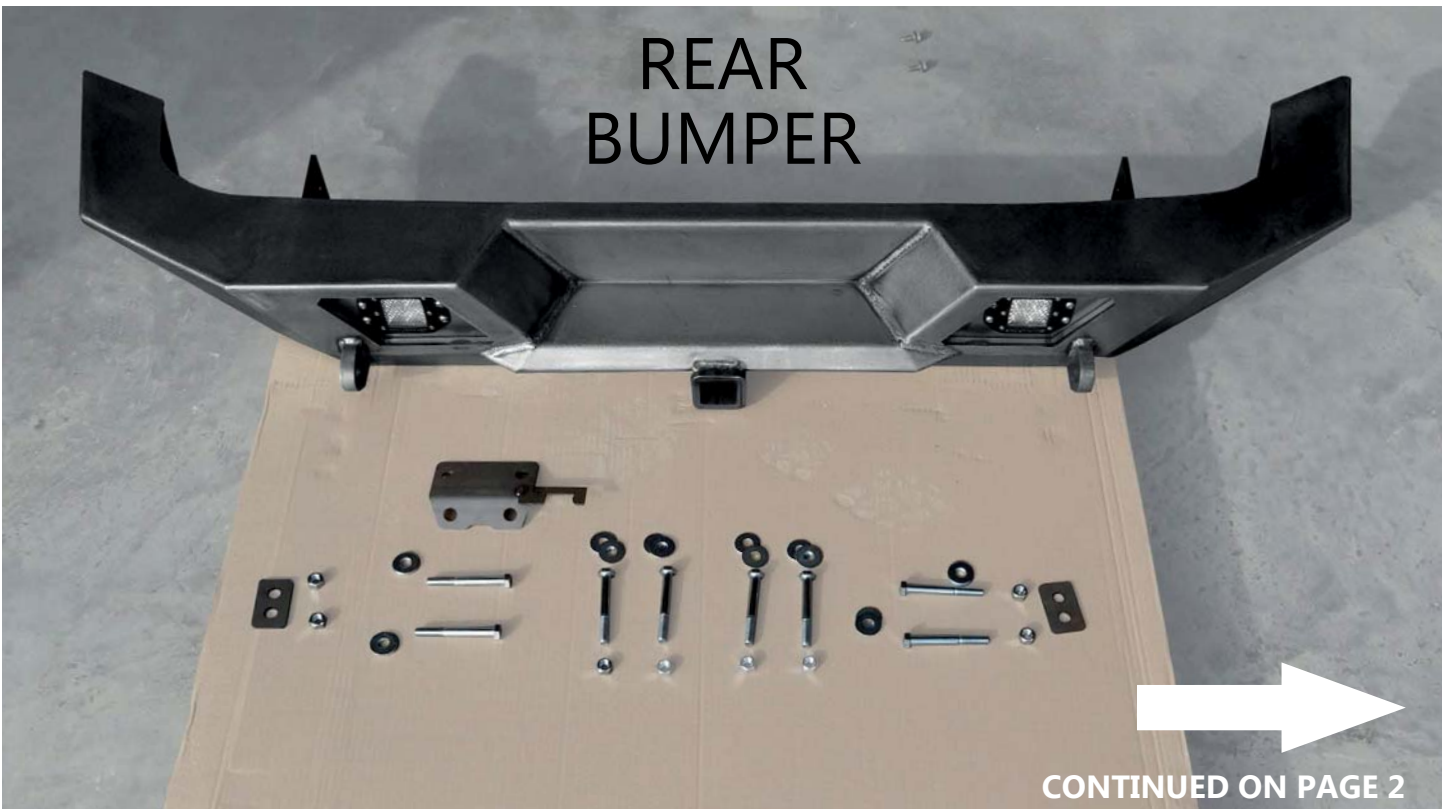

CONTINUED ON PAGE 2

# BUMPER + TIRE CARRIER KIT CONTENTS

## Hand Tools Required:

- 5/16" socket
- 7/16" socket
- 5/8" wrench
- 11/16" wrench
- 3/4" wrench
- 1 1/2 socket\*\*
  - ratchet
- ratchet Extension
  - 5/16" wrench
  - 7/16" wrench
- drill with 5/8" drill bit
  - grease

## Hardware Provided:

<b>7/16(20)</b> <ul style="list-style-type: none"><li>- Eight Nuts</li><li>- Eight Bolts (1" long)</li><li>- Sixteen Washers</li></ul>	<b>5/16(24)</b> <ul style="list-style-type: none"><li>- Four Nuts</li><li>- Four Bolts (1")</li><li>- Eight Washers</li></ul>	<b>1(14)"</b> <ul style="list-style-type: none"><li>- Single hex nut for carrier spindle</li><li>- Single washer</li></ul>	<b>1/2(20)"</b> <ul style="list-style-type: none"><li>- Two washer nuts for the quick latch</li></ul>
<b>LM48548</b> <ul style="list-style-type: none"><li>- Top tapered bearing, faces down</li></ul>	<b>LM29749</b> <ul style="list-style-type: none"><li>- Bottom tapered bearing, faces up</li></ul>	<b>Seal 450068</b> <ul style="list-style-type: none"><li>- Timken spindle seal</li></ul>	

\*\*required, purchase at local auto store

## TIRE CARRIER

### 5/16(24)

- Four Nuts
- Four Bolts (1")
- Eight Washers

### 7/16(20)

- Eight Nuts
- Eight Bolts (1" long)
- Sixteen Washers

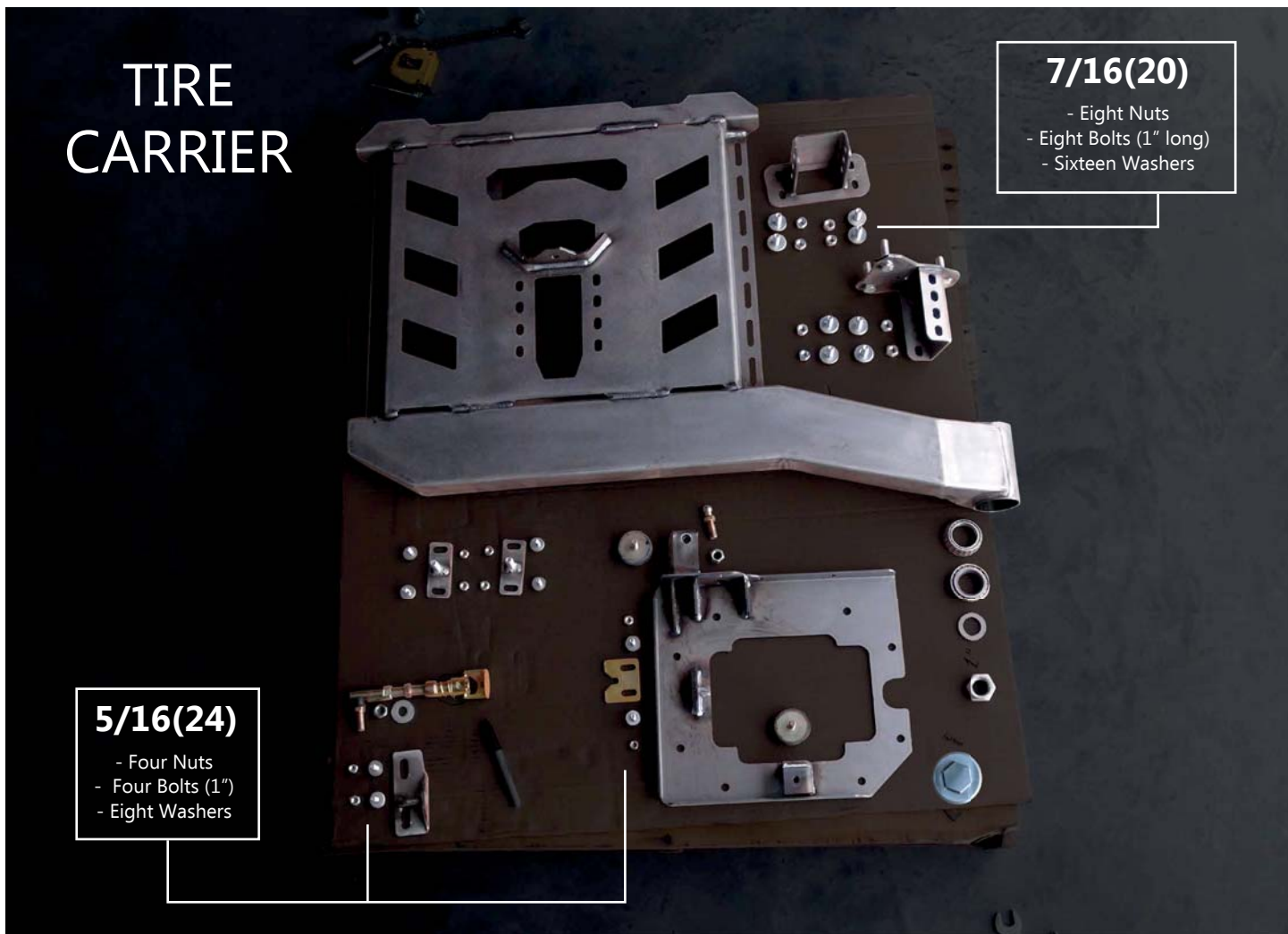

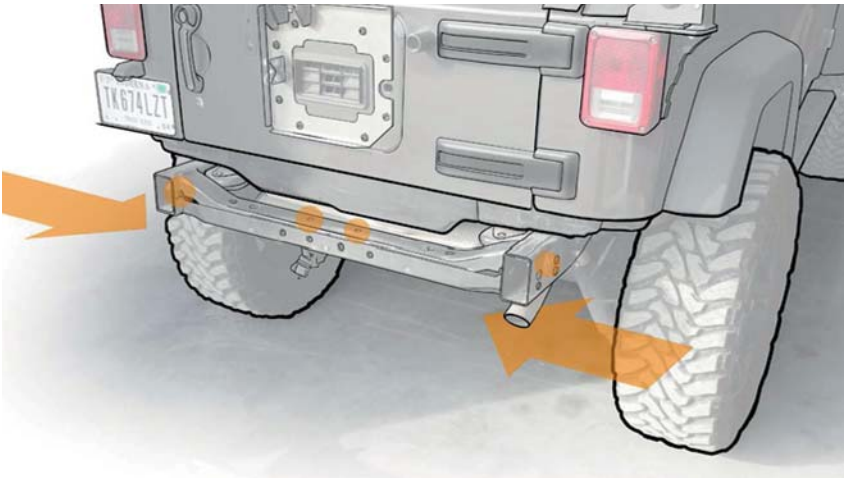

## **STEP 2 :**

Before beginning the installation, there will be 4 locations (shown next) that require drilling through the cross members, two in the middle and one on each side.

USE A 5/8" DRILL BIT FOR THESE.

## **STEP 3 :**

Each side of the frame will have a hole (shown here) that will need to be marked and drilled with a 5/8" drill bit.

This hole can be drilled with the bumper on the vehicle.

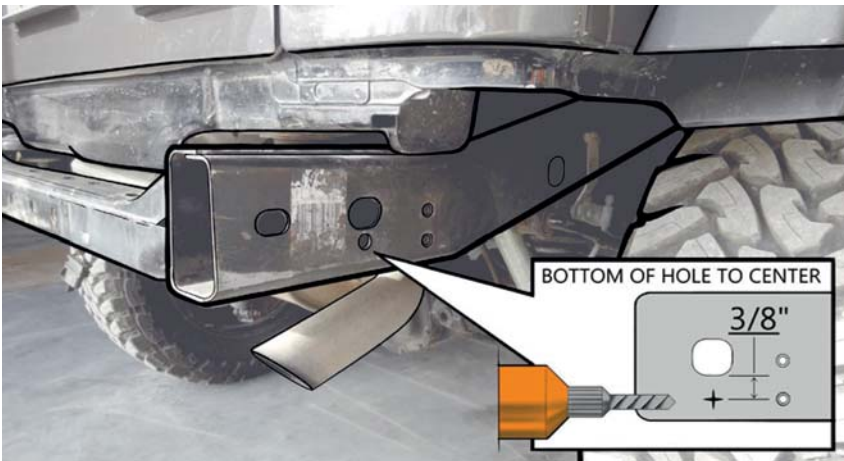

## **STEP 4 :**

After attaching the lights, place the bezel into the frame and attach with the provided #8 self-tapping screws.

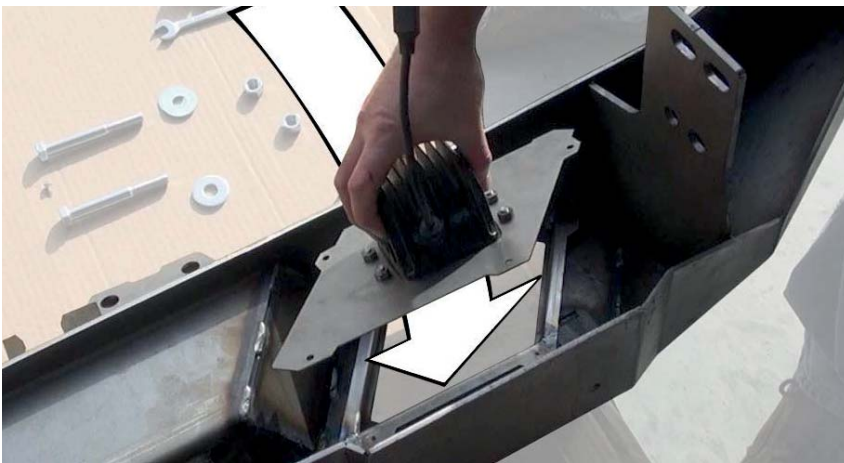

## **STEP 5 :**

Carefully pick up the bumper and slowly center it, then move towards the Jeep.

Take care to avoid damaging the body with the bumper corners.



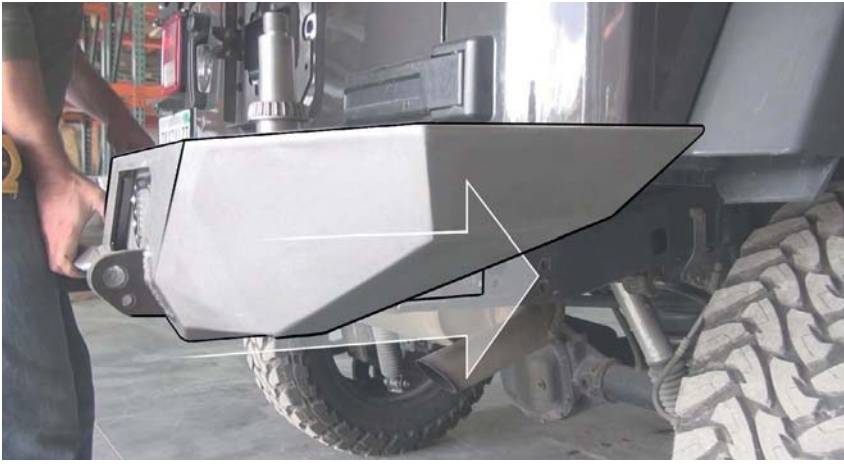

## **STEP 6 :**

Slide the bumper forward onto the frame once the body of the bumper is aligned with the body of the vehicle.



## **STEP 7 :**

Do not let go of the bumper, as it may fall unsupported. While keeping pressure on the bumper, check that the two stock holes (circled) are lining up with the slotted holes in the bumper.

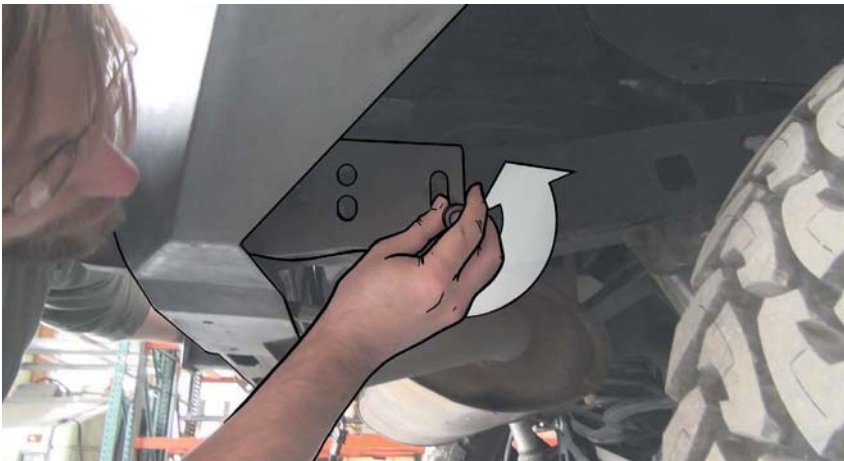

## **STEP 8 :**

Insert the two stock frame bolts, do not tighten them all the way.



## **STEP 9 :**

You may now let go of the bumper, the stock bolts will prevent it from falling off.



## **STEP 10 :**

Insert the 4" long bolts into the opening. The bottom hole should have been drilled by this point to provide a space for the bottom 4" bolt.



## **STEP 11 :**

After inserting the bolts, attach the frame backing plate onto the studs, then attach the nuts and washers.



## **STEP 12 :**

Attach the trailer plug to the provided safety chain plate.



## **STEP 13 :**

Locate the two horizontal bolts and align with the holes on the safety chain plate.

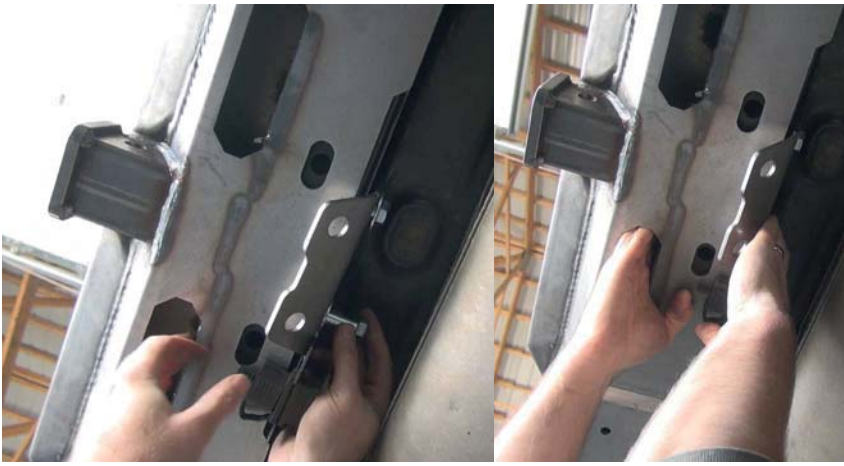

## **STEP 14 :**

Insert the bolts, and loosely thread on the nuts and bolts using the access hole cutouts.



## **STEP 15 :**

Insert two 1/2"x4" bolts into the two vertical holes that were drilled out earlier. Place the corresponding size nuts on the other side.



## **STEP 16 :**

At this point, we will be leveling\* the bumper.

\*Having a level bumper is crucial to the proper functioning of the carrier.\*



## **STEP 17 :**

Measure the gap between the bumper and Jeep body on both sides, the measurements should be equal.



## **STEP 18 :**

Tighten the stock bolts, one at a time on each side, one side at a time.



## **STEP 19 :**

As you go back and forth tightening the bolts, keep checking your gap measurements to make sure the bumper has not shifted.



## **STEP 20 :**

After tightening one bolt on the passenger/driver side, check your measurements then repeat in the corresponding bolt on the opposite side of the car.



## **STEP 21 :**

Use a wrench to reach and keep the nuts in place while you tighten the bolts.



## **STEP 22 :**

Using the access holes and the 3/4 wrenches, tighten the bolts that hold the safety chain plate to the crossmember.

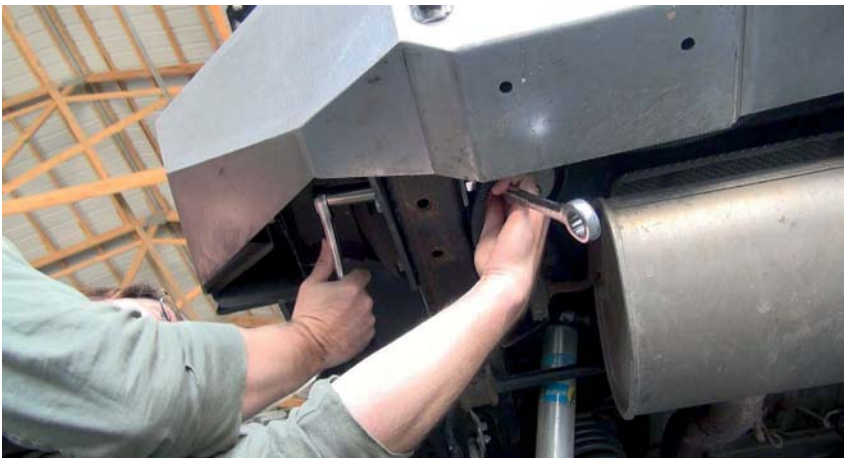

## **STEP 23 :**

Check that all of the bolts securing the bumper to the Jeep are tight now.



## **STEP 24 :**

Measure the middle and corner gaps between the Jeep body and the bumper to make sure it has not changed.



## **STEP 25 :**

Install the nub for the quick latch system, you may apply Locktite to the threads.



Using a 5/8" wrench on top and a 3/4" wrench on the bottom, tighten it down.



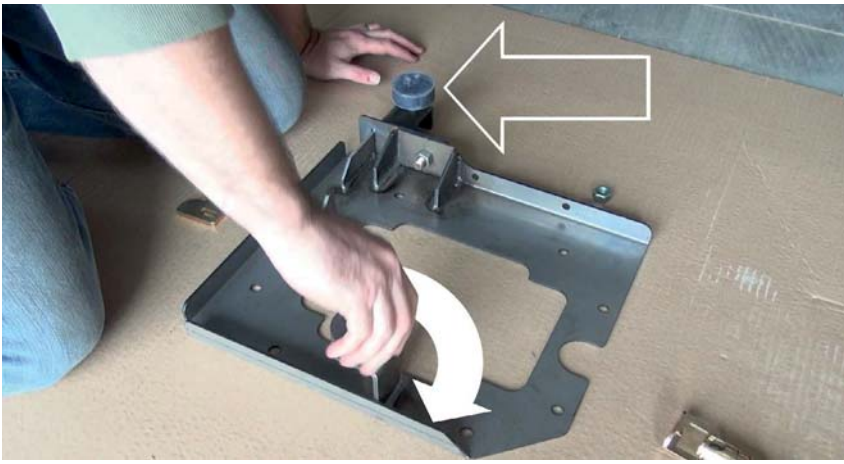

## **STEP 26 :**

Screw in the two rubber bumpers that came in the installation kit.



## **STEP 27 :**

Attach the alignment plate with the two 5/16" bolts provided in the install kit.



## **STEP 28 :**

Attach the door plate to the stock bolt holes on the Jeep door with the 8 stock bolts.



## **STEP 29 :**

At this point you should thoroughly pack BOTH of the wheel bearings with grease.

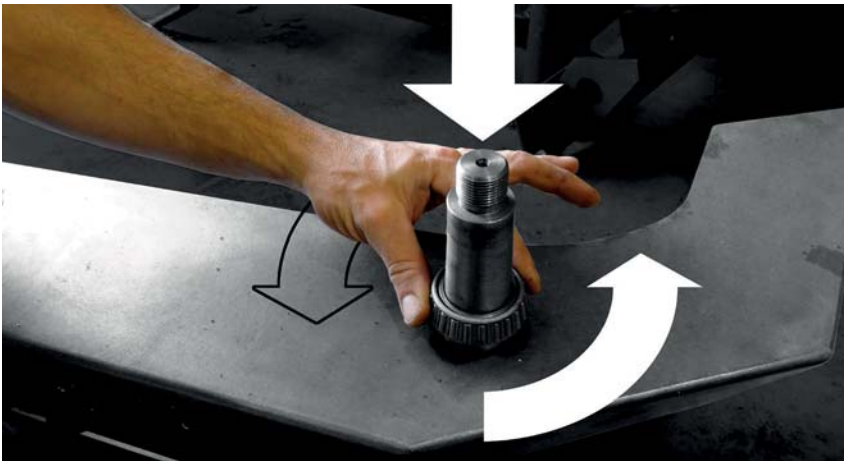

## **STEP 30 :**

Place bearing LM29749 onto the spindle, tapered side up. It should slide down all the way and spin freely. If not, you are using the wrong bearing.

Make SURE to check the bearing number to make sure you have the correct one. Mixing up the bearings can damage the spindle.

## **STEP 31 :**

Flip the carrier arm upside down, so the arm is horizontally on top.

Take the bearing from Step 30 and place it, taper down, into the opening.

Next, place the bearing seal on top of the bearing. The text on the bushing must face out.



## **STEP 32 :**

Do NOT use a hammer directly on the seal or you WILL deform/damage it or the carrier.

Use something soft like a block of wood to spread out the force as you lightly tap the seal into place, otherwise you will void your warranty.

## **STEP 33 :**

Under no circumstances should you force the bearings onto the spindle. If you find the bearing doesn't fit, polish/sand the spindle very slightly. Be careful to not take off too much material.





## **STEP 34 :**

Place the carrier arm down onto the spindle. Make sure to keep the welded tube portion perpendicular to the spindle.



## **STEP 35 :**

Place the top LM48548 bearing (greased in step 33) into the spindle, with the taper facing down.



## **STEP 36 :**

Place a washer onto the spindle, then the 1" spindle nut on top. Be sure to add Loctite to the spindle threads before you tighten the nut completely.



## **STEP 37 :**

Tighten down the nut with a 1- $\frac{1}{2}$ " socket, then add the top aluminum cap, and also tighten that with the 1- $\frac{1}{2}$ " socket.



## **STEP 38 :**

Test the swing arm operation by moving the door back and forth. The motion should be smooth and unobstructed.



## **STEP 39 :**

Attach the latch alignment guide to the back of the carrier with the provided  $\frac{5}{16}$ " hardware. Attach it loosely so that it can be shifted slightly.

If you plan on loading the carrier, (we used a tire) it will shift down slightly, so you may have to re-adjust it.

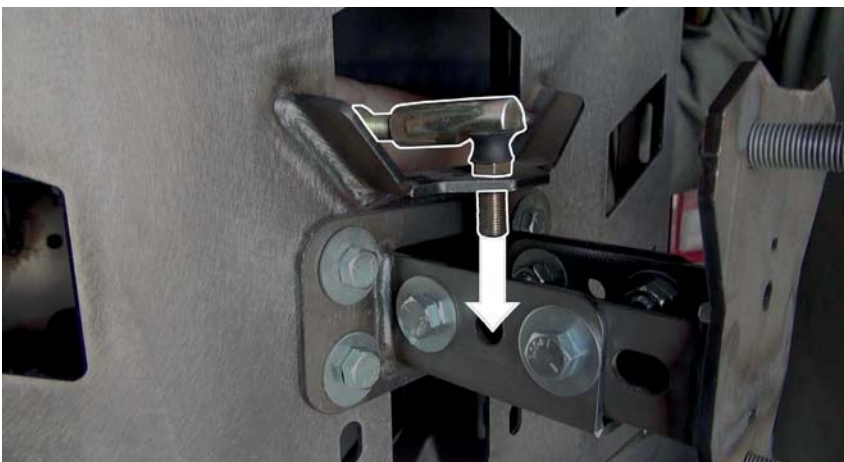

## **STEP 40 :**

Install the quick latch by inserting the threaded parts through the mount holes and attaching with the washers and  $\frac{1}{2}$ "-20 hex nuts on the other side.

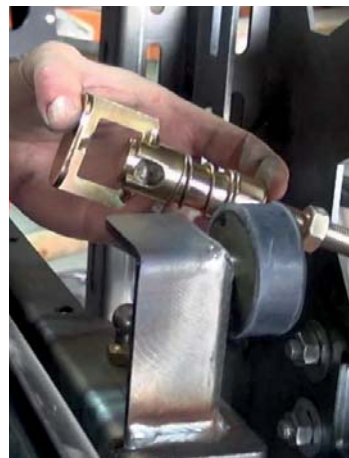

## **STEP 41 :**

Standing behind the Jeep door, grab the quicklatch with your left hand and slowly move the door until it is close enough for the latch to be operated.

Press down on the plunger with your thumb and swing the latch down onto the mount stud to attach the latch to the mount stud on the door plate.

TOP EDGE AND/OR CENTER MUST BE  
ALIGNED

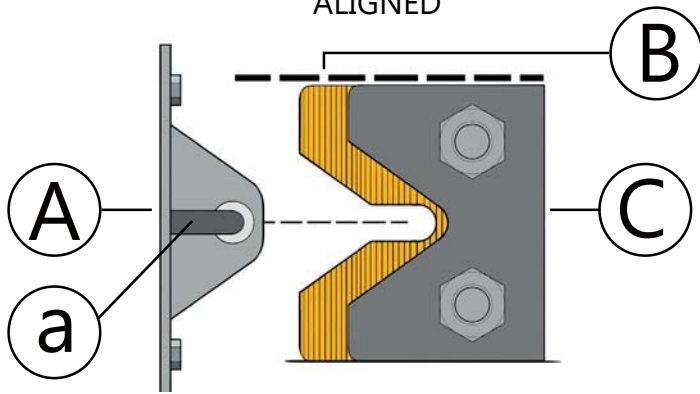

## **STEP 42 :**

Now carefully close the door, taking care to not slam it shut. It should shut and latch smoothly.

The alignment plate rod (a) should be centered to the cutout in (B). The top edges of (B) and (C) should line up.

## **STEP 43 :**

When the door is closed, the alignment plate should fit together smoothly. If it does not, adjust the height of (B)\* slightly.

\*references **Step 42**

## **STEP 44 :**

In order for the carrier to close and stay shut properly, the carrier arm face and bumper face must be flush to each other.

Use the jack screw to adjust (illustrated in **Step 46**).

**TIP 1 :** If you find that the carrier does not shut, make sure your rubber bumpers are not twisted too far out.

**TIP 2 :** If you find that the rubber bumpers are not long enough, again, check your mounting bolts and the level of the bumper.

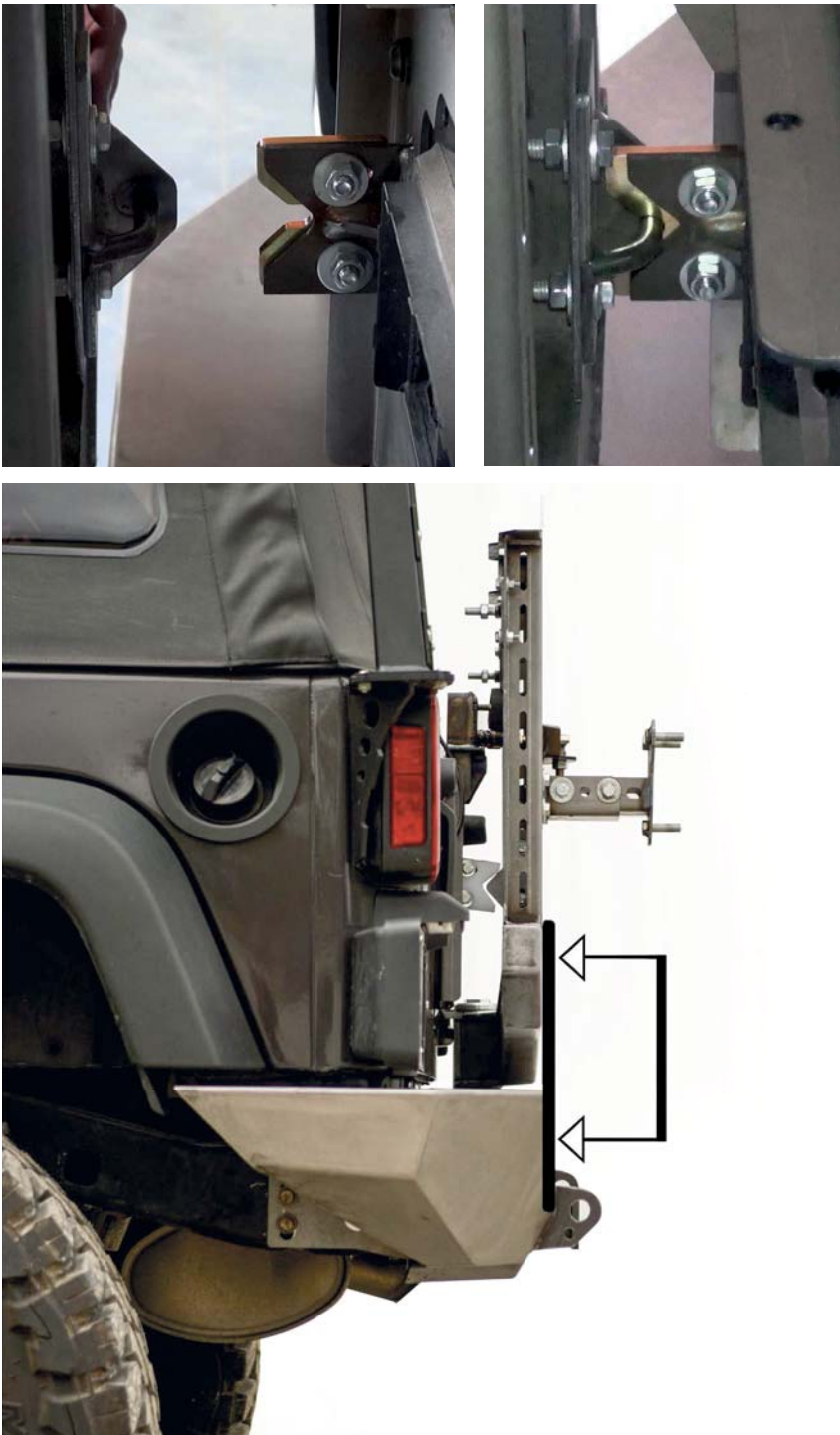



## **STEP 45 :**

Now carefully close the door, taking care to not slam it shut. It should shut and latch smoothly.

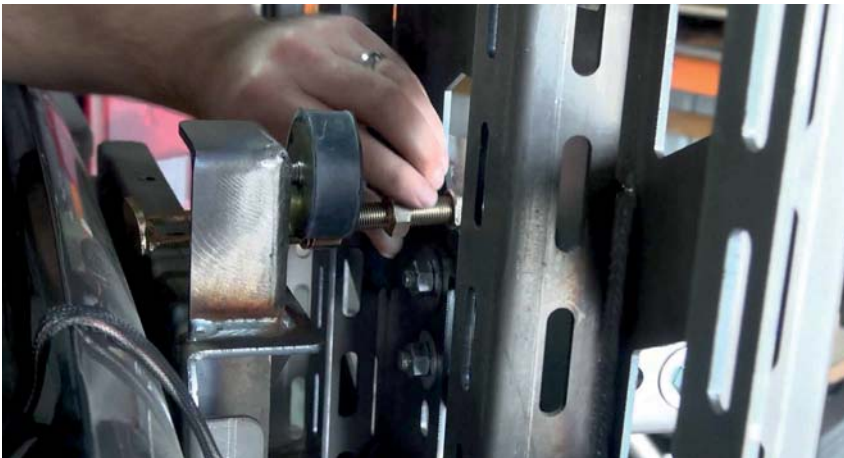

## **STEP 46 :**

The carrier must be latched and closed for this step!

Adjust the distance between the carrier and the Jeep by adjusting the jack screw on the quick latch system (shown in **Steps 40+41**). This will give the slight tilt toward the car illustrated in **Step 51**.



## **STEP 47 :**

After the quicklatch is adjusted, you can uncrew the rubber pucks so they press on the surface.

It may be tricky to get the slight lean as well as the faces flush on the carrier arm/bumper.



## **STEP 48 :**

The pucks must press on the surface pretty firmly, enough to keep a loaded carrier from rattling. So open the door and unscrew the pucks a couple more rotations, then shut the door to make sure they fit tightly. Repeat as necessary.



## **STEP 49 :**

Now attach both of the tire mounts to the carrier body. Use an  $\frac{11}{16}$ " wrench on the nuts and  $\frac{5}{8}$ " wrench on the bolts.

After this step, you should be ready to attach a spare tire or equipment.

## **STEP 50 :**

If you plan on loading the carrier with weight, (we used a 35" tire) plate A will shift down slightly, causing it to catch on B\*. To stop any interference, you will have to re-adjust B to be centered with A again after the carrier is loaded with its full weight.

\*reference diagram in **Step 42**



## **STEP 51 :**

This diagram illustrates final bumper fitment with the carrier shut. The top of the bumper is level to the body of the Jeep. The carrier is tilted slightly towards the vehicle.



**TIP 1 :** If you find that the carrier does not shut properly, **MAKE SURE** you check the level of the bumper to the vehicle body lines, as it may have shifted during installation.

**TIP 2 :** If you find that the rubber bumpers are not long enough, again, check your mounting bolts and the level of the bumper.



# Destroyer Rear Bumper/Tire Carrier Shipping Slip

TOP - LM48548

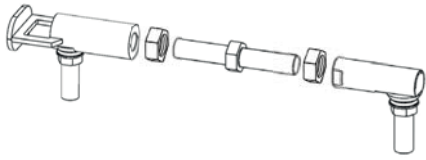

Ball Latch Assembly

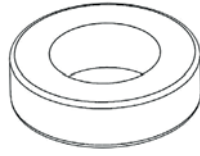

Spindle Seal Bushing



TOP - LM29749

Bearings

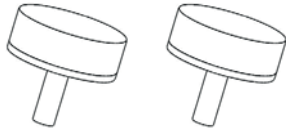

Rubber Isolator (x2)

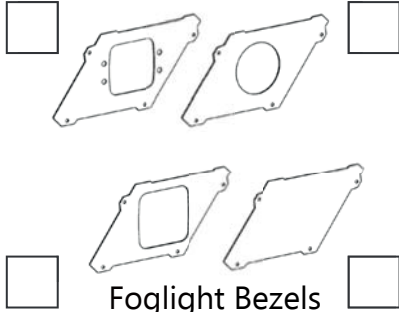

Foglight Bezels

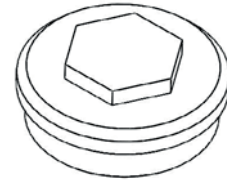

Spindle Top Cap

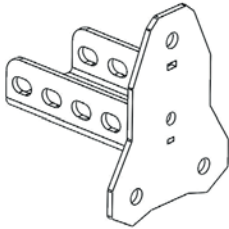

Tire Mount 1

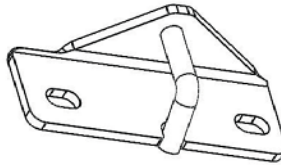

Alignment Guide 1

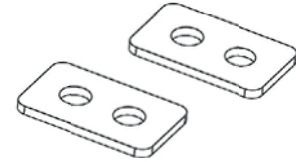

Frame Backing Plates

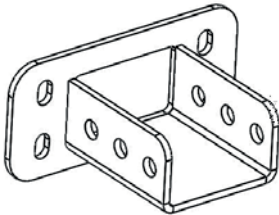

Tire Mount 2

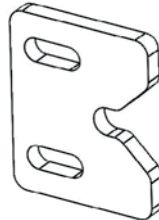

Alignment Guide 2

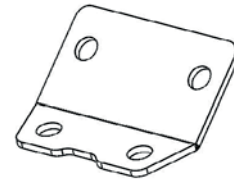

Safety Chain Plate

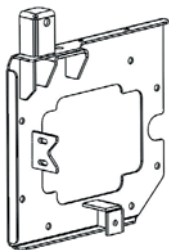

Door Plate

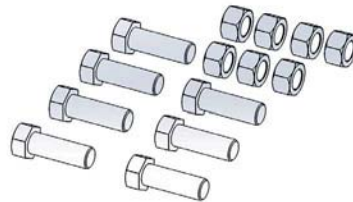

Bolt Kit - CONTENTS MAY VARY - Check Instructions



1/2" (13)  
x 4.5" Bolts

(x2)

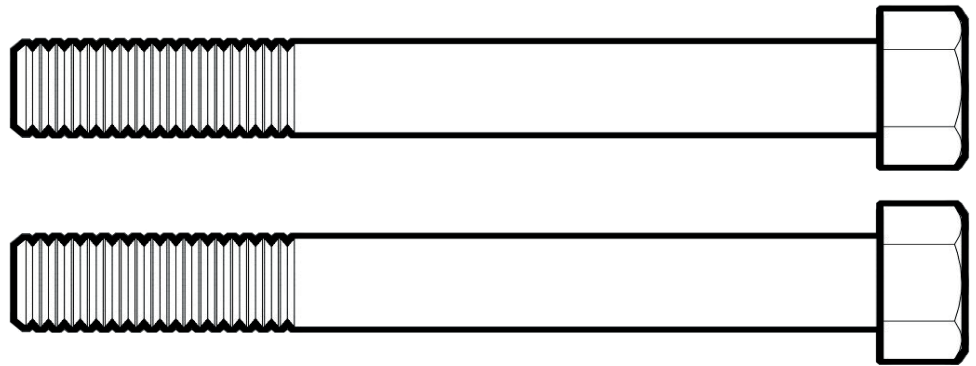

### Destroyer Rear Bumper/Tire Carrier Shipping Slip pt.1

\*please check contents when  
opening/assembling package

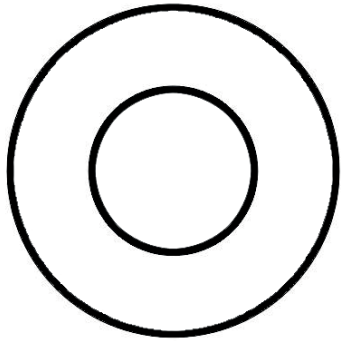

1" SPINDLE  
WASHER  
(x1)

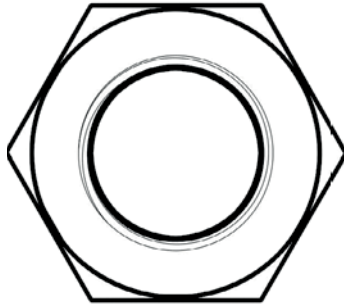

1" Spindle Nut  
(x1)



5/16" Nuts  
(x4)

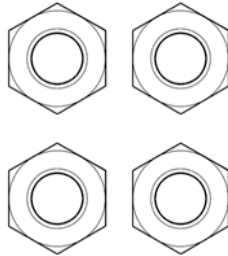

5/16 Washers  
(x8)

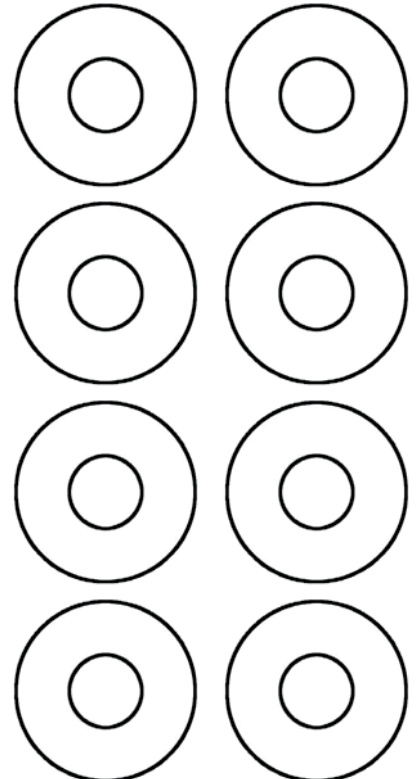

5/16 Bolts  
(x4)

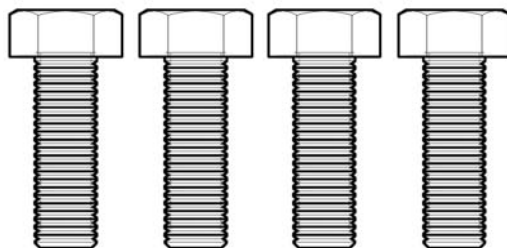

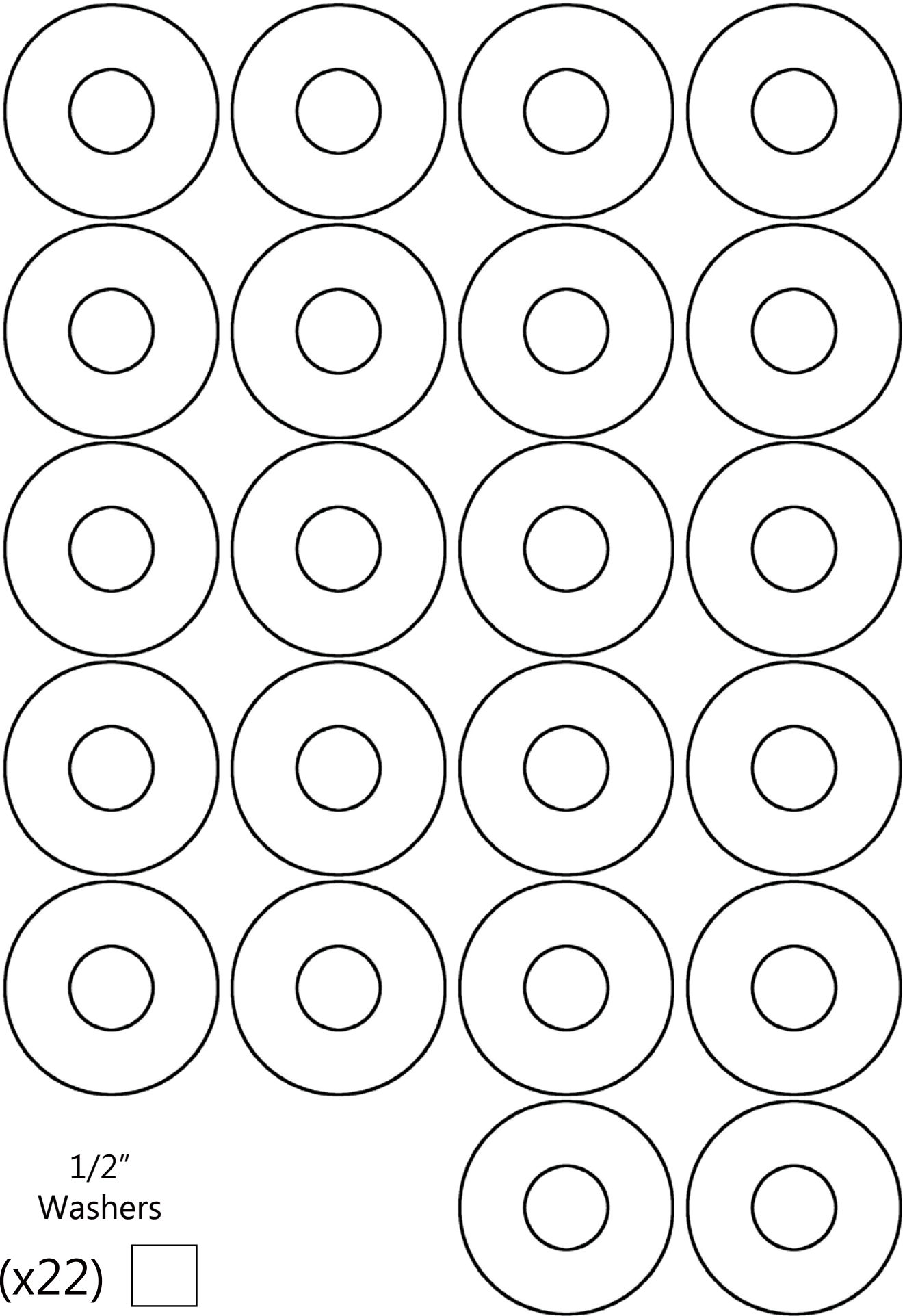

1/2"  
Washers

(x22)



# Destroyer Rear Bumper/Tire Carrier Shipping Slip pt.2

\*please check contents when  
opening/assembling package

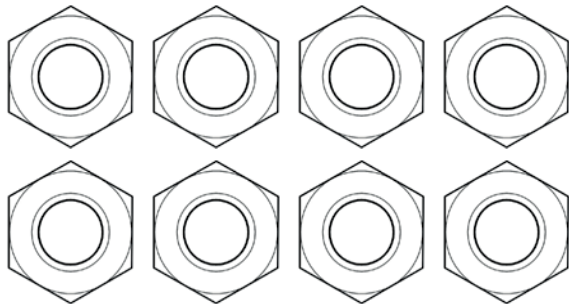
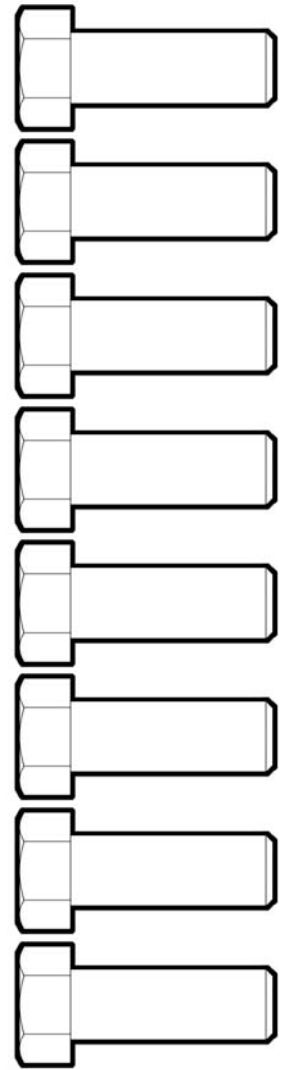
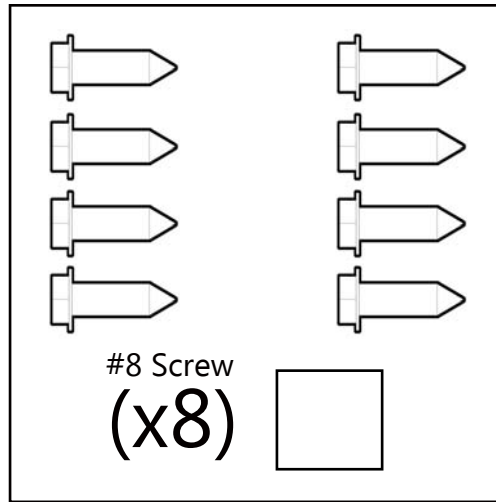

7/16" Nuts  
**(x8)**



7/16 (14)  
x 1" Hex Bolts **(x8)**



7/16" Washers  
**(x16)**

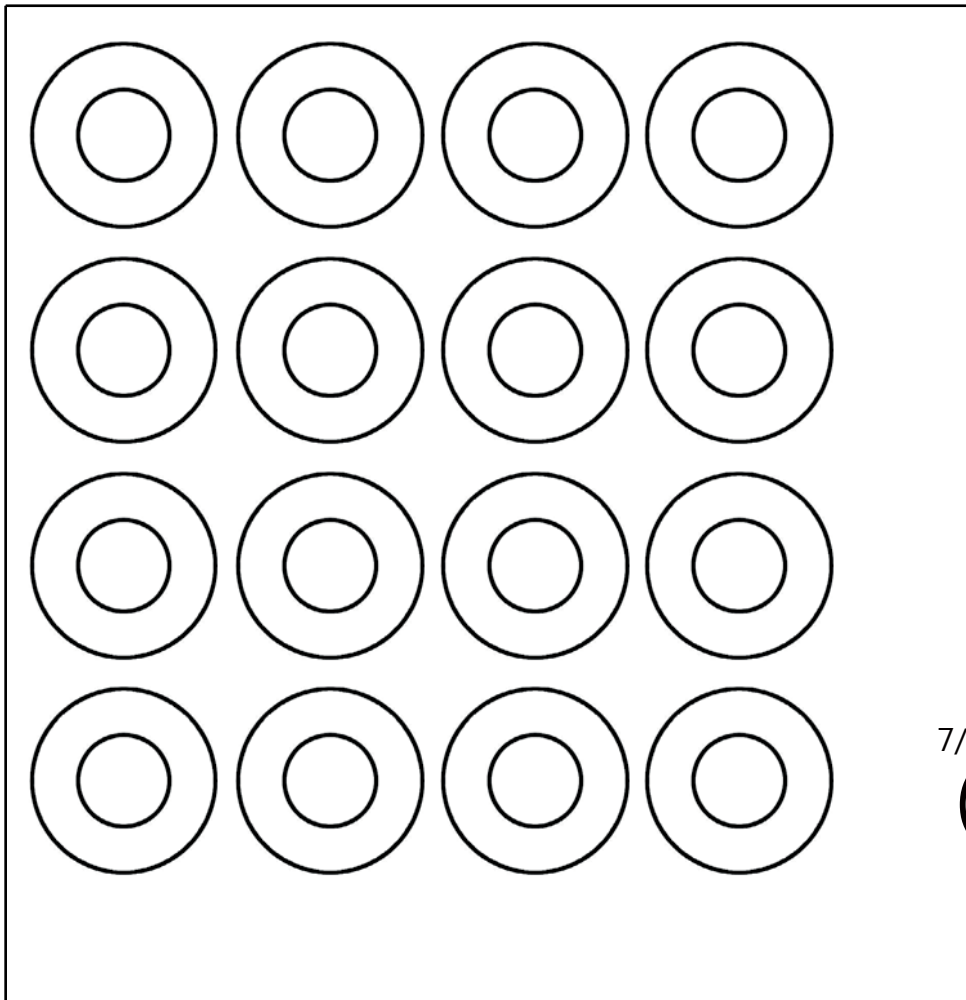

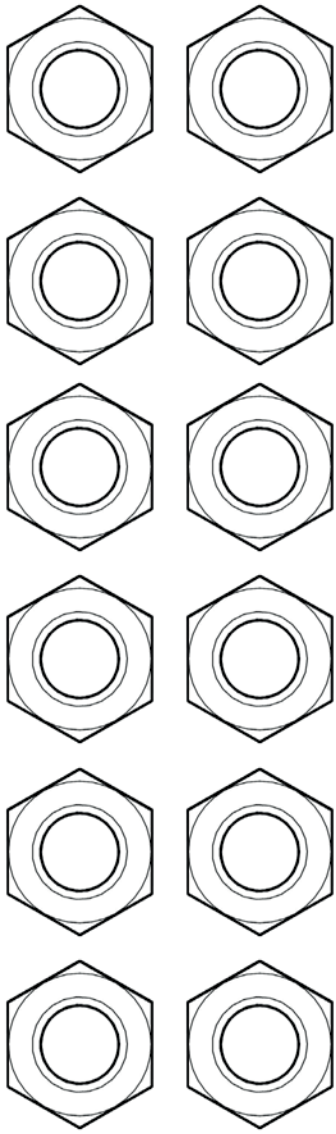

1/2"(13)  
Hex Nuts

(x10)

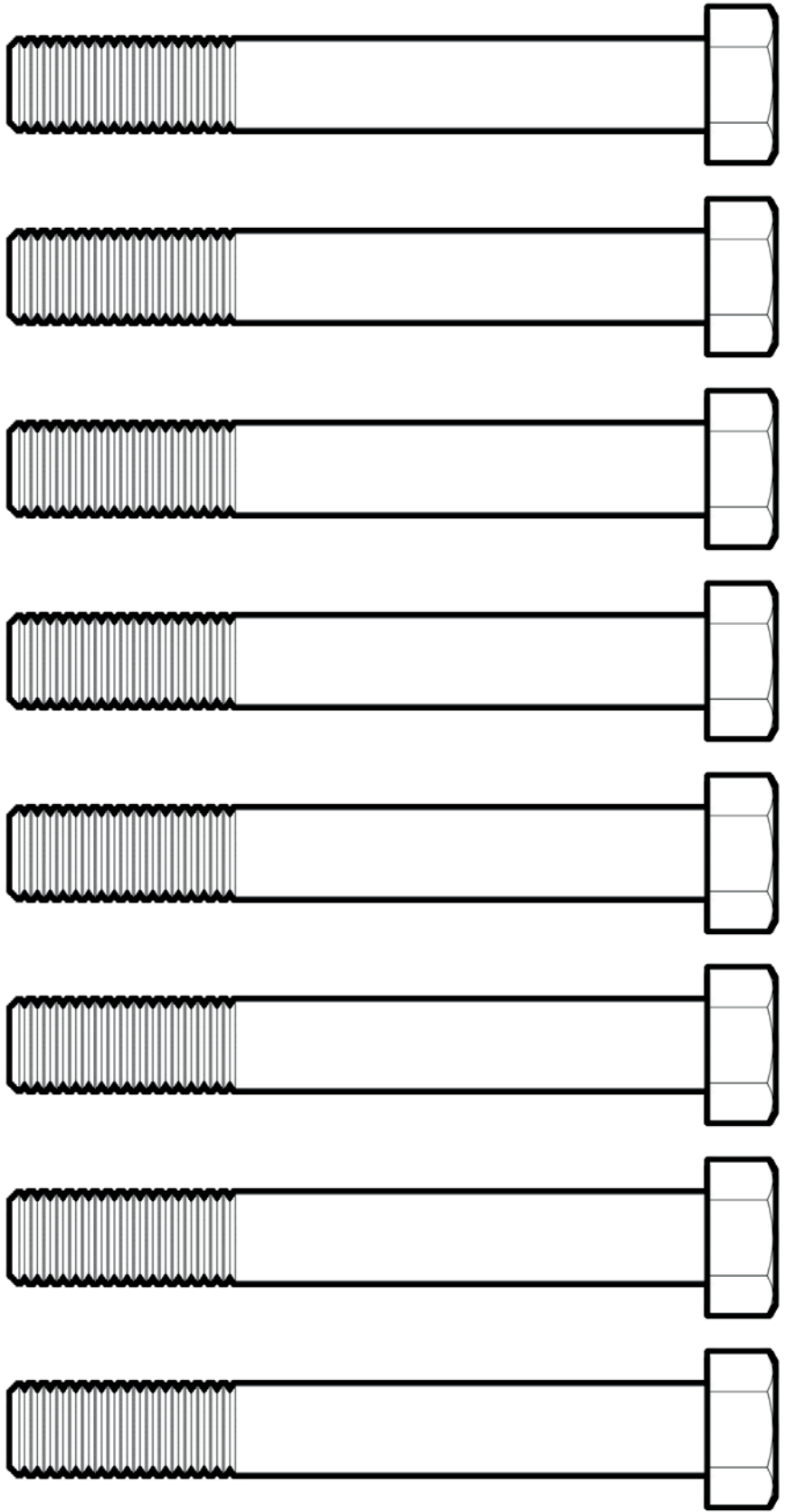

1/2"(13)  
x 4" Hex Bolts (x8)

Assembled By : \_\_\_\_\_

Date : \_\_\_\_\_

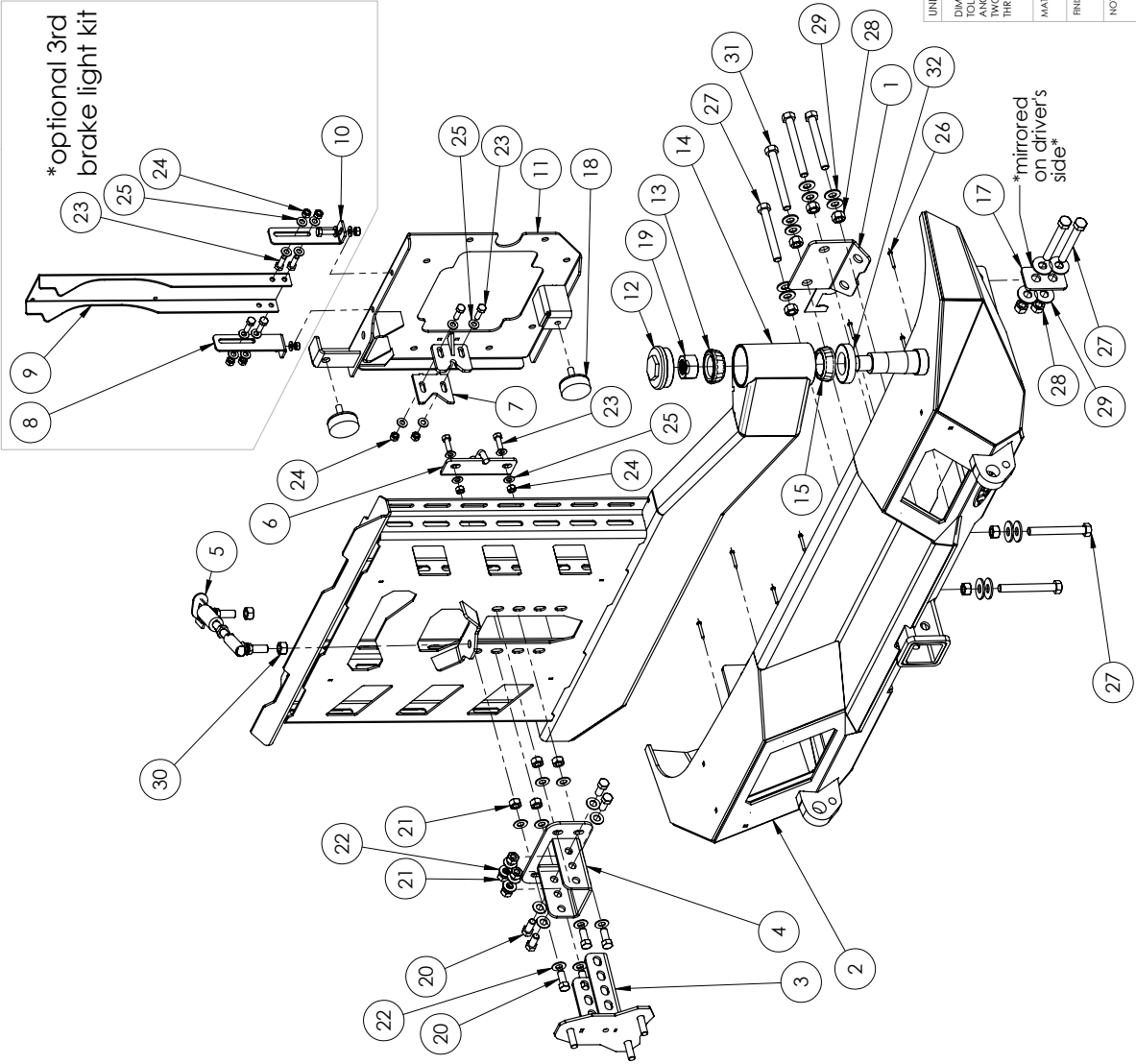

ITEM NO.	PART NUMBER	DESCRIPTION	QTY.
1	4JTC1001-10	Safety Chain Plate	1
2	JRB0700	Destroyer Rear Bumper	1
3	4JTC1001-03	Tire Mount 2	1
4	4JTC1001-04	Tire Mount 1	1
5	4JTC1001-09	Quick Release Latch	1
6	4JTC1001-07	Alignment Guide	1
7	2JTC1001-43	Alignment Plate	1
8	2JTC1001-49**	Driver Brake Light Bracket	1
9	2JTC1001-50**	Brake Light Arm	1
10	2JTC1001-48**	Pass. Brake Light Bracket	1
11	4JTC1001-02	Door Plate	1
12	2JC1002-03	Spindle Cap	1
13	LM48548	Top Tapered Bearing	1
14	4JTC1001-01	Tire Carrier Body	1
15	LM29749	Bottom Tapered Bearing	1
16	2JRB1001-24	Light Bezels	2
17	2JTC1001-51	Frame Backing Plate	2
18	2JTC1001-52	Rubber Isolator Pad	2

**HARDWARE**

19	HNI(14)	Purchased part (1"-.14 Nut)	1
20	HB 7-16(20) x 1	7/16 Hex Bolt	8
21	HN 7-16(20)	7/16 Hex Nut	8
22	7-16 Washer	Washer 0.4375	16
23	HB 5-16(24) x 1	5/16 Hex Bolt	4
24	HN 5-16	5/16 Hex Nut	4
25	5-16 Washer	Washer 0.3125	8
26	HB #8	#8 Small Hex Bolt	8
27	HB 1-2(13) x 4"	1/2(13)x4 Hex Bolt	8
28	HN 1-2(13)	1/2 Hex Nut	10
29	1-2 Washer	Washer 0.5	22
30	HN 1-2(20)	Nut (Washer) 0.5"	2
31	HB 1-2(13) x 4.5"	4.5" Hex Bolt (safety chain)	2
32	Seal 450068	Timken Seal 450068	1

ALL PARTS MARKED WITH A DUAL ASTERISK "\*" ARE OPTIONAL AND MUST BE PURCHASED SEPARATELY

UNLESS OTHERWISE SPECIFIED		NAME	DATE
DRAWN	VZ	LOD LLC.	10/25/16
CHECKED		DESCRIPTION:	
ENG APPR.			
MFG APPR.			
Q.A.			
COMMENTS: PROPRIETARY AND CONFIDENTIAL THE INFORMATION CONTAINED IN THIS DRAWING IS THE PROPERTY OF LOD LLC. ANY REPRODUCTION IN PART OR AS A WHOLE WITHOUT THE WRITTEN PERMISSION OF LOD LLC IS PROHIBITED.			
MATERIAL		SIZE	DWG. NO.
FINISH		<b>B</b>	JBC0700
NOTE		SCALE: 1:24	WEIGHT:
			SHEET 1 OF 7