



SIGNATURE SERIES  
**2 DOOR JK**  
ROCK SLIDERS  
**INSTALLATION**



1. To remove either the Jeep JK Wrangler Unlimited Rubicon rocker guards or Sahara running boards, use a 10mm wrench to remove the 3 pairs of nuts securing them to the body pinch seam.



2. Using a 13mm socket, remove the 3 bolts securing the Rubicon factory rocker guards or Sahara running boards to the bottom of your Jeep JK Wrangler Unlimited's body.



3. With the 6 nuts and 3 bolts removed, the factory rocker guards or running boards on your Jeep JK Wrangler Unlimited Rubicon or Sahara should pull off the body pinch seam with ease. Set them aside.



4. Starting on the driver side of your Jeep JK Wrangler, use an 18mm socket to remove the bolts securing the automatic transmission and transfer case skid plates to the frame rail.



5. Determine which slider is the Driver Side. To accomplish this simply measure the length of the mounts. The shorter mount is the end of the slider which faces the front of the Jeep.

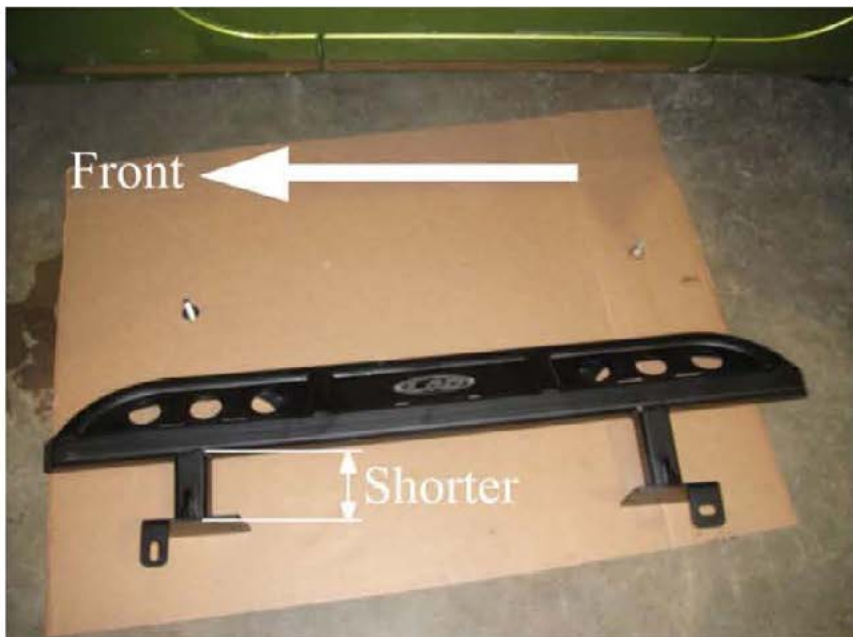



6. Using the factory hardware, secure your new LoD Signature Series Rock Slider to the points where the automatic transmission and transfer case skid plates attach the frame rail on your Jeep JK Wrangler. An 18mm socket will be needed for this job.

(Note: If your jeep has a manual transmission you will need spacers to make up thickness of this cross-member. If no spacers are used the sliders will not follow the body line.)



MANUAL TRANSMISSION JEEPS DO NOT HAVE THIS PLATE



**Important:** Before marking or drilling any holes be sure to make sure that the slider is positioned properly. The slider needs to be aligned so that it maintains an even spacing between it and the pinch seam of the body.

The customer is required to use washers (NOT Supplied by LOD) to make up the gap from the missing cross member on Jeeps with a manual Transmission.



The large **Bottom Stamped Hole** is already there for the 4" bolt.

**\*\*Optional\*\*** The **Top Hole** marked with the arrow can be marked and drilled for a **7/16" -20** tap (so the drill bit will be slightly undersized.)

**Go through one side of the frame**, so you can insert the **7/16" x 1"** bolt.

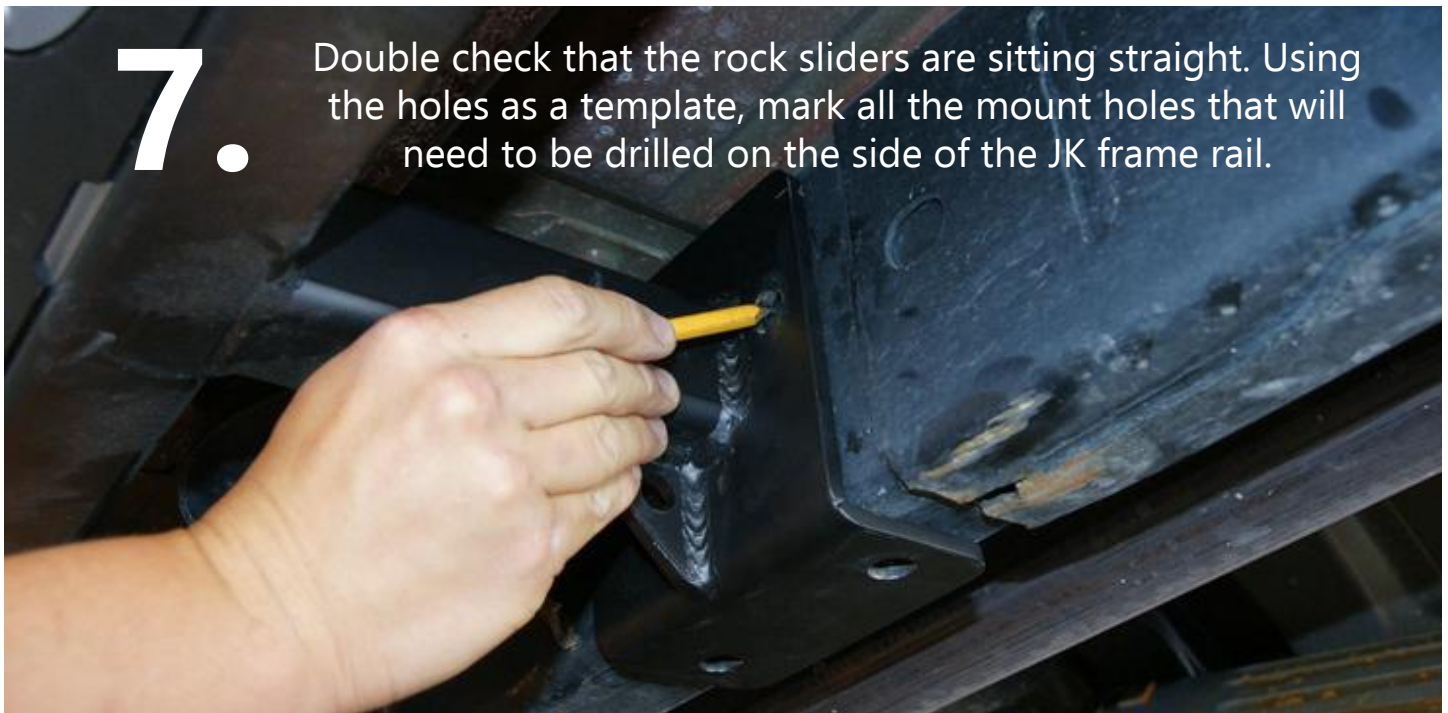

Double check that the rock sliders are sitting straight. Using the holes as a template, mark all the mount holes that will need to be drilled on the side of the JK frame rail.



# 8.

On the mount closest to the rear tire, there are two holes that will need to be marked off on the bottom as well.



# 9.

Remove the two bolts securing your sliders to the frame rail and carefully lower and remove them.

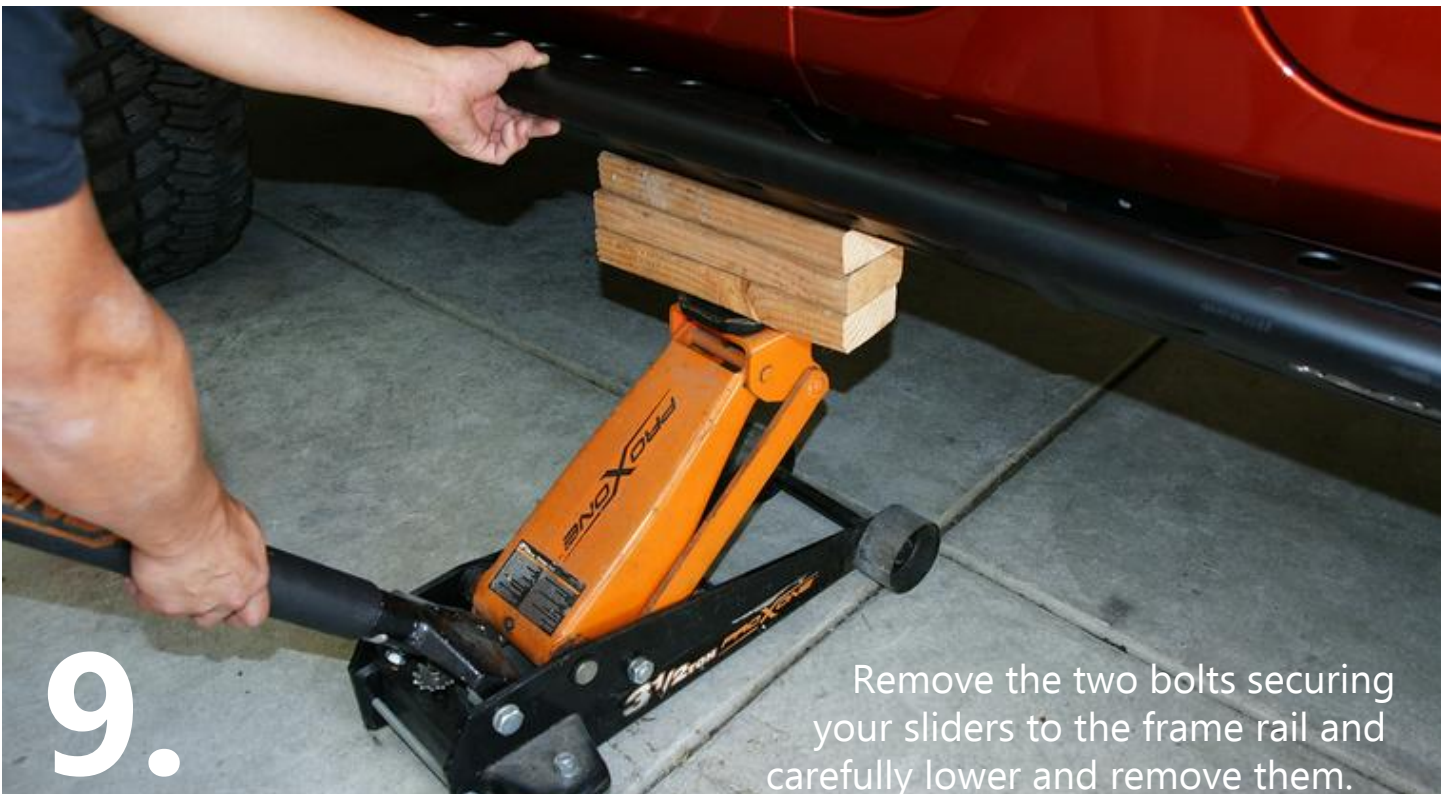

**10.** With your LoD Signature Series Rock Slider set aside, locate and mark the center of all the holes you need to drill out with a center punch. This will help keep your drill bit from wandering away once you start drilling.



**11.** Using a small metal drilling bit or Unibit, begin drilling pilot holes on all the mounting points on you've marked off your Jeep JK Wrangler's frame rail.



**12.** If you don't have one already, you really need to pick up a matched 7/16" x NF20 Drill Bit and Tap Set like the one shown above.





**13.** Using the drill bit that comes with the drill and tap set, finish drilling out all the pilot holes that you made back on step #11.



**14.** If you don't have some already, I would highly recommend that you pick up some cutting oil as it will help make tapping your mounting holes a whole lot easier.



**15.** With the help of some cutting oil, slowly and carefully tap all your mounting holes. Due to the body of the Jeep JK Wrangler being in the way, you will not be able to use a standard tap handle to do this. I improvised and used a wrench to do this job.  
JRS0720INS - REV 3



**16.** Place your LoD Signature Series Rock Slider back on a floor jack and carefully maneuver in place under your Jeep JK Wrangler's driver side rocker panel.



**17.** Using the factory hardware, secure your new LoD Signature Series Rock Slider to the points where the automatic transmission and transfer case skid plates attach the frame rail on your Jeep JK Wrangler. An 18mm socket will be needed for this job.



**18.** Using the 7/16"x1" bolts that come with the kit, secure your LoD Signature Series Rock Slider onto the new mounting holes that you made on your Jeep JK Wrangler's frame rails





**20.** Repeat this process on the passenger side of your Jeep JK Wrangler.



ITEM NO.	PART NUMBER	DESCRIPTION	QTY.
1	4JRS0720-05	JK SIG SLIDER PASS SIDE WELDMENT	1
2	4JRS0720-06	JK SIG SLIDER DRIVER SIDE WELDMENT	1
<b>HARDWARE / BOLT KIT</b>			
ITEM NO.	PART NUMBER	DESCRIPTION	QTY.
3	2JRS0720-07	END COVER PLATE A	2
4	2JRS0720-08	MIDDLE COVER PLATE	2
5	2JRS0720-09	END COVER PLATE B	2
6	LOD Logo	Logo	2
7	2JRS0740-37	JK SID SLIDER SPACER	2
8	HB501364ZFGR5	HEX BOLT 1/2-13 X 4.00 HEX BOLT ZINC PLATE GR5	2
9	HN5013ZPGR5	HEX NUT 1/2-13 ZINC PLATE GR5	2
10	FW5022ZP	FLAT WASHER Ø1/2" X 1.375" ZINC PLATE	2
11	BHSCS 1/4-20 X 0.50 ZINC PLATE	BHSCS 1/4-20 X 0.50 ZINC PLATE	24
12	HB432016ZPGR5	HEX BOLT 7/16-20 X 1.00 HEX BOLT ZINC PLATE GR5	6
13	FW4318ZP	FLAT WASHER Ø7/16 X 1.25" ZINC PLATED	6

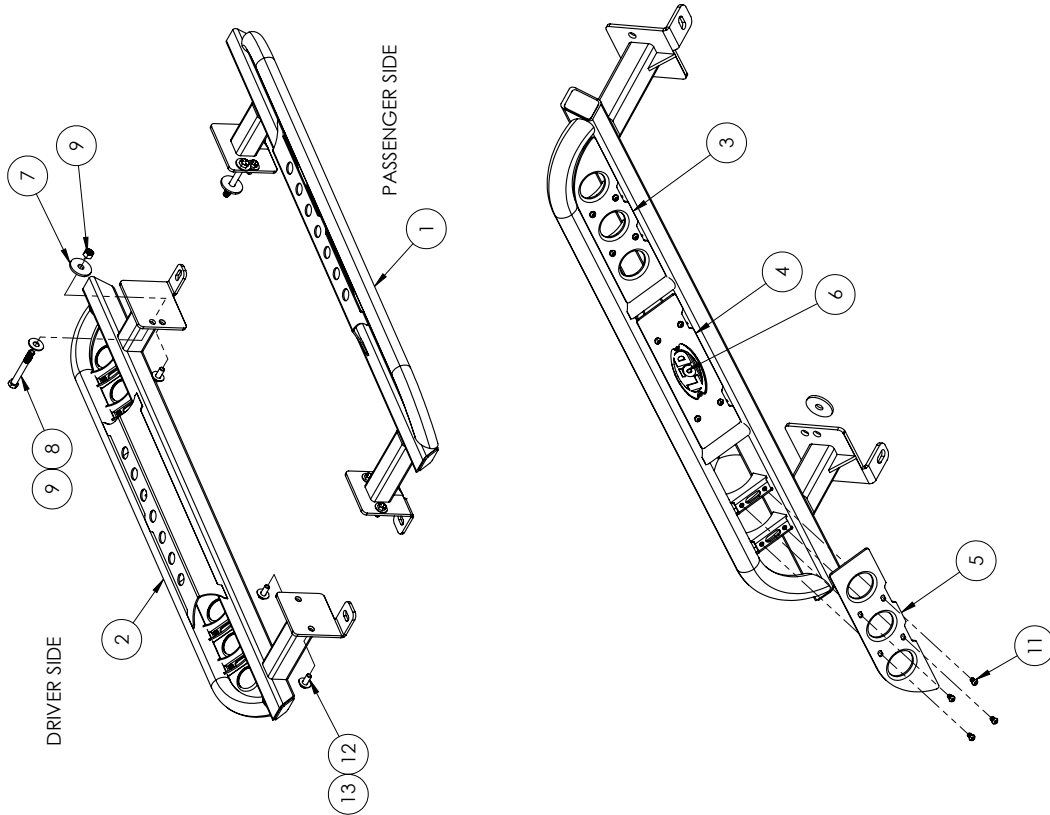

**NOTES:**  
 1. JRS0720 = BARE STEEL OPTION  
 2. JRS0721 = BLACK POWDER COAT OPTION

UNLESS OTHERWISE SPECIFIED:	NAME	DATE
DIMENSIONS ARE IN INCHES	MCH	10/14/2019
TOLERANCES ARE IN INCHES		
ANGULAR: MACH ±1°	CHECKED	
TWO PLACE DECIMAL ±0.015	ENG APPR.	
THREE PLACE DECIMAL ±0.005	MFG APPR.	
<b>PROPRIETARY AND CONFIDENTIAL</b>	MATERIAL:	
THE INFORMATION CONTAINED IN THIS DRAWING IS THE SOLE PROPERTY OF LOD LLC. ITS REPRODUCTION IN PART OR AS A WHOLE WITHOUT THE WRITTEN PERMISSION OF LOD LLC IS PROHIBITED.	N/A	
SEE NOTES	DWG. NO.	JRS0720
1040	JRS0721	
	SCALE: 1:10	SHEET SIZE: B
		SHEET 1 OF 1



**DESCRIPTION:**  
 JK SIGNATURE SERIES FRAME  
 MOUNTED 2 DOOR ROCK SLIDERS





**JK Jeep**  
**Signature Series**  
2 DR Rock Sliders  
Hardware Sheet

Packaged by: \_\_\_\_\_  
On: \_\_\_\_\_

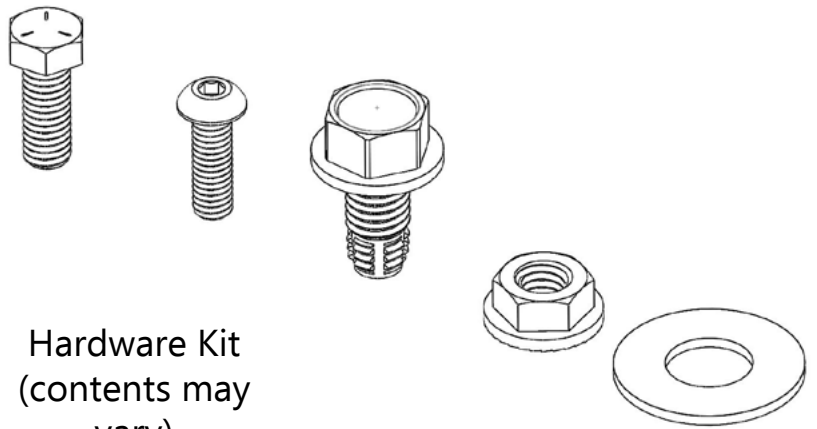

Hardware Kit  
(contents may vary)

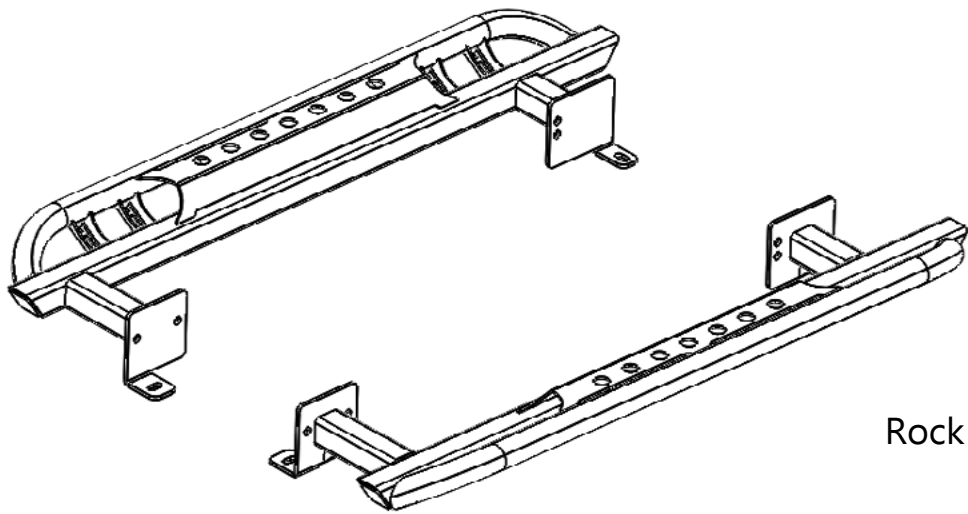

Rock Sliders

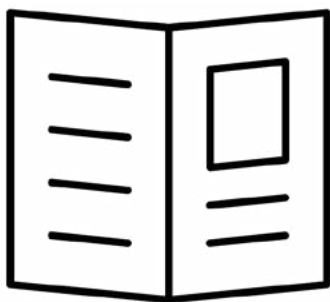

Rock Slider Instruction Booklet



**JK Jeep**  
**Signature Series**  
2DR Rock Sliders  
Packing Slip  
Packaged by:

On: \_\_\_\_\_  
\_\_\_\_\_

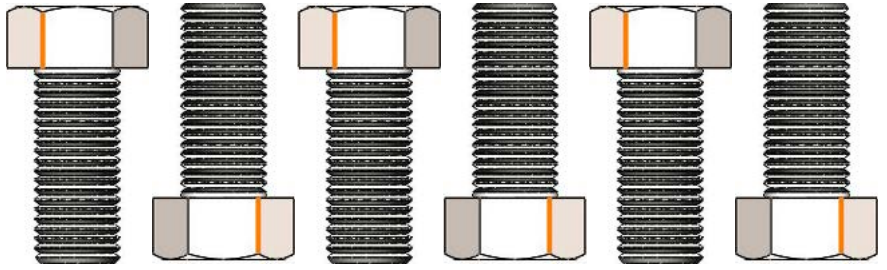

**7/16"-20 x 1" Hex Bolt**

**(6)**

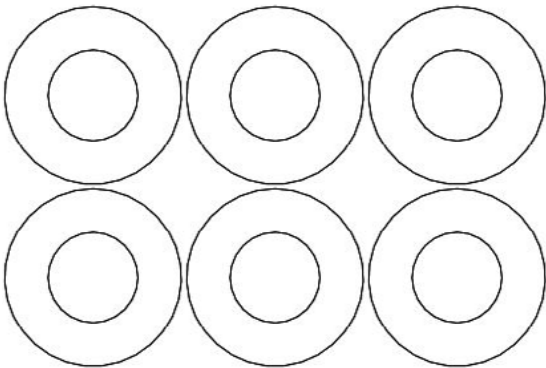

**7/16" Flat Washers**

**(6)**



**1/2"-13 x 4" Hex Bolts**

**(2)**





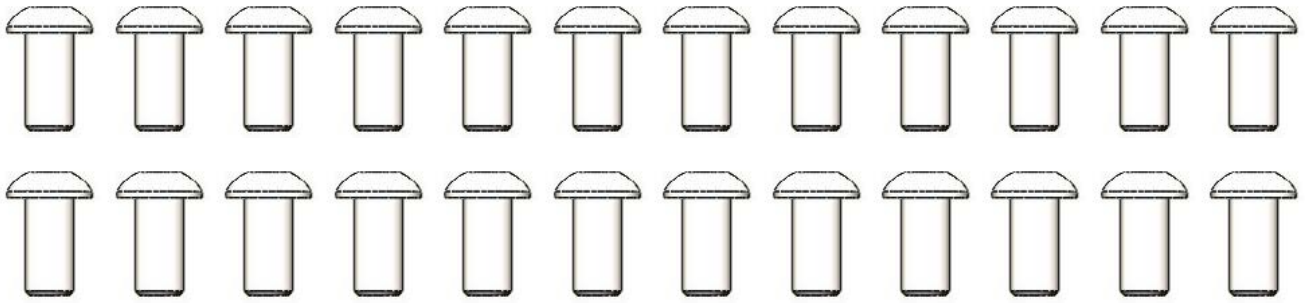

1/4"-20 x 0.5"  
Buttonhead  
Bolts

**(24)**



1/2" Flat Washers

**(2)**

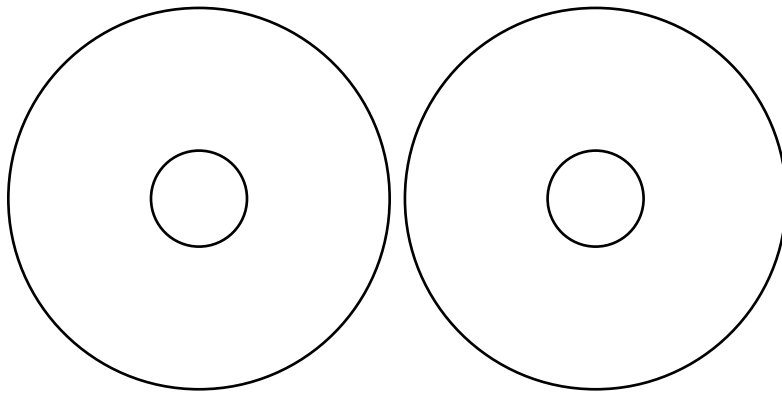
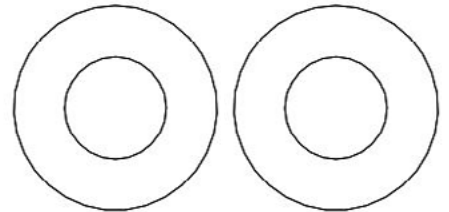

Large Flat Washers  
2JRS0740-37

**(2)**

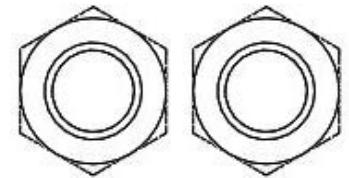

1/2"-13 Hex Nuts

**(2)**



LOGO

**(2)**



- shipped **separate** if bare steel
- **installed on sliders** if sliders are powdercoated

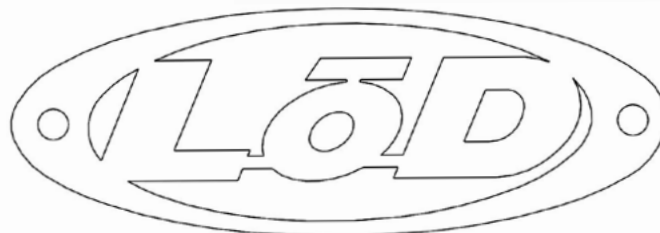
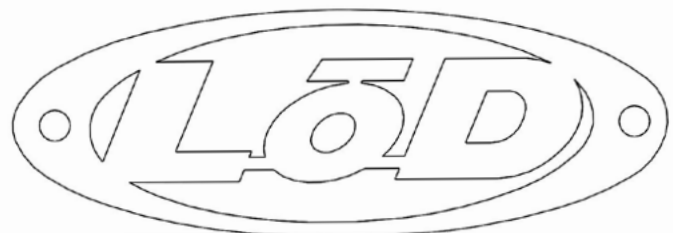

# Cosmetic Panels (Included)

## Front / Rear Panel (x2)

- opposite sides

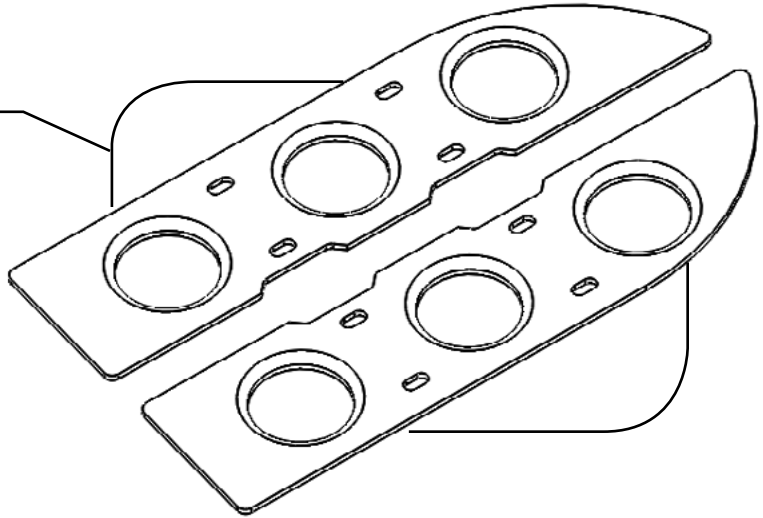

## Middle Panel (x2)

- logo installed if powdercoated  
- logo packaged separate if bare steel

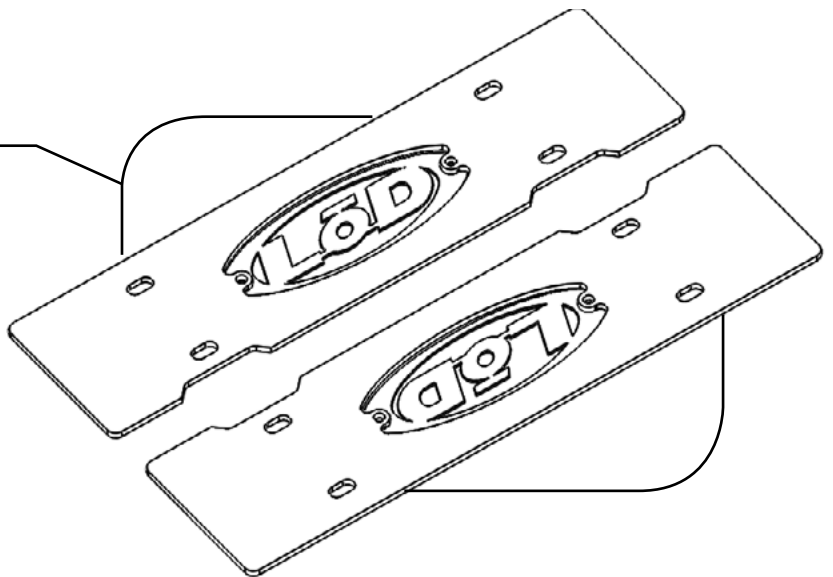

## Front / Rear Panel (x2)

- opposite sides

