



DESTROYER SERIES
JL JEEP
ROCK RAILS

**INSTALLATION
INSTRUCTIONS**

***PLEASE READ THROUGH THE INSTRUCTIONS BEFORE BEGINNING ANY PART OF THE
INSTALLATION PROCESS***

WEB LINK: <http://lodoffroad.com/assets/pdfs/JRS1814INS.pdf>

1.



Remove the stock rock sliders (if included on vehicle)

The rock sliders mount in the shown areas.

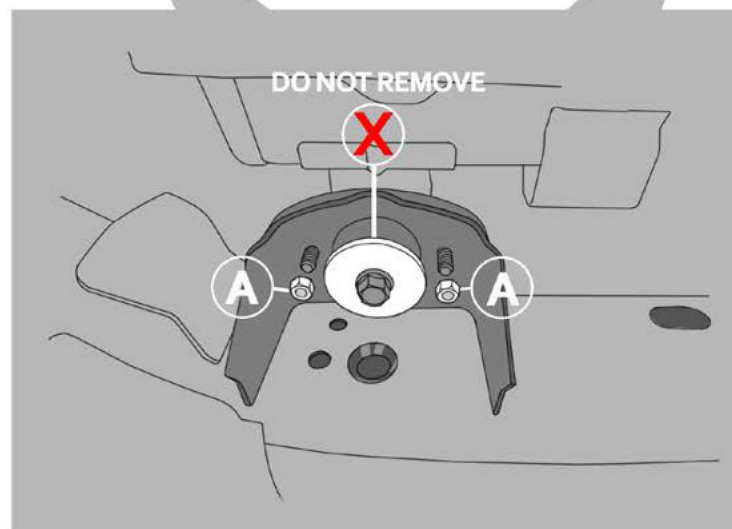
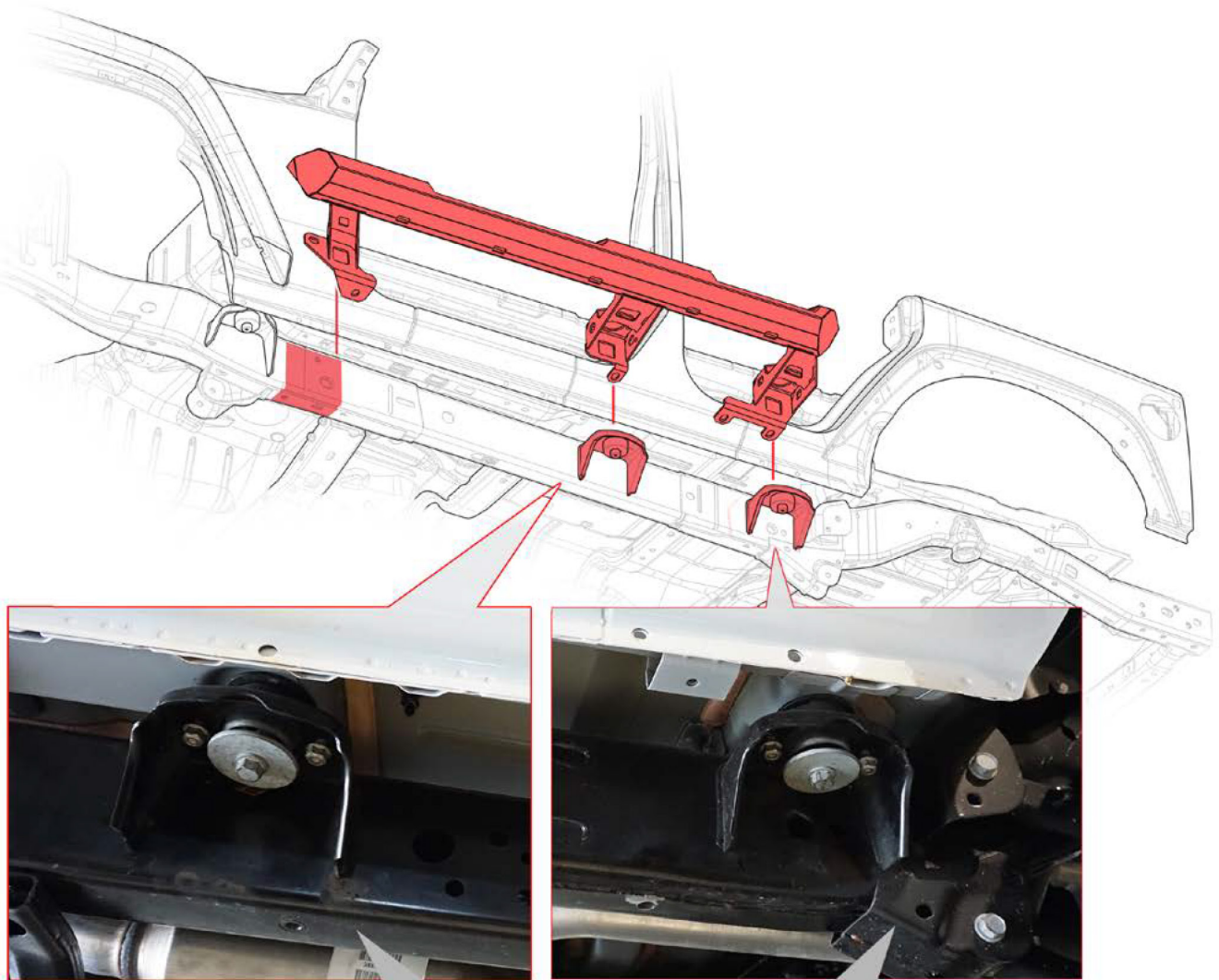

Remove the nuts in position "A"

You may need to loosen body bolt "X" to get mounts over washer, but DO NOT REMOVE.

CENTER AND REAR MOUNTS - (DRIVER SIDE SHOWN)

Refer to hardware sheet for the bolt legend

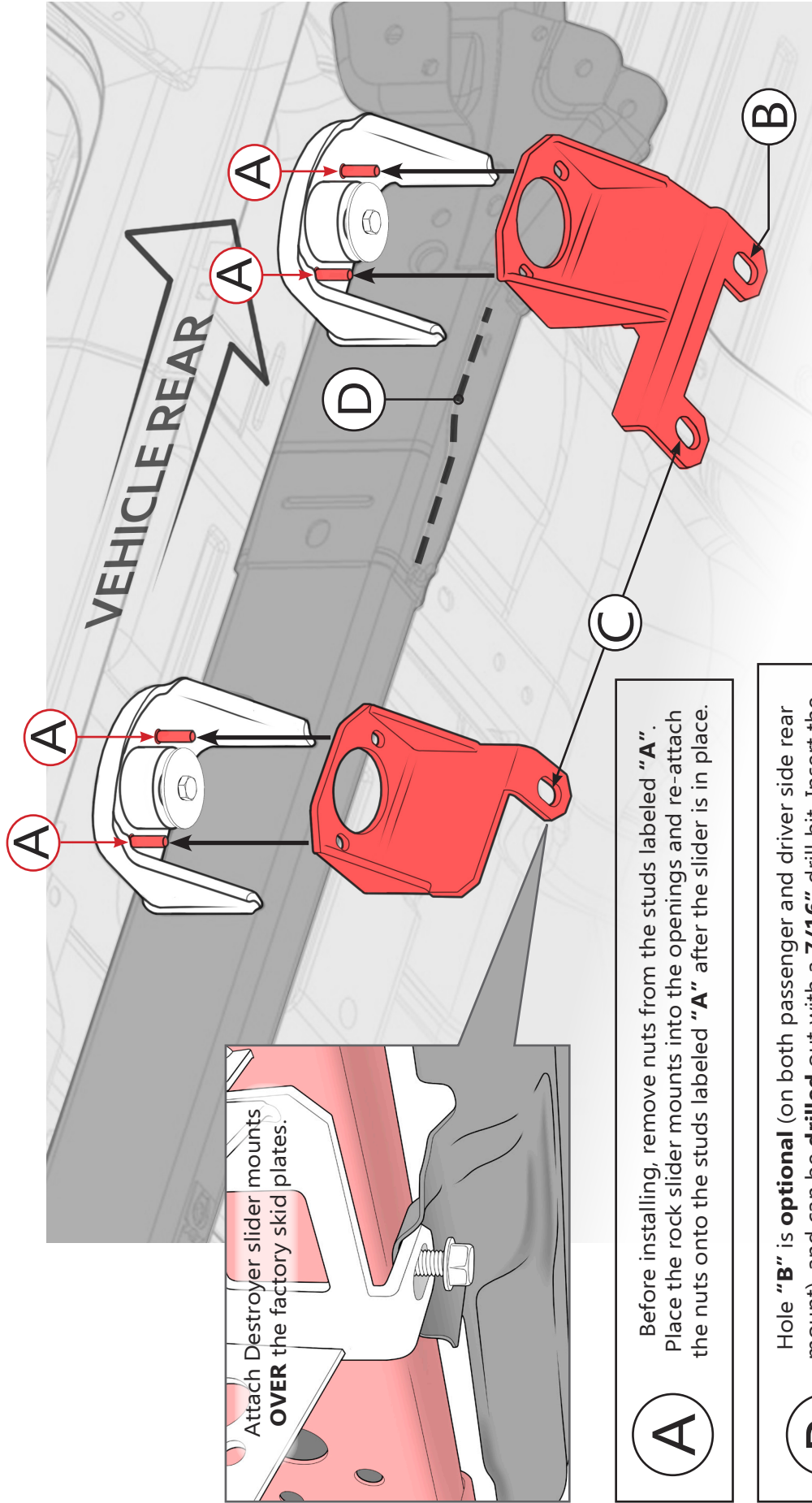

A Before installing, remove nuts from the studs labeled "A". Place the rock slider mounts into the openings and re-attach the nuts onto the studs labeled "A" after the slider is in place.

B Hole "B" is **optional** (on both passenger and driver side rear mount), and can be **drilled** out with a **7/16"** drill bit. Insert the provided self-tapping thread roller bolts (labeled "B" on the hardware sheet) and slowly tighten them until fully seated.

C We will supply hardware for holes labeled "C" on the **DRIVER** side. You will **re-use the stock bolts** that are already there on the **PASSENGER** side. Use bolts + washers labeled "C."

D Some welds and seams may need to be ground flat with a hand grinder. The dashed line, labeled "D," indicates where we had to grind a drippy weld.

FRONT MOUNT - (Passenger side illustrated for example, both sides are the same)

****Refer to hardware sheet for the bolt legend****

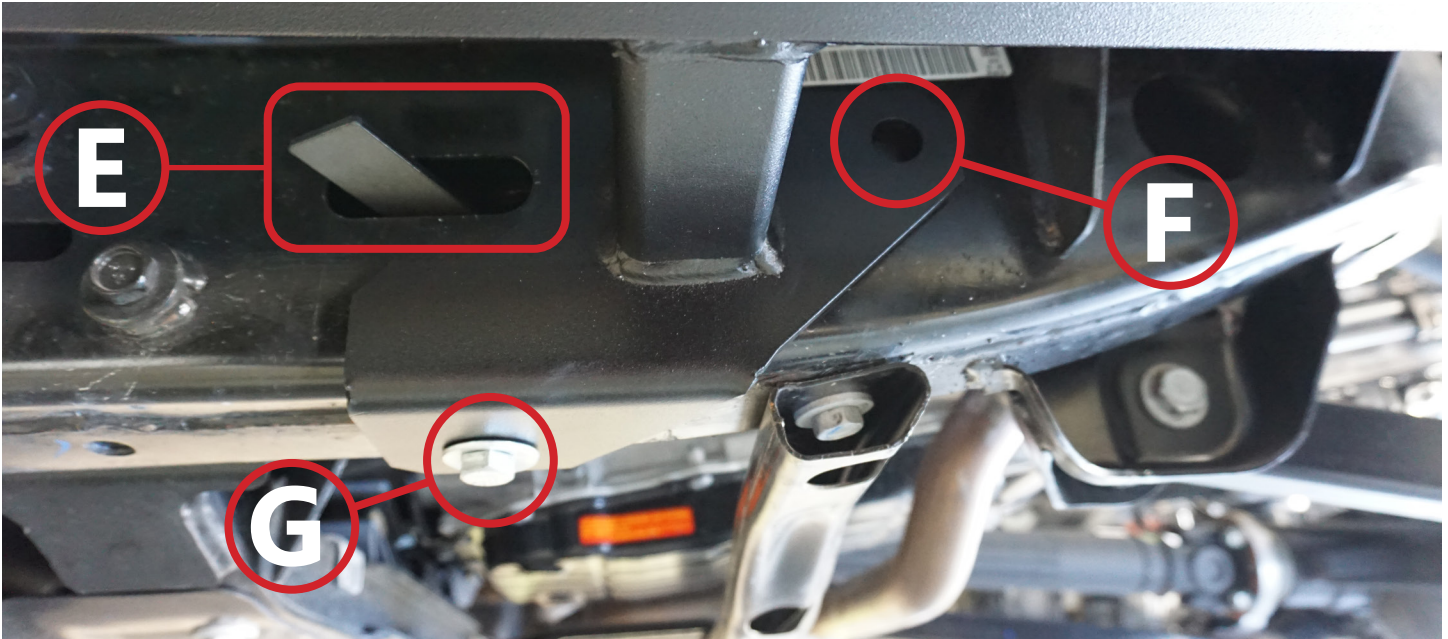

E Insert the flag nut labeled “E” into the rectangular hole.

G Attach bolt “G”, lining it up with the flag nut hole in step “E.”

F Hole “F” is optional, but is *recommended* for off-road use. Mark the hole location using the template provided on the next page, then use a **9/16”** drill bit to drill THROUGH the frame (on the passenger side only, the driver’s side has a hole.) Use bolts labeled “F” on the passenger and driver side. Insert two 0.5” washers between frame and mount, to fill the gap if needed.

Thoroughly tighten all of the bolts, and you should be all set!

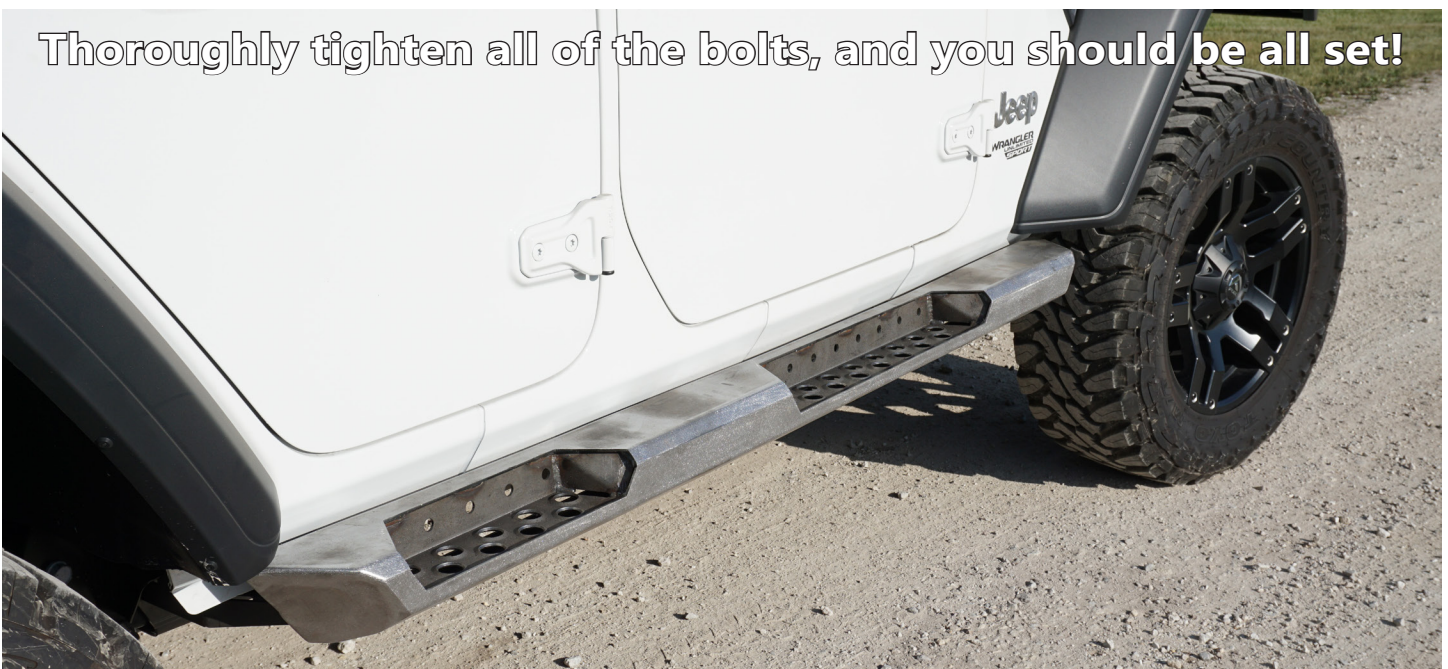

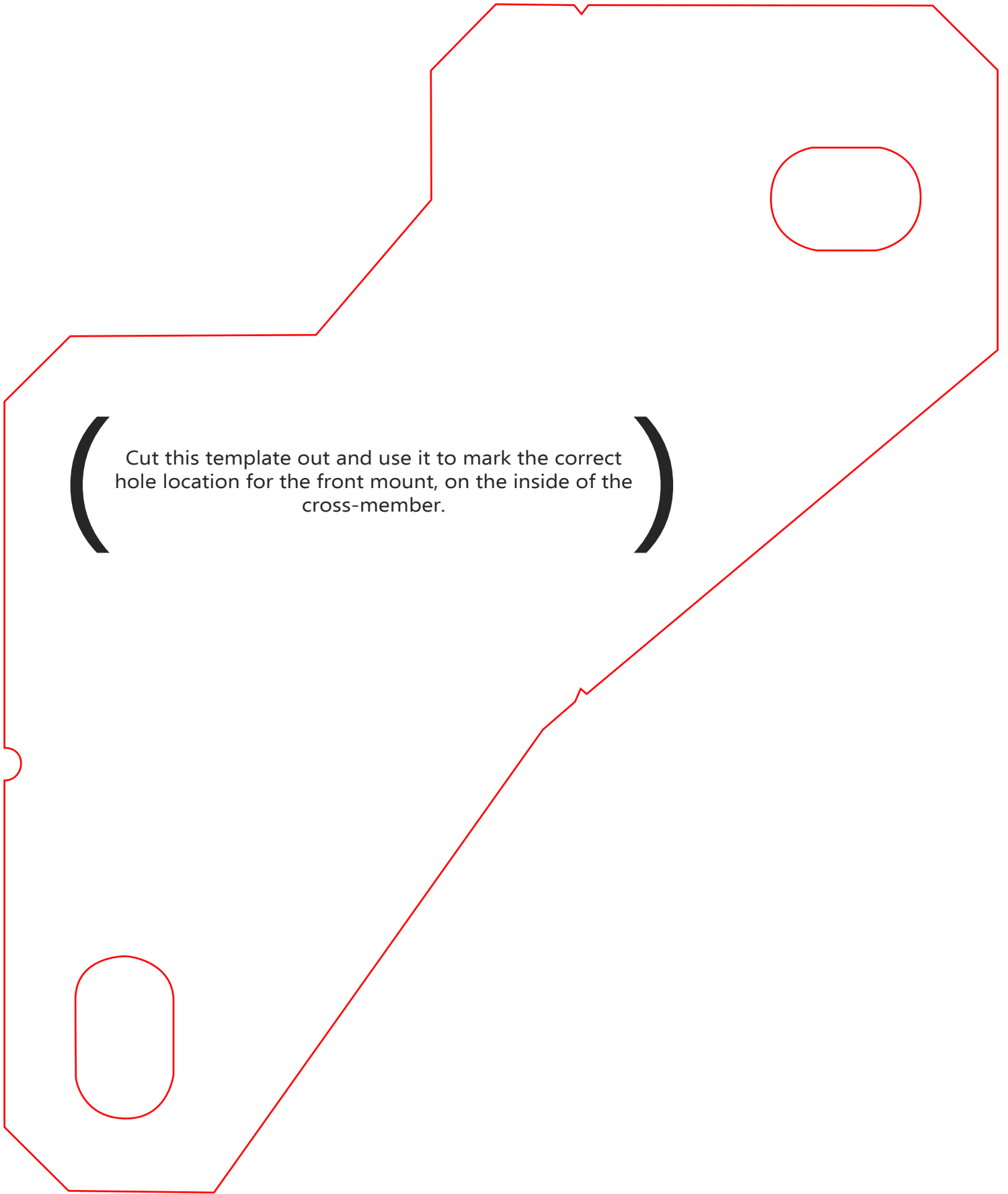

(Cut this template out and use it to mark the correct hole location for the front mount, on the inside of the cross-member.)

ITEM NO.	PART NUMBER	FINISH	DESCRIPTION	QTY.
1	4JRS1804-07	BS / BP	JL DESTROYER SLIDER WELDMENT - PASS	1
2	4JRS1804-08	BS / BP	JL DESTROYER SLIDER WELDMENT - DRIVER	1

FINISH CODE:
BS = BARE STEEL OPTION / BP = BLACK POWDER COAT OPTION

HARDWARE

ITEM NO.	PART NUMBER	FINISH	DESCRIPTION	QTY.
3	THN5013ZPGR5-02		TABBED HEX NUT 1/2-13 ZINC PLATE GR5	2
4	HB501372ZPGR5		HEX BOLT 1/2-13 X 4.50 HEX BOLT ZINC PLATE GR5	2
5	HN5013ZPGR5		HEX NUT 1/2-13 ZINC PLATE GR5	2
6	FW5022ZP		FLAT WASHER Ø1/2" X 1.375" ZINC PLATE	10
7	TR501316ZP		THREAD ROLLER 1/2-13 X 1.00 HEX ZINC PLATE	2
8	HB12150M25ZPCL88		HEX BOLT M12-1.50 X 25mm ZINC PLATE CL8.8	2
9	FW4318ZP		FLAT WASHER Ø7/16 X 1.25" ZINC PLATED	2
10	HB501316ZPGR5		HEX BOLT 1/2-13 X 1.00 HEX BOLT ZINC PLATE GR5	2

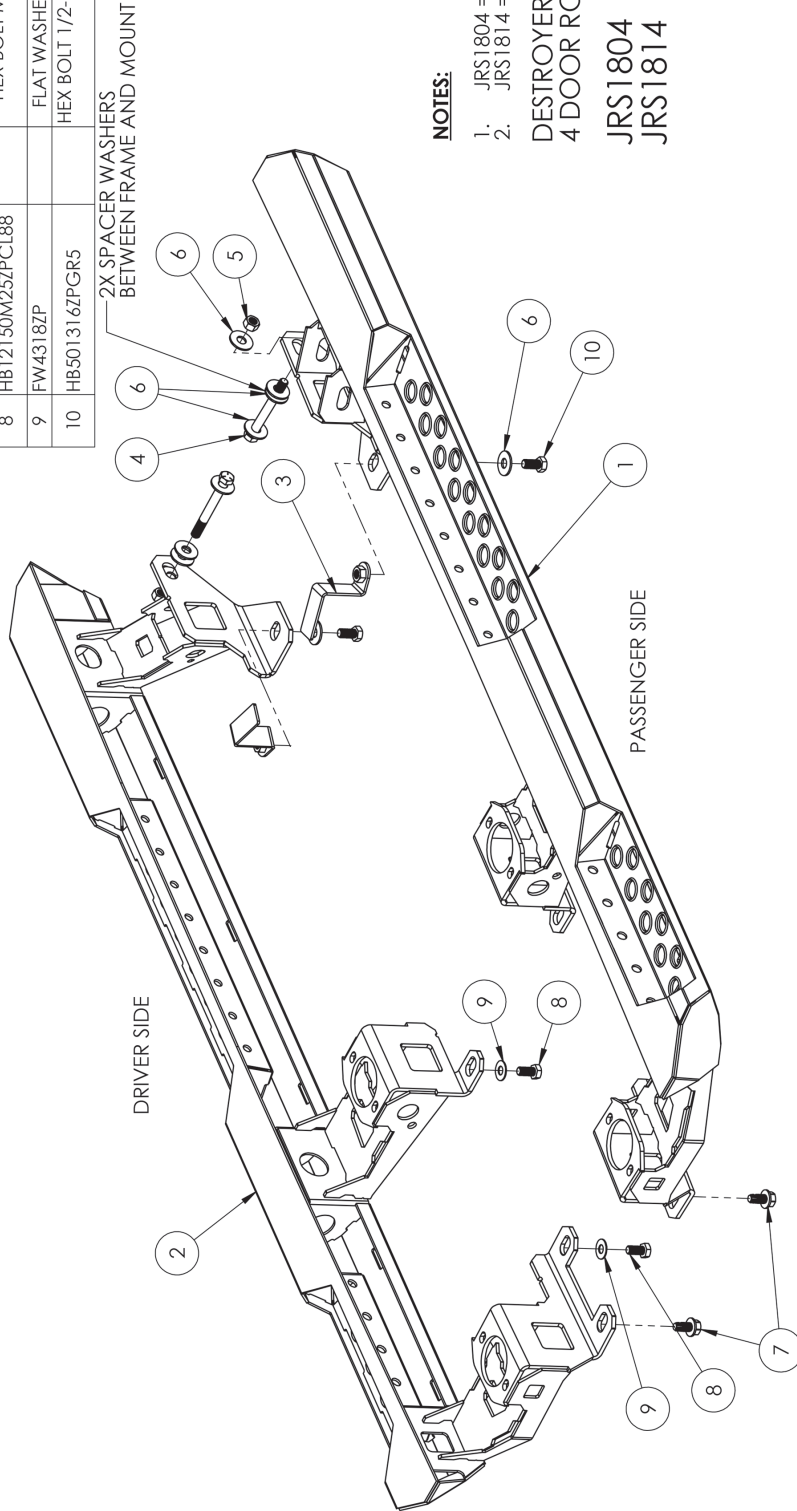

NOTES:

1. JRS1804 = BARE STEEL OPTION
 2. JRS1814 = BLACK POWDER COAT OPTION
- DESTROYER SERIES FRAME MOUNTED
4 DOOR ROCK SLIDERS

JRS1804
JRS1814



**JL Jeep 4 DOOR
Destroyer Series
Rock Sliders
Shipping Sheet**
Packaged by:

On:

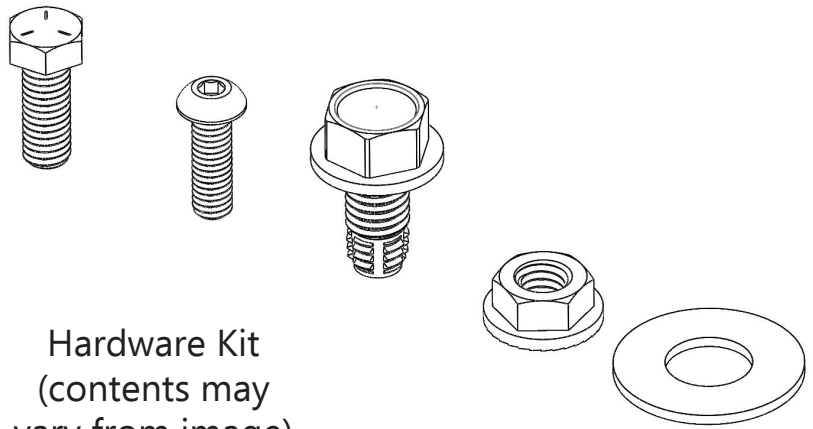

Hardware Kit
(contents may vary from image)

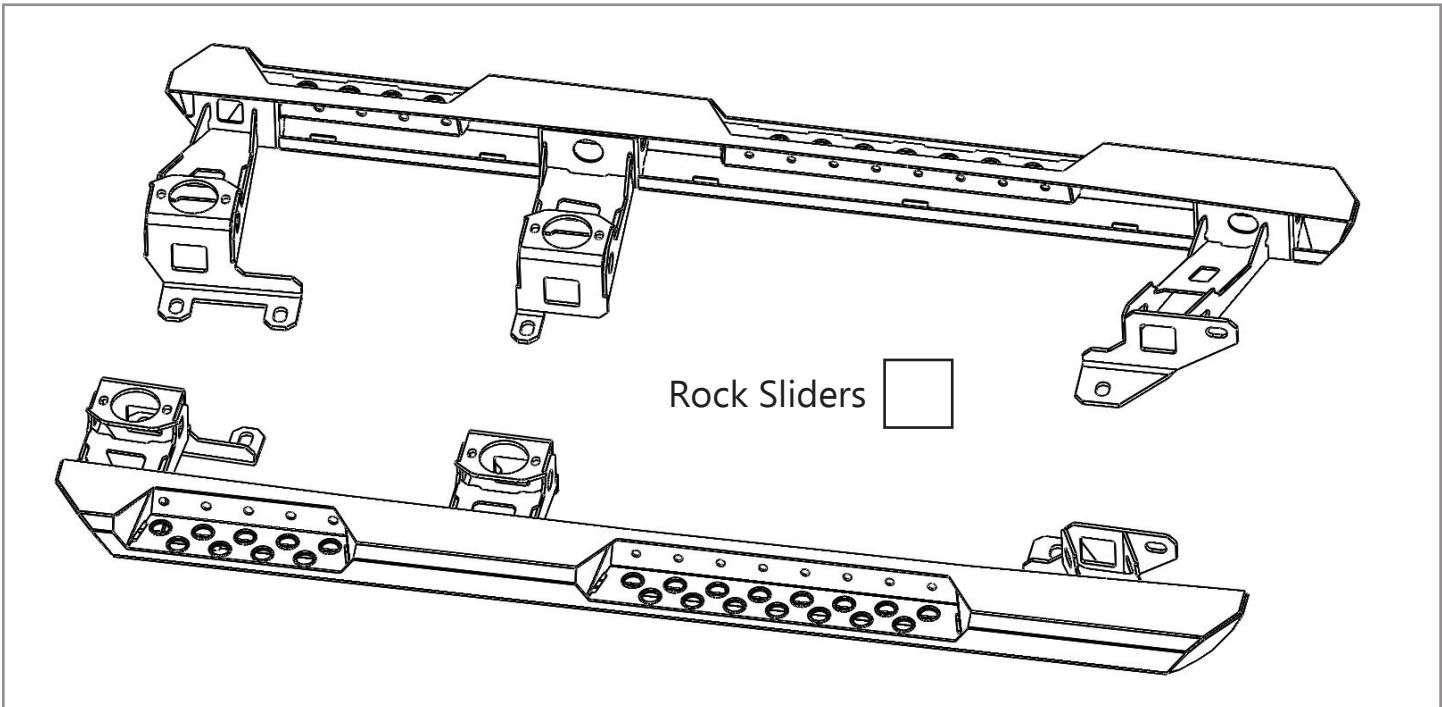

Rock Sliders



Install Instruction Booklet



**JL Jeep 4 DOOR
Destroyer Series**

Rock Sliders

Bolt Kit

Packaged by:

On: _____

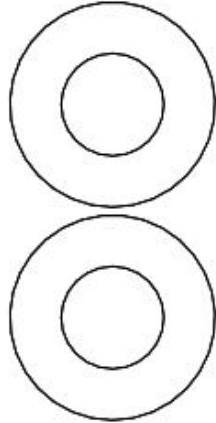
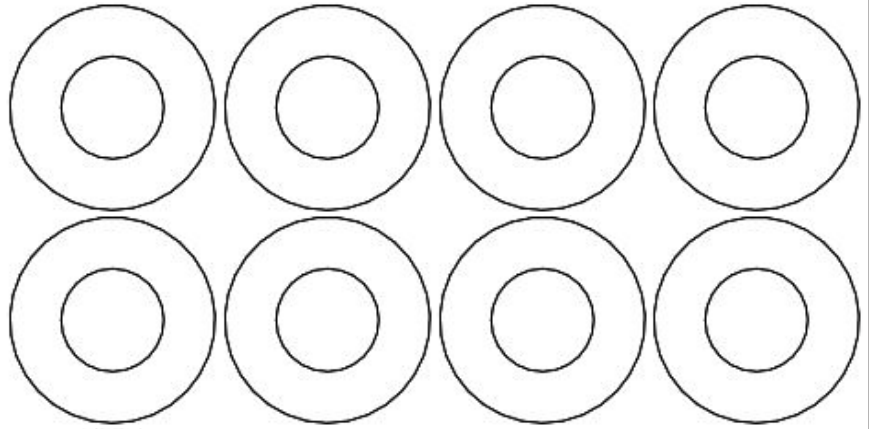

G **F**

1/2" x 1.375"
Washer
(x 10)

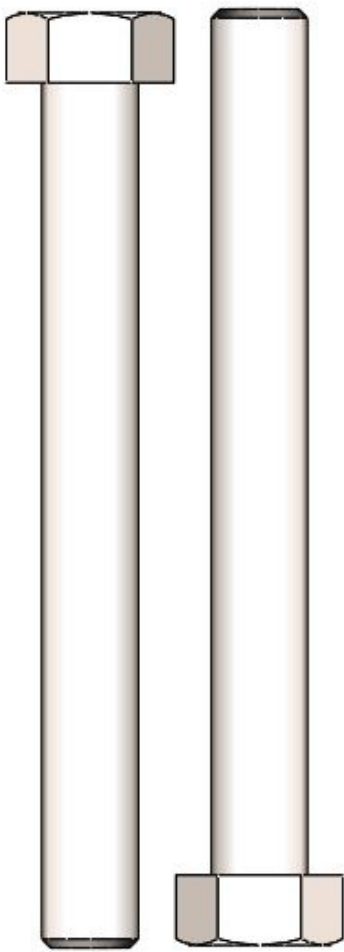



F **1/2" (13) x 4.5"**
Hex Bolt
(x 2)



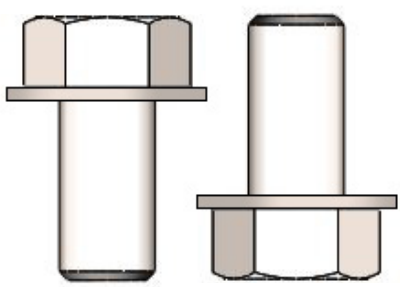

1/2" (13)
Hex Nut
(x 2)

F

B **1/2" (13) x 1"**
Self Tapping Thread
Roller
(x 2)

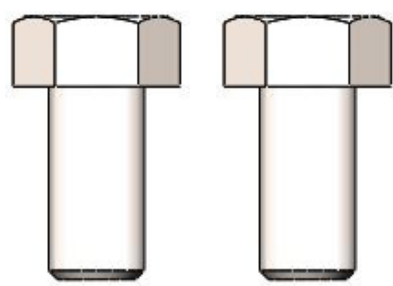
G **1/2-13 x 1"**
Hex Bolts
(x 2)

