

IMPORTANT NOTICE: Be sure to inspect and test fit product before having it coated or painted. Ranch Hand will not be responsible for the cost of the coating if any problems with fit or finish are not noted and addressed beforehand.

TOOLS REQUIRED

- Ratchet & Extension
- 7/16", 9/16", 5/8", 11/16" sockets and wrenches
- 13mm, 15mm, 18mm, 21mm sockets and wrenches
- 5/32" Allen wrench
- Cutting pliers
- Wire crimpers
- Butt Connectors
- Flat head and/or Phillips screwdriver



Please read through the entire set of instructions before continuing with installation to familiarize yourself with the process, save time, and make sure that you have all the corrects tools and parts needed to complete this installation.

DISASSEMBLY INSTRUCTIONS

1. Remove the license plate.
2. On some models there will be a sensor behind the license plate, you will need to unplug it.
3. Unplug and remove trailer plug.
4. Unplug the license plate/sensor wiring harness.
5. Remove the side bumper brackets.
6. Remove the four 18mm nuts of the bumper brackets.
7. Lastly, remove the two 13mm bolts that are located behind the license plate and remove bumper.

PREPPING AND INSTALLING THE MIDNIGHT BACK BUMPER

To prepare for installation, begin by laying out the included components. Please inspect all parts of your new Midnight product before installing. If any parts are missing or damaged, please contact Customer Service Team, customerservice@ranchhand.com, immediately before proceeding with installation.

1. Begin by unwrapping the bumper and checking that all part are accounted for.
2. Mount the license plate to the back plate using ¼" button head bolts and kep nuts.
3. From the back side of the bumper, install the trailer plug bracket. The round part of the bracket will be to the bottom. Use ¼" button head bolts and kep nuts to install.
4. Install the factory exhaust tips to the bumper. Use factory hardware to install.
5. Place the light bracket in position over the light insert. Secure both the light inserts and brackets to the bumper using the ¼" button head bolts and Kep nuts (7x per side).
6. Repeat this step for both the passenger and driver side of the bumper.
7. Mount the sensor (if present) and factory bracket to the sensor bracket provided. Then mount the bracket to the tabs located behind the license plate.
8. Install the Midnight bumper by using the 7/16" hardware provided.
9. Center from side to side and then tighten hardware. Open the bumper slowly to make sure there is clearance between the tailgate and bumper.
10. Cut the factory license plate wires. Strip wires and use butt connectors to install provided license plate lights.
11. Install the factory exhaust tips to the bumper. Use factory hardware to install.

FOR VEHICLES WITH SENSORS

1. If your vehicle has OEM parking sensors, carefully remove the sensors and harness from the OEM bumper.
2. Remove the “knock-out” plugs and install the grommets provided. Once grommets are in, apply WD-40 around the inside of the grommet to help guide the sensor into place without damaging it. Push the sensor through the grommet from the back side of the insert.
3. Secure the harness using tape or zip-ties.
4. If the vehicle was equipped with A.D.A.S. (Advanced Driver Assist System) remove them from the factory bumper. Mount the two sensor brackets to the mounting brackets of the bumper. You will need to drill the existing hole out to a ¼” and then mark and drill another hole in line with the second hole of the bracket. Mount the sensor to the sensor bracket and center over the hole and tighten screws



Back Bumper Installation Guide
2019+ CHEVY/GMC 1500

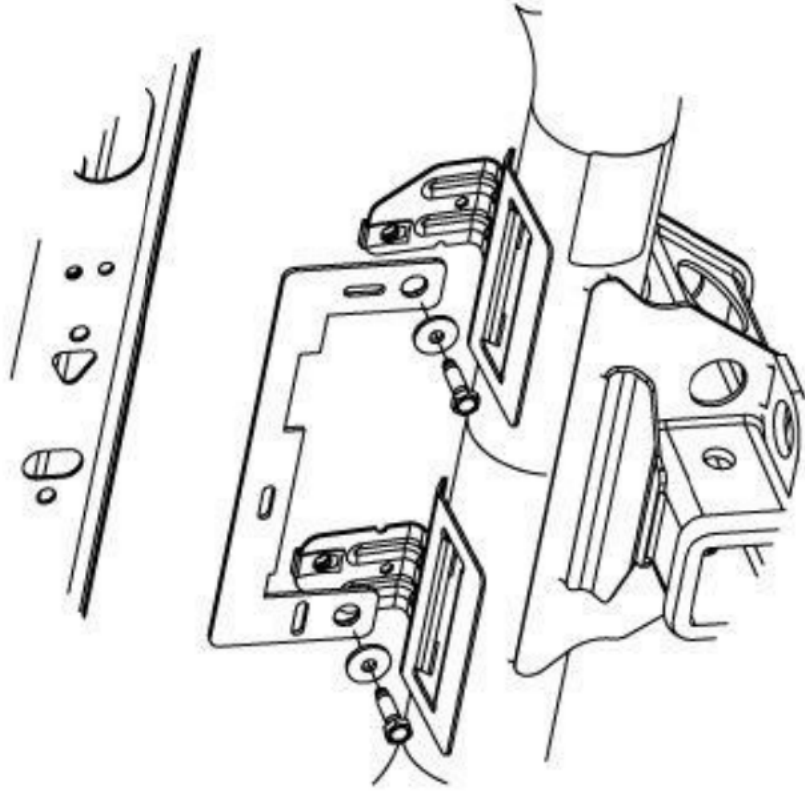
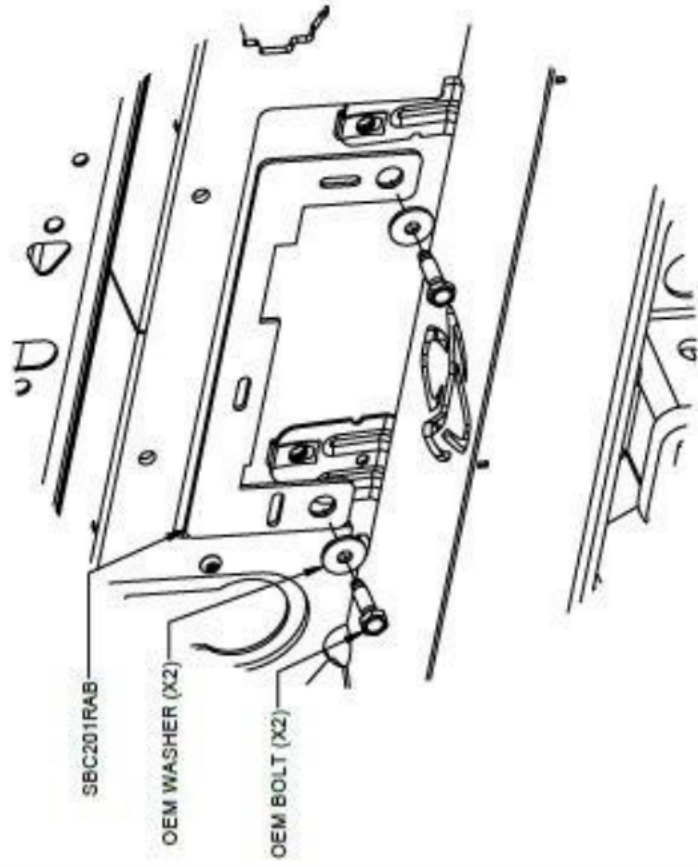



Back Bumper Installation Guide
2019+ CHEVY/GMC 1500

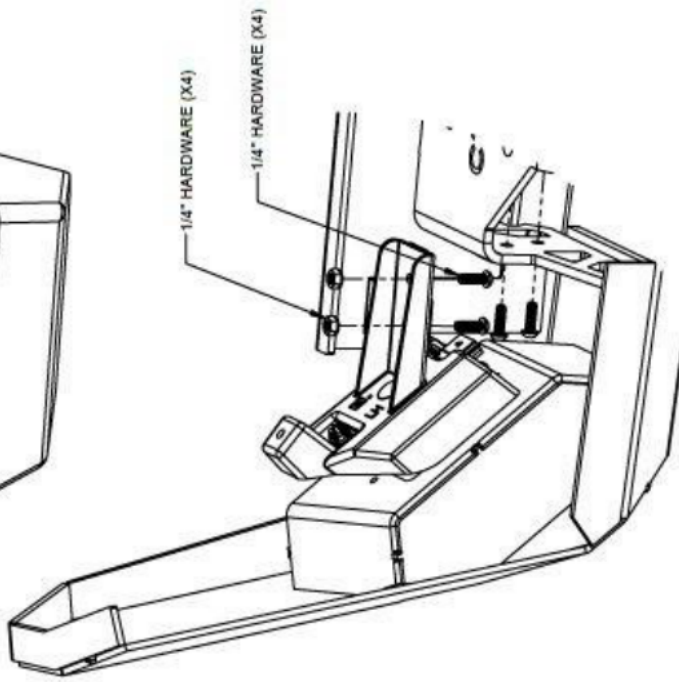
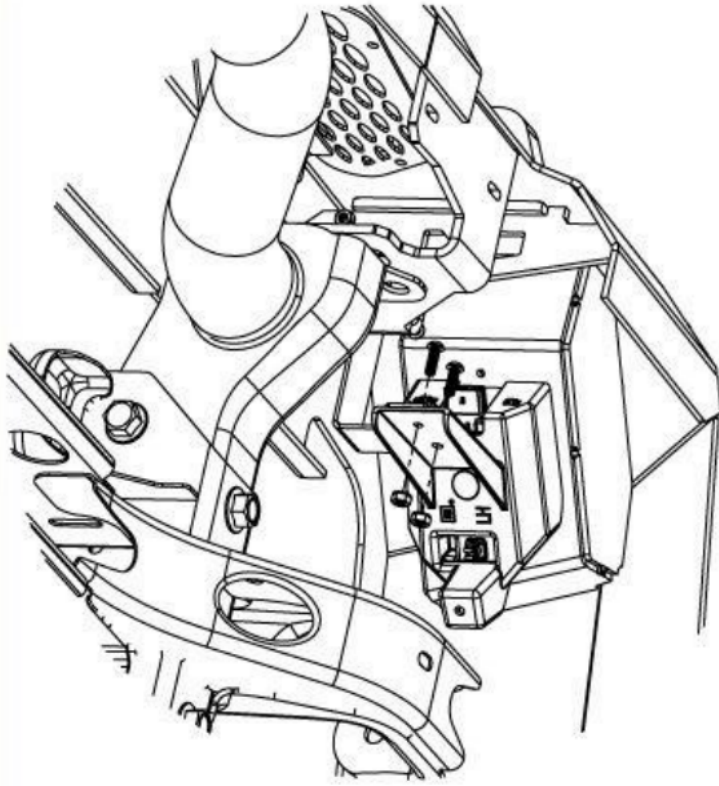
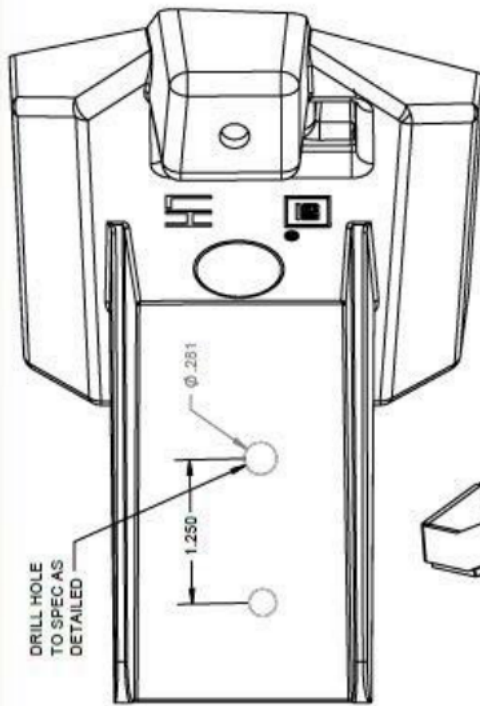



Back Bumper Installation Guide
2019+ CHEVY/GMC 1500

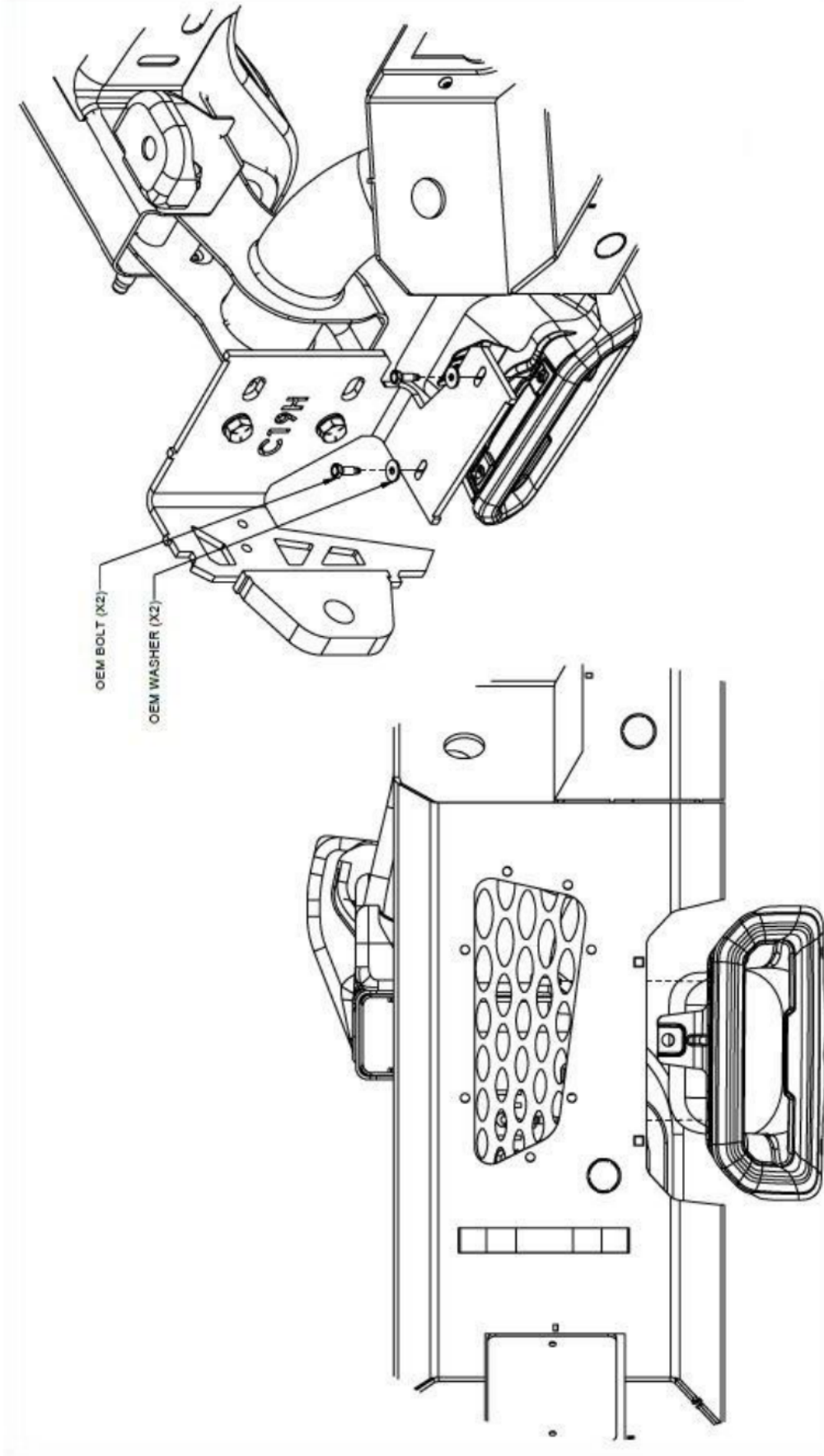



Back Bumper Installation Guide
2019+ CHEVY/GMC 1500

