



PART #P000015

Front Bumper for 18-20 Ford F150 with 20" double row LED light bar, no winch plate

PARTS LIST:

1	Front CS1 Overlay Bumper Assembly	8	12mm Lock Washers
1	Driver/Left Frame Mounting Bracket	4	12mm Hex Nuts
1	Passenger/Right Frame Mounting Bracket	2	10mm Double Bolt Plates (L-shaped bracket)
2	Lower Support Brackets	4	10mm x 20mm OD x 2mm Flat Washers
1	Driver/Left Mesh Plate	4	10mm Lock Washers
1	Passenger/Right Mesh Plate	4	10mm Hex Nuts
2	LED "L" Light Brackets	2	8-1.25mm x 25mm Hex Bolts
1	License Plate Relocation Bracket	2	8-1.25mm x 16mm Hex Bolts
2	Plastic Plugs for license plate mount	6	8mm x 24mm x 2mm Flat Washers
2	Bumper Edge Trim	4	8mm Lock Washers
4	Bracket Spacers	2	8mm Hex Nuts
4	12mm Plastic Retainers	12	6mm x 20mm Button Head Combo Bolts
2	12mm Wide Double Bolt Plates	2	6mm x 20mm Button Head Bolts
2	12mm Double Nut Plates	4	6mm x 18mm x 1.6 Flat Washers
4	12-1.75mm x 40mm Hex Bolts	2	6mm Nylon Lock Nuts
4	12mm x 32mm x 3mm Large Flat Washers	1	4mm Wrench
4	12mm x 24mm x 2.5mm STD Flat Washers	10	Nylon Wire Ties

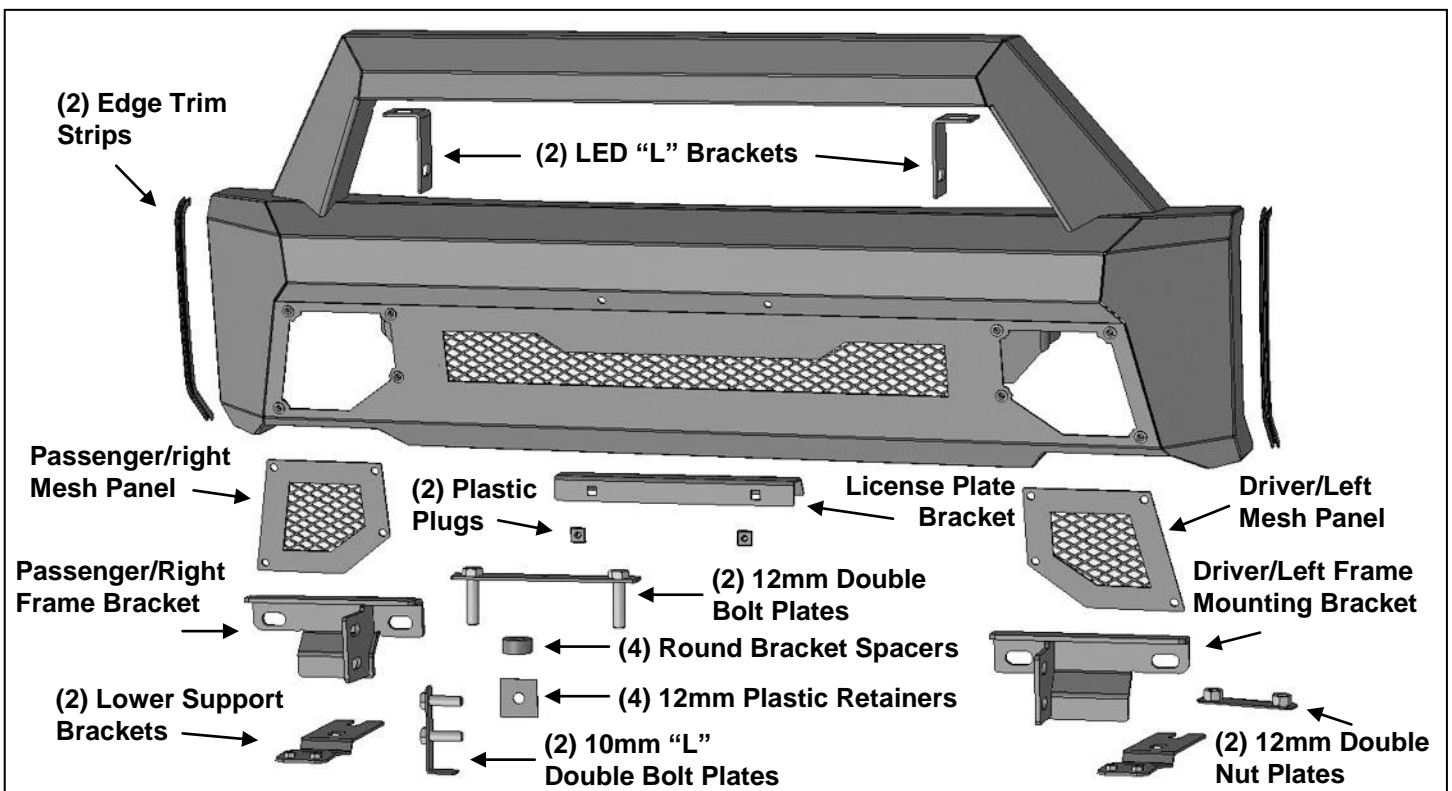

PROCEDURE:

REMOVE CONTENTS FROM BOX. VERIFY ALL PARTS ARE PRESENT. READ INSTRUCTIONS CAREFULLY BEFORE STARTING INSTALLATION. ASSISTANCE IS HIGHLY RECOMMENDED TO AVOID POSSIBLE INJURY OR DAMAGE TO THE VEHICLE. CUTTING MAY BE REQUIRED.

1. Remove the license plate and bracket. Next, remove the plastic bumper pads from the bumper, **(Figure 1)**. **NOTE:** Pull bumper pads straight out to release metal clips. Unplug and remove the adaptive cruise control sensor, if equipped.
2. Remove the (2) factory hex nuts attaching the driver/left side of the bumper to the end of the frame, **(Figure 2)**. Remove the factory double bolt plate from the back of the bumper. **NOTE:** Use a small flat blade screwdriver to pry up the metal clips to remove the bolt plate. Select the included longer Double Bolt Plate, **(Figure 3)**. Insert the Bolt Plate back through the bumper bracket and bumper, **(Figure 4)**. From the front, thread (2) 12mm Plastic Retainers onto the Bolt Plate to help hold it in place, **(Figure 5)**. Slide (2) Bracket Spacers onto the threaded bolts on the Bolt Plate, **(Figures 3 & 6)**.
3. Select the driver/left side Frame Bracket, **(Figure 7)**. Attach the Frame Bracket to the Bolt Plate with (2) 12mm x 24mm STD Flat Washers, (2) 12mm Lock Washers and (2) 12mm Hex Nuts, **(Figure 8)**. Do not fully tighten hardware at this time.
4. Repeat **Steps 2 & 3** to install the passenger/right Frame Bracket.
5. **Determine if vehicle is equipped with tow hooks to install lower Support Brackets.**

Models with tow hooks

- a. Remove the rubber seal around the tow hook. Remove the front bolt but only loosen the rear mounting bolt, **(Figure 9)**. Leave tow hook in place.
- b. Select (1) Support Bracket. Slide the Support Bracket between the tow hook and the bottom of the frame, **(Figures 13 & 14)**. Reinstall the front factory tow hook bolt. Do not fully tighten hardware at this time. **NOTE:** Cut the rubber seal to reinstall over Bracket.
- a. Repeat the previous Steps to install the passenger/right Support Bracket.

Models without tow hooks.

- b. Select the included (1) 12mm Double Nut Plate. Apply a short piece of tape, (duct or masking tape for example) to the end of the Nut Plate to act as a temporary handle, **(Figure 10)**. Slide the Nut Plate into the open end of the frame and over the holes in the bottom of the frame, **(Figure 11)**. Thread (1) 12mm x 40mm Hex Bolt, (1) 12mm Lock Washer and (1) 12mm x 32mm Large Flat Washer into the rear mounting hole to hold the Nut Plate in the correct position. **NOTE:** On some models, it may be necessary to loosen or remove the large hex nuts, (1 per side), attaching the back of the bumper to the bottom of the bumper bracket. Tilt the bumper forward for more room to insert the Double Nut Plates into the frame, **(Figure 11 & 13)**.
 - c. Select (1) Support Bracket. Use a sharp knife or hacksaw blade to cut a slot out of the lower plastic cover to clear the Support Bracket, **(Figure 12)**. Remove the plastic cover from the bottom of the bumper if necessary. Reinstall after cutting slots.
 - d. Slide the Support Bracket through the opening and under the previously hardware Hex Bolt. Attach the front of the Support Bracket to the bottom of the frame and Double Nut Plate with the included (1) 12mm x 40mm Hex Bolt, (1) 12mm Lock Washer and (1) 12mm x 32mm Large Flat Washer, **(Figures 13 & 14)**. Do not tighten.
 - e. Repeat the previous Steps to install the passenger/right Support Bracket.
6. Carefully unwrap the Bumper. Attach the included Edge Trim to both ends of the Bumper, **(Figure 15)**.
 7. On vehicles requiring front license plate, select the License Plate Bracket. Attach the Bracket to the front of the Bumper with the included (2) 6mm x 20mm Button Head Bolts, (4) 6mm Flat Washers and (2) 6mm Nylon Lock Nuts, **(Figure 16)**. Push the included (2) push-in Plastic Plugs into the square holes in the Bracket. Reuse the factory hardware to attach the license plate to the Plastic Plugs.
 8. With assistance, position the mounting tabs on the back of the Bumper up to the inside of the Frame Brackets. Temporarily support Bumper. **WARNING:** To avoid possible injury or damage to the vehicle, do not proceed until the bumper is fully and safely supported.

9. Select (1) "L" Double Bolt Plate, (**Figure 17**). Insert the Bolt Plate through the outer opening in the Bumper. Guide the Bolt Plate into, up and through the back of the Brackets. Attach the Bumper to the Bolt Plate with (2) 12mm Flat Washers, (2) 12mm Lock Washers and (2) 12mm Hex Nuts, (**Figures 18 & 19**). Do not tighten hardware. Repeat this **Step** to attach the passenger/right side of the Bumper to the Mounting Bracket.
10. Line up the mounting holes in the driver/left Support Bracket with the holes in the bottom of the Bumper. Attach the Support Bracket to the inside of the Bumper with the included (2) 6mm Button Head Combo Bolts, (**Figures 18 & 20**). Do not fully tighten hardware. Repeat this Step to attach the passenger/right Support Bracket.
11. Check the Bumper for level and centered on the vehicle. Adjust the Bumper as necessary and fully tighten all Mounting Bracket hardware. **NOTE:** If additional left-right adjustment is required, temporarily loosen the Frame Bracket hardware and slide the Brackets left or right as necessary and fully tighten Frame Bracket hardware.
12. Once hardware has been fully tightened, attach Mesh Fill Panels to Bumper with the included (8) 6mm x 20mm Button Head Combo Bolts, (**Figure 21**)
13. Top mounted LED light installation (optional-light not included).
 - a. Select (1) LED "L" Light Bracket. Attach the Bracket to the bottom of the top hoop with (1) 8mm x 25mm Hex Bolt, (2) 8mm Flat Washers, (1) 8mm Lock Washer and (1) 8mm Hex Nut, (**Figure 22**). Do not tighten hardware at this time.
 - b. Repeat previous Step to attach the passenger/right Bracket.
 - c. Attach light to Top Brackets with the hardware included with the light or the included (2) 8mm x 16mm Hex Bolts, (2) 8mm Lock Washers and (2) 8mm Flat Washers. Adjust the width of the Brackets to the light. **IMPORTANT:** Top Light Brackets are designed to install most 20" to 24" single and double row bar style LED lights.
 - d. "L" Brackets installed to the inside will accommodate a light 21-3/8" to 23-3/16" wide.
 - e. "L" Brackets installed to the outside will accommodate a light 24-9/16" to 26-5/16" wide.
 - f. Fully tighten top light hardware once adjusted.
14. Do periodic inspections to the installation to make sure that all hardware is secure and tight.

To protect your investment, Do not use any type of polish or wax that may contain abrasives that could damage the finish. Mild soap may be used to clean the Front Bumper assembly.

Driver/left Side Installation Pictured

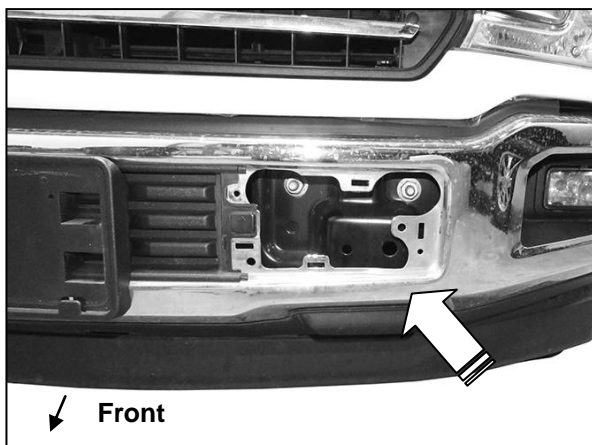

(Fig 1) Remove license plate. Pull plastic bumper pad straight out to release from clips.

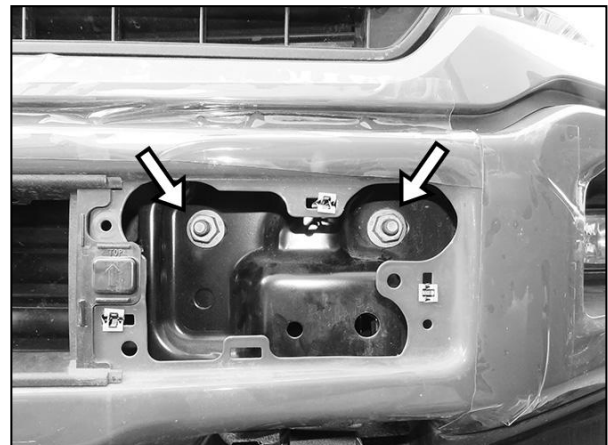

(Fig 2) Remove (2) factory hex nuts (arrows) and remove bolt plate from behind bumper

Driver/left Side Installation Pictured

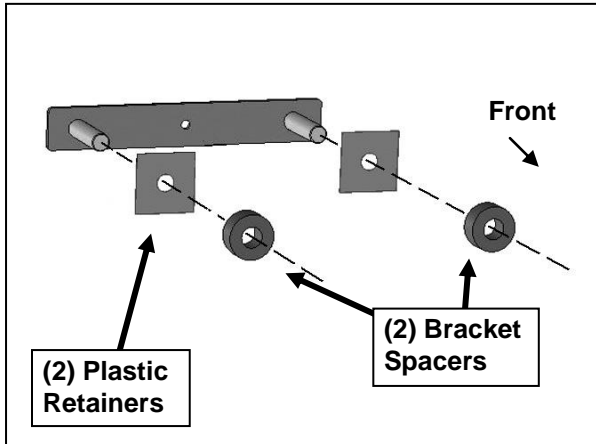

(Fig 3) Insert Double Bolt Plate back through bumper. Thread (2) Plastic Retainers onto Bolt Plate to hold in place. Slide Bracket Spacers onto threaded end of Bolt Plate

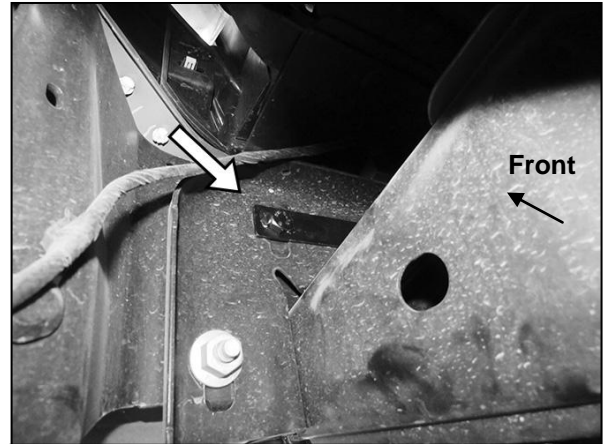

(Fig 4) Driver/left Double Bolt Plate installed (pictured from back of bumper)

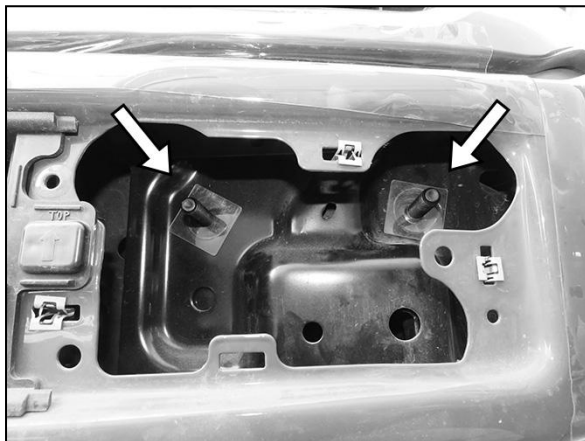

(Fig 5) Thread (2) Plastic Retainers onto Bolt Plate to hold in place (arrows)

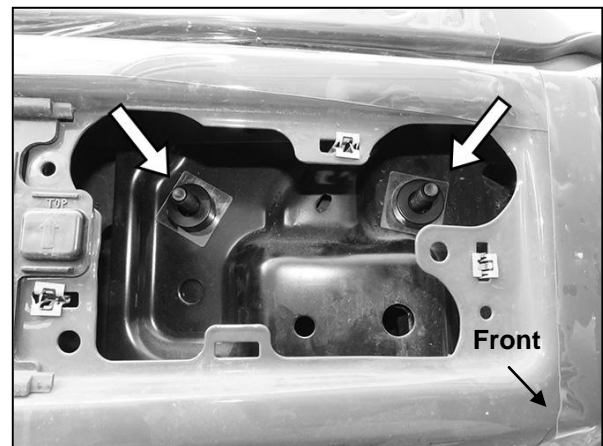

(Fig 6) Slide (2) Bracket Spacers onto threaded end of Bolt Plate (arrows)

Driver/left Side Installation Pictured

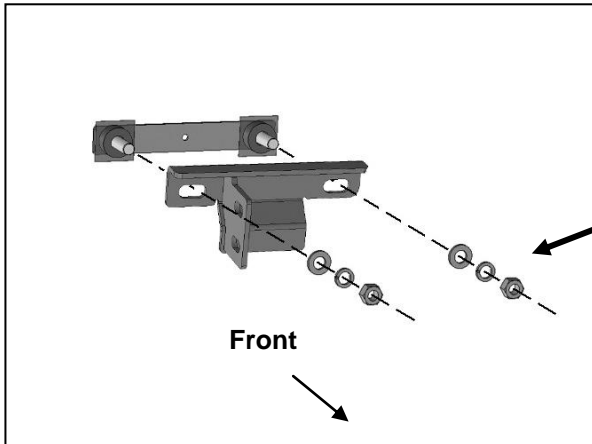

- (2) 12mm x 24mm STD Flat Washers
- (2) 12mm Lock Washers
- (2) 12mm Hex Nuts

(Fig 7) Attach driver/left Frame Bracket over Spacers to Double Bolt Plate

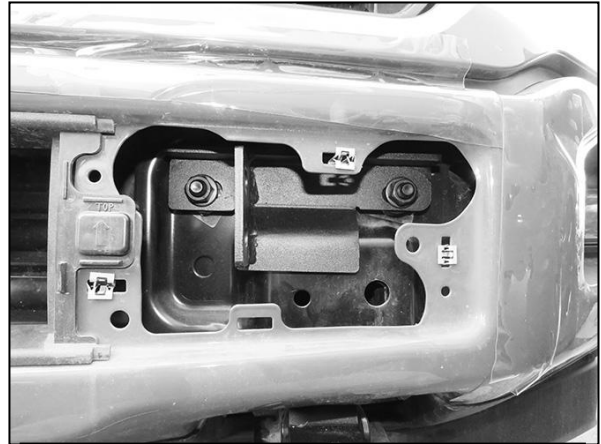

(Fig 8) Driver/left Frame Bracket installed



(Fig 9) Models with tow hooks, remove forward bolt and loosen but do not remove rear bolt to hold factory double nut plate in place in frame

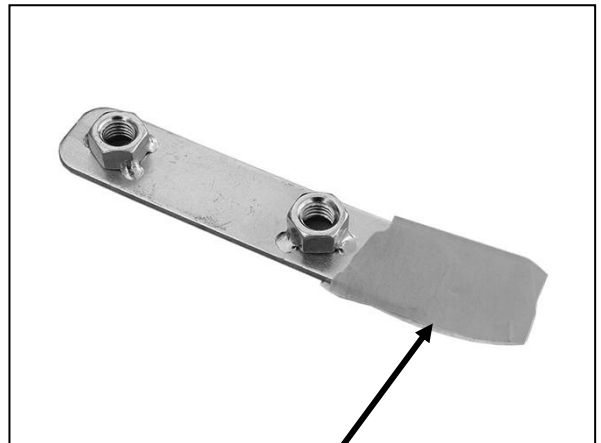

(Fig 10) If necessary, apply tape (masking, duct tape for example) to extend the reach to line up the Double Nut Plate with holes in the frame

Driver/left Side Installation Pictured



(Fig 11) Models without tow hooks, remove bottom hex nuts attaching bumper to bracket (Fig 4). Loosen the front hex nuts and tilt the bottom of the bumper out enough to insert the Double Nut Plates into the end of the frame (arrow).



(Fig 12) Models without tow hooks, Cut slot through plastic splash guard to clear Support Bracket

Models without tow hooks
 (2) 12mm x 40mm Hex Bolts
 (2) 12mm Lock Washers
 (2) 12mm x 32mm Large Flat Washers

**Double Nut Plate
 (in frame)**

Models with tow hooks,
 reuse factory hex bolts or:
 (2) 12mm x 40mm Hex Bolts
 (2) 12mm Lock Washers
 (2) 12mm x 32mm Large Flat Washers

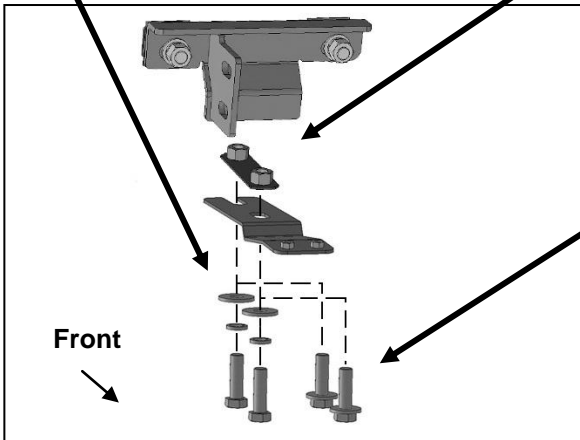

(Fig 13) Attach Support Bracket to Double Nut Plate in frame

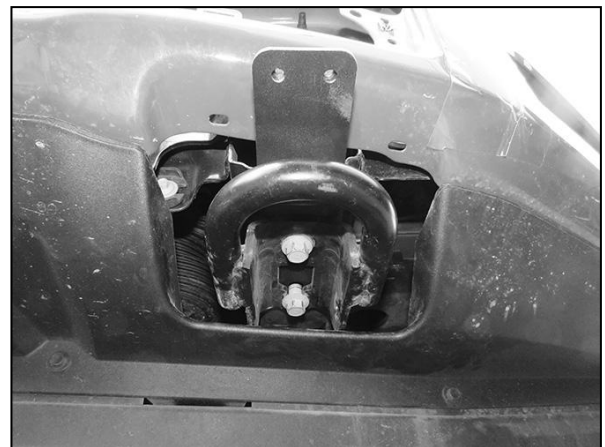

(Fig 14) Support Bracket installed between tow hook and bottom of frame

Driver/left Side Installation Pictured

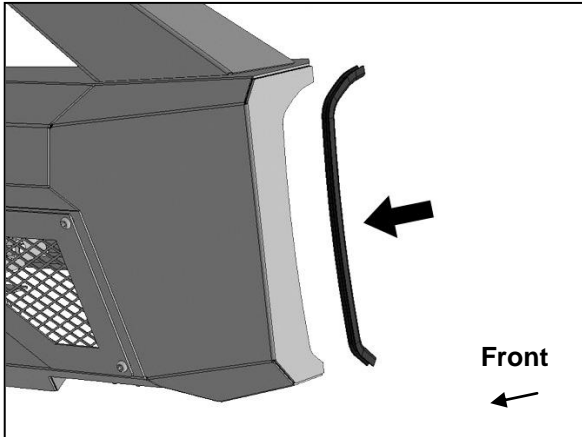

(Fig 15) Push Edge Trim onto both ends of Bumper

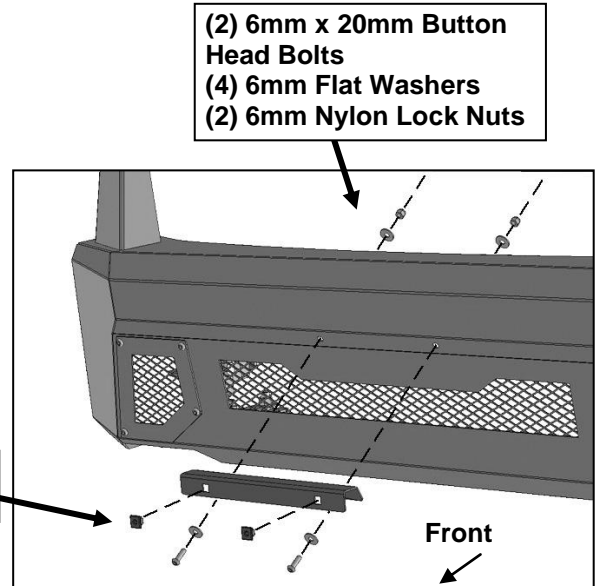

(2) 6mm x 20mm Button Head Bolts
(4) 6mm Flat Washers
(2) 6mm Nylon Lock Nuts

(2) Plastic Plugs

(Fig 16) Attach Support Bracket to top of Bracket Assembly and factory tow hook (if equipped)

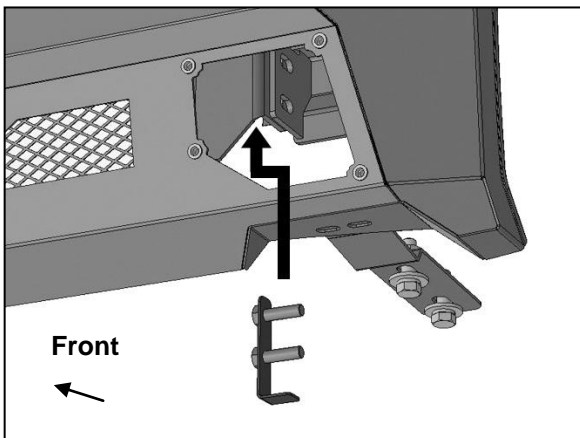

(Fig 17) Insert Double Bolt up and through back of tab on Bumper and Frame Bracket

(2) 10mm Flat Washers
(2) 10mm Lock Washers
(2) 10mm Hex Nuts

(2) 6mm x 20mm Combo Bolts

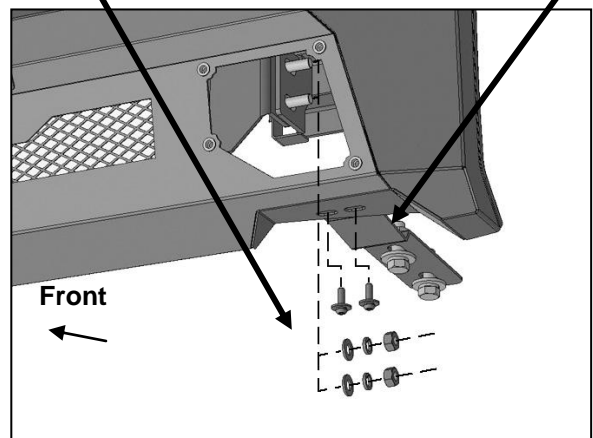

(Fig 18) Attach driver/left side of Bumper to Double Bolt Plate. Attach bottom of Bumper to Support Bracket

Driver/left Side Installation Pictured



(Fig 19) Driver/left side of Bumper attached to "L" Double Bolt Plate and Bracket



(Fig 20) Driver/left Support Bracket attached to inside of Bumper (model with tow hook)

(4) 6mm Button Head Combo Bolts

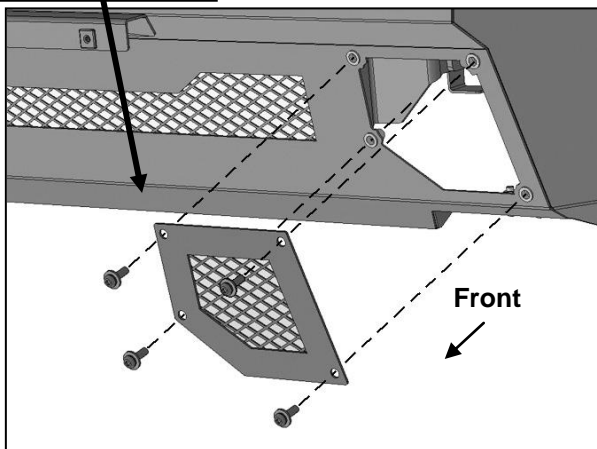

(Fig 21) Attach driver/left Mesh Panel after Bumper has been adjusted and hardware fully tightened

**8mm x 16mm Hex Bolt
8mm Lock Washer
8mm Flat Washer**

**8mm x 25mm Hex Bolt
(2) 8mm Flat Washers
8mm Lock Washer
8mm Hex Nut**

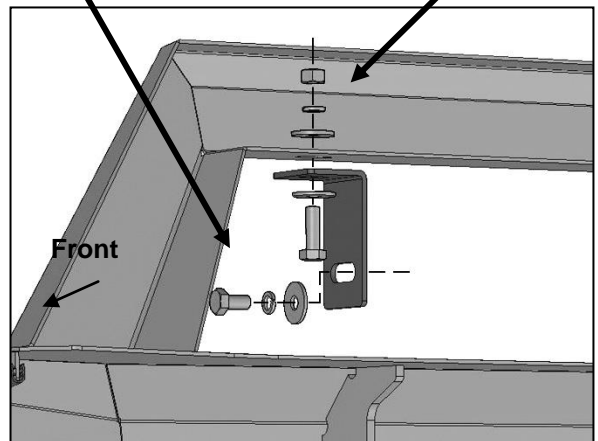

(Fig 22) Attach LED "L" Brackets to bottom of loop. NOTE: Top Light bracket mounting location is designed for 20-24" single or double row bar style light. Flip Brackets around if necessary