



WINCH MOUNT

2016-23 TOYOTA TACOMA



INSTALL GUIDE

EXP235

PLEASE READ ENTIRE GUIDE BEFORE INSTALLATION

Recommended that you read this entire install guide before installation. Check that all hardware is present before starting or scheduling an install. This guide is supplemental to mechanical knowledge and ability. Anyone not familiar with automotive installation should seek professional installation.



INSTALL GUIDE

IMPORTANT INFO/FAQ

INSTALL GUIDE

ALL

INSTALLATION HELP

Please review terms and conditions for details

Recommended purchaser review Welcome Guide at time of purchase for details

Care and Maintenance available at www.exp-one.com/resources

We do our best to offer timely assistance with your installation questions however as most of our team members are primarily engaged in the manufacturing process and packaging processes, we do not currently offer a tech for on-demand calls and inquiries. For the more technical installs or installs that are time-sensitive in nature, we would recommend our customers seek out the services of professional shops with experience specific to aftermarket bumpers that can better meet your needs. We are happy to make recommendations to you on shops familiar with our products in your area. We do our best to respond to installation questions within 24-48 hours of contact as much as possible. Long-distance problem assessment can be difficult, so photos and videos are often required for us to best assist you. We highly recommend your initial contact regarding installation questions include both close-up and full photos, detailed descriptions using our part descriptions as much as possible, and video. This enables us to better assist without having the ability to see the install difficulties directly and assist you as quickly as possible.

NOTE

Expedition One does not guarantee fitment with other aftermarket products, or reinstallation of take off OEM parts.

Expedition One is NOT RESPONSIBLE for damage to paint or powder coating, items assembled in error during installation or costs associated with install

OEM manufacture model refreshes/updates, factory build location and suppliers may cause variations in fitment or installation and can not be verified, vehicle to vehicle .

This product contains chemicals known to the state of California to cause birth defects or other reproductive harm. For more information go to www.p65warnings.gov

GSA# GS-30F-013CA

EXPEDITION ONE
113 N. 700 W. BUILDING 5C BAY 1
OGDEN, UT 84404
INFO@EXPEDITIONONE.BIZ
801-627-2921

This product contains chemicals known to the state of California to cause birth defects or other reproductive harm. For more information go to www.p65warnings.gov

INSTALL GUIDE

ALL

WINCHES

We use the most common bolt patterning but cannot guarantee your particular winch will fit. Because there are so many different brands on the market for winches, we typically recommend you wait until you have your bumper in-hand and ideally even installed to have specific measurements for best fit for your particular application. Integrated and Non-Integrated solenoid fitment varies by vehicle, model, and engine. Non-integrated solenoids will need to be relocated to an open location with in the bumper, engine bay, or other open location. We DO NOT provide mounts or instruction for relocation of the solenoid. Most bumpers use a foot forward mount and will require the winch to be clocked (see winch manufacture for details). Winch plates or direct mounting locations will be provided with the bumper, see install guide for details. See winch manufacture for hardware, associated parts, or fairleads. . We DO NOT manufacture the winch, provided wiring, or instructions on how to connect to the vehicles power.

AFTERMARKET or OEM PRODUCTS

We DO NOT guarantee fitment or installation of any aftermarket, third party or OEM parts, accessories, or hardware. This includes items such as lighting, winches, skids, lifts, suspension, and accessory mounts. Access to all brands, manufactures and country of origin specific parts is limited or impossible during the product development stage and subsequent new or modified revisions of said products including OEM design changes or refreshes. It is recommended you have the product in hand and installed before modifying with other aftermarket parts. Consult forums or other sources to gain any first hand knowledge of other products others have installed.













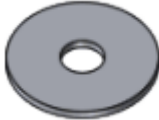

INSTALL GUIDE

ALL

HARDWARE

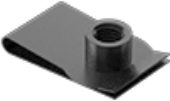
Please review for details and installation. Figures or data may vary. Leave all accessible hardware loose for installation and tighten all hardware after everything is installed on the vehicle. Check and retighten all hardware after the first 100 miles and/or after off roading. **Some hardware locations do not require being tightened to spec due to there design, location or material attachment (including rubber, plastic, and aluminum). Over tightening may break or damage parts. Torque spec may vary, amounts listed are generic.**

HARDWARE		TORQUE SPEC – FT.-LBS.	
SIZE	SOCKET WRENCH	GRADE 5 M- 8.8	GRADE 8 M – 10.9
#8	1/4"	X	
#10	5/16"		
1/4"	7/16"	6-8	9-10
5/16"	1/2"	13-14	18-20
3/8"	9/16"	23-26	33-37
7/16"	5/8"	37-41	52-58
1/2"	3/4"	57-64	80-90
9/16"	13/16"	82-91	115-129
5/8"	15/16"	112-118	159-180
3/4"	1-1/8"	200-223	282-315
7/8"	1-5/16"	322-355	454-501
1"	36MM	X	
M6	10MM	9-10	13-15
M8	13MM	22-24	32-35
M10	15MM	44-49	64-72
M12	18MM	76-83	112-123

TYPES OF HARDWARE		
		
HEX CAP BOLT	WASHER	NYLOC NUT
		
BUTTON HEAD BOLT	FENDER WASHER	HEX NUT
		
CARRIAGE BOLT	INTERNAL TOOTH	JAM NUT
		
SOCKET CAP BOLT	CLIP NUT	ACORN NUT
		
FLAT HEAD SCREW	RIVET NUT	COUPLING



GRADE5

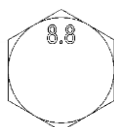

CLASS8.8

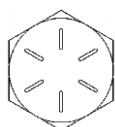

GRADE8



CLASS10.9

NOTE - Extra hardware may be left over due to model or option specific items that may not be required for the install.

INSTALL GUIDE

EXP235

A Winch Mount	1
B Internal Mount	1
C Front Reinforcement Brackets	2
Front Mounting Hardware	
5/16" -18 X 3/4" Hex Cap Bolt	1
5/16" -18 Nyloc Nut	1
5/16" SAE Washer	2
3/8" -16 x 1" Button Head Bolt	3
3/8" -16 X 1 1/4" Hex Cap Bolt	8
3/8" -16 Clip Nut	8
3/8" -16 Nyloc Nut	3
3/8" USS Washer	11
1/2" -1 X 1 1/4" Hex Cap Bolt	2
1/2" -1 X 4" Hex Cap Bolt	4
1/2" USS Washer	12
1/2" -13 Nyloc Nut	6

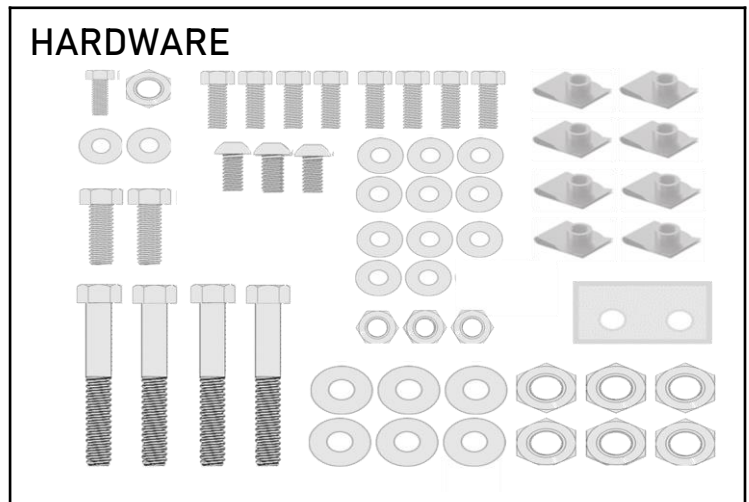
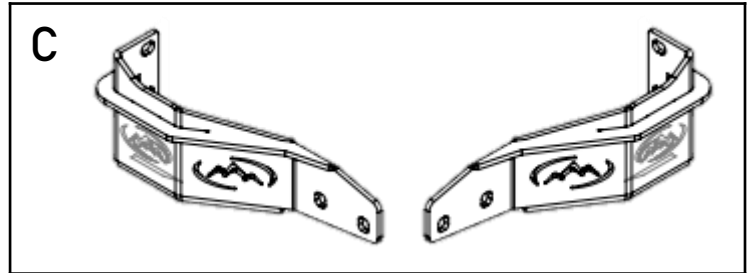
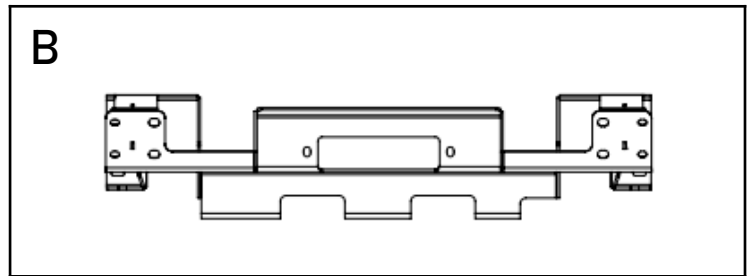
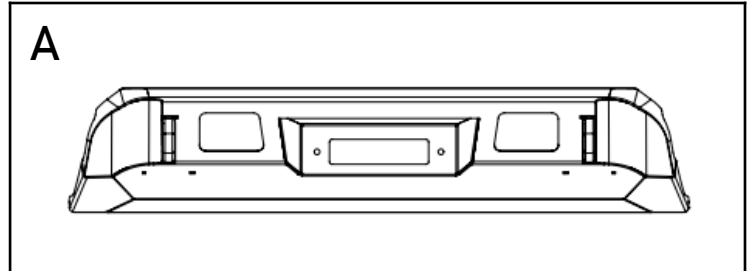

1 - REMOVE GRILL

Remove the 2 bolts and clips holding the top section of the grille. Release the bottom clips and remove the grille. Disconnect any wiring as this may vary on certain models.



2 - REMOVE THE BUMPER

Unbolt the underside section of hardware of the bumper. Remove the additional plastic pins and bolts around the frame. Disconnect all wiring and remove the front bumper.



3- HOSE RELOCATION BRACKET

Install the hose relocation bracket on the top of the passenger side frame rail just above where the frame reinforcement bracket is located. Be sure to orient the bracket so that the hose will be moved as far away from the frame as possible.. Remove the frame plugs for mounting the brackets.

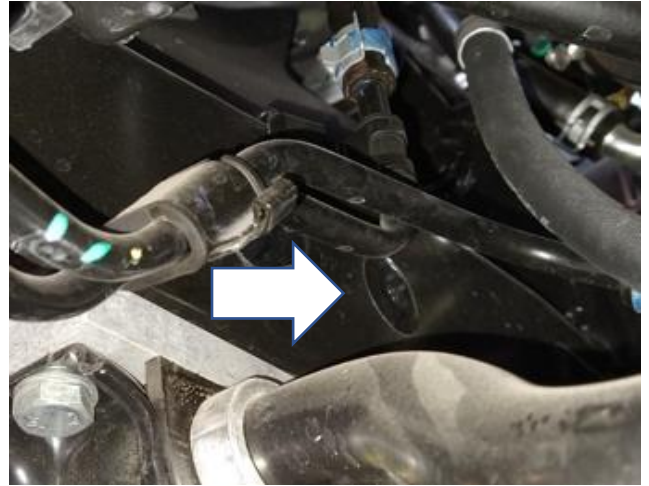

4 - FRAME LOCATION

Remove the OEM hardware located on the frame mount for installing the winch mount internal frame. Recommended that the winch be mounted and installed to the internal frame before continued installation.

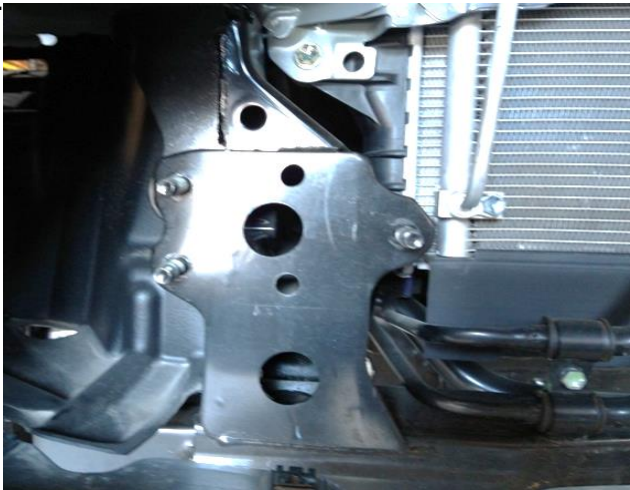

5 – BRACKET MOUNTING

Attach the frame mounts as shown and mount using the provided 1/2" and OEM hardware

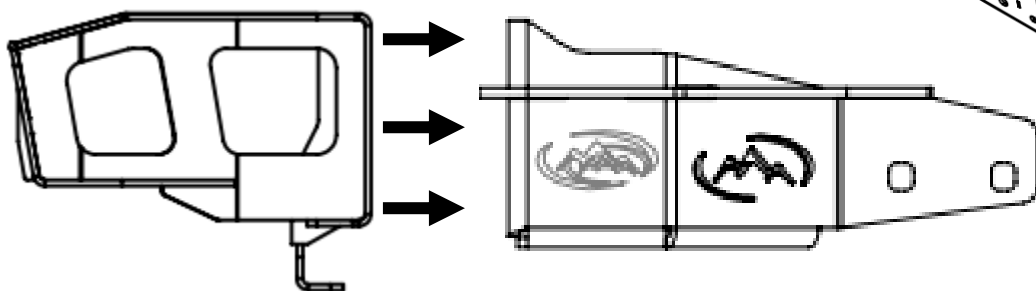
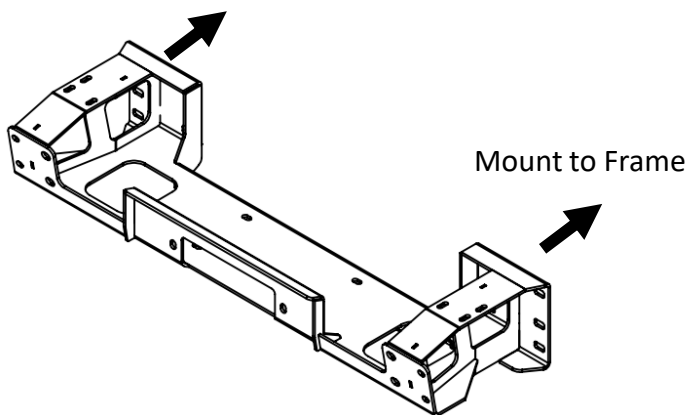
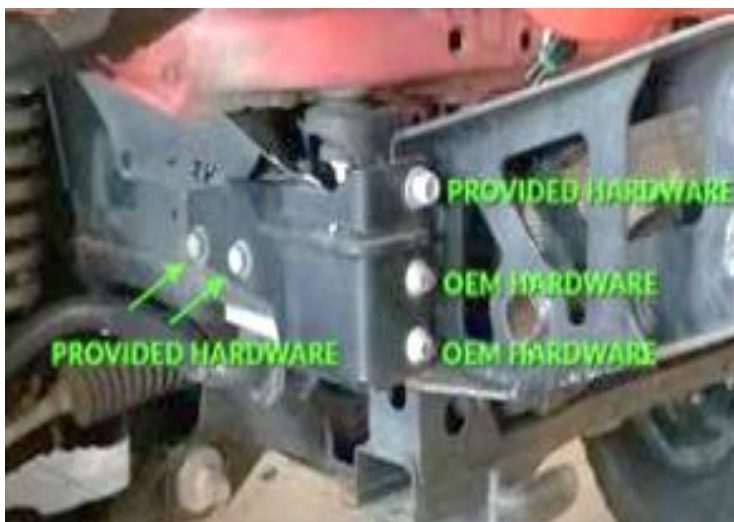

Bracket should fit over the outside of the internal frame

6 – OEM BUMPER INSTALLATION

Before remounting the OEM bumper, the fake skid plate area and the lower plastic air dam (if equipped) will need to be removed. The skid plate is held in by clips and hardware. If trimming is needed, start small and cut tiny sections. Mount to the vehicle as to gauge the need to cut more



Once complete reinstall the OEM Bumper

7 - WINCH MOUNT INSTALLATION

Use the provided 3/8" clip nuts to attach the cover to the vehicle and internal mount using the provided 3/8" hex cap bolts. Leave hardware loose for adjustment and alignment of the mounts before tightening. Repeat for each side.

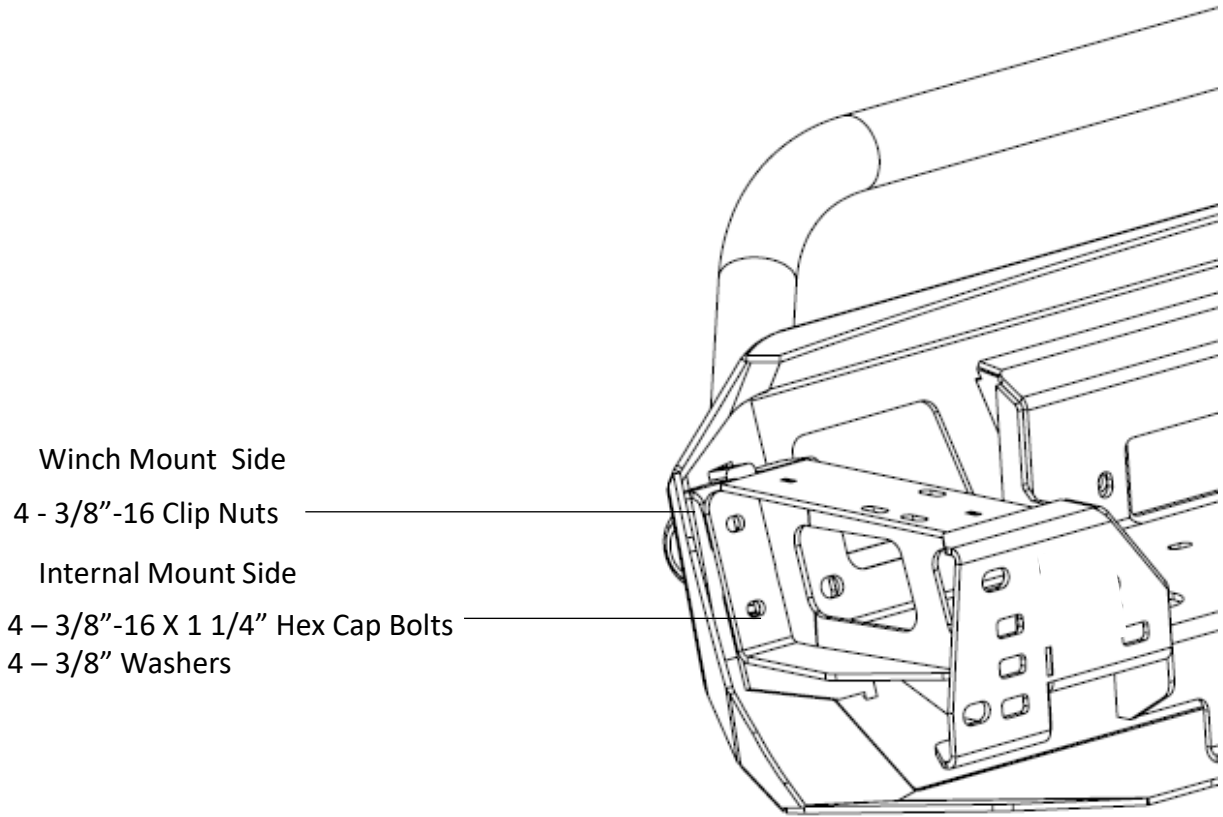

Attach the cover and internal mount at the bottom using the provided 3/8" button head bolts and washers/nyloc nuts.

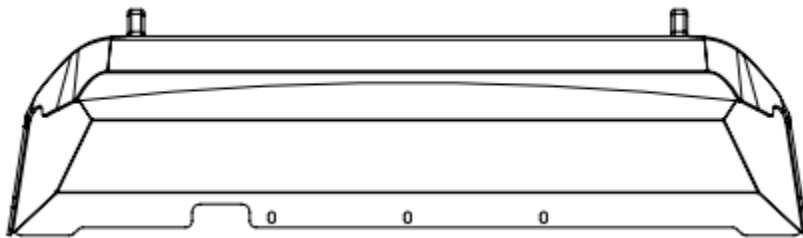

3 - 3/8"-16 X 1" Button Head Bolts
3 - 3/8"-16 Nyloc Nut
3 - 3/8" Washers

7 – CONTINUED

Adjust the bumper to its desired location and TIGHTEN HARDWARE. Check that all hardware is tightened including all brackets and mounting locations. Reconnect the parking sensor wiring harness and other connections to the vehicles electronics and secure all loose wiring. Check that everything is working and adjust if needed before driving on the road

ADDITIONAL LINKS

<https://www.exp-one.com/wp-content/uploads/2016/10/Proper-Care-and-Maintenance.pdf>

<https://www.exp-one.com/wp-content/uploads/2016/10/Paint-touch-up-instructions.pdf>

<https://www.exp-one.com/wp-content/uploads/2018/02/Exp-One-2016-TC-word-doc.pdf>

**TIGHTEN ALL HARDWARE AFTER EVERYTHING IS INSTALLED ON THE VEHICLE
CHECK AND RETIGHTEN ALL HARDWARE AFTER THE FIRST 100 MILES AND AFTER
OFF ROADING. CHECK REGULARLY**