



# DSTC SYSTEMS

## SWING ARMS & LATCHES



## INSTALL GUIDE

EXPDSTC01

### PLEASE READ ENTIRE GUIDE BEFORE INSTALLATION

Recommended that you read this entire install guide before installation. Check that all hardware is present before starting or scheduling an install. This guide is supplemental to mechanical knowledge and ability. Anyone not familiar with automotive installation should seek professional installation.



# INSTALL GUIDE

## IMPORTANT INFO/FAQ

### INSTALL GUIDE

ALL

#### INSTALLATION HELP

Please review terms and conditions for details

Recommended purchaser review Welcome Guide at time of purchase for details

Care and Maintenance available at [www.exp-one.com/resources](http://www.exp-one.com/resources)

We do our best to offer timely assistance with your installation questions however as most of our team members are primarily engaged in the manufacturing process and packaging processes, we do not currently offer a tech for on-demand calls and inquiries. For the more technical installs or installs that are time-sensitive in nature, we would recommend our customers seek out the services of professional shops with experience specific to aftermarket bumpers that can better meet your needs. We are happy to make recommendations to you on shops familiar with our products in your area. We do our best to respond to installation questions within 24-48 hours of contact as much as possible. Long-distance problem assessment can be difficult, so photos and videos are often required for us to best assist you. We highly recommend your initial contact regarding installation questions include both close-up and full photos, detailed descriptions using our part descriptions as much as possible, and video. This enables us to better assist without having the ability to see the install difficulties directly and assist you as quickly as possible.

#### NOTE

Expedition One does not guarantee fitment with other aftermarket products, or reinstallation of take off OEM parts.

Expedition One is NOT RESPONSIBLE for damage to paint or powder coating, items assembled in error during installation or costs associated with install

OEM manufacture model refreshes/updates, factory build location and suppliers may cause variations in fitment or installation and can not be verified, vehicle to vehicle .

\*This product contains chemicals known to the state of California to cause birth defects or other reproductive harm. For more information go to [www.p65warnings.gov](http://www.p65warnings.gov)\*

GSA# GS-30F-013CA

EXPEDITION ONE  
113 N. 700 W. BUILDING 5C BAY 1  
OGDEN, UT 84404  
INFO@EXPEDITIONONE.BIZ  
801-627-2921

\*This product contains chemicals known to the state of California to cause birth defects or other reproductive harm. For more information go to [www.p65warnings.gov](http://www.p65warnings.gov)\*















### INSTALL GUIDE

ALL

#### HARDWARE

Please review for details and installation. Figures or data may vary. Leave all accessible hardware loose for installation and tighten all hardware after everything is installed on the vehicle. Check and retighten all hardware after the first 100 miles and/or after off roading. **Some hardware locations do not require being tightened to spec due to there design, location or material attachment (including rubber, plastic, and aluminum). Over tightening may break or damage parts. Torque spec may vary, amounts listed are generic.**

HARDWARE		TORQUE SPEC – FT.-LBS.	
SIZE	SOCKET WRENCH	GRADE 5 M- 8.8	GRADE 8 M – 10.9
#8	1/4"	X	
#10	5/16"		
1/4"	7/16"	6-8	9-10
5/16"	1/2"	13-14	18-20
3/8"	9/16"	23-26	33-37
7/16"	5/8"	37-41	52-58
1/2"	3/4"	57-64	80-90
9/16"	13/16"	82-91	115-129
5/8"	15/16"	112-118	159-180
3/4"	1-1/8"	200-223	282-315
7/8"	1-5/16"	322-355	454-501
1"	36MM	X	
M6	10MM	9-10	13-15
M8	13MM	22-24	32-35
M10	15MM	44-49	64-72
M12	18MM	76-83	112-123

TYPES OF HARDWARE		
		
HEX CAP BOLT	WASHER	NYLOC NUT
		
BUTTON HEAD BOLT	FENDER WASHER	HEX NUT
		
CARRIAGE BOLT	INTERNAL TOOTH	JAM NUT
		
SOCKET CAP BOLT	CLIP NUT	ACORN NUT
		
FLAT HEAD SCREW	RIVET NUT	COUPLING



GRADE5



CLASS8.8



GRADE8



CLASS10.9

**NOTE - Extra hardware may be left over due to model or option specific items that may not be required for the install.**

### INSTALL GUIDE

EXPDSTC01

#### KICK PLATE

A Kick Plate	2
B Kick Plate Bump Stop	4
C Kick Plate Nyloc Squares	4
D Kick Plate Aluminum Spacers	4
E Welded Rod Plate	2
F Latch Assembly	2

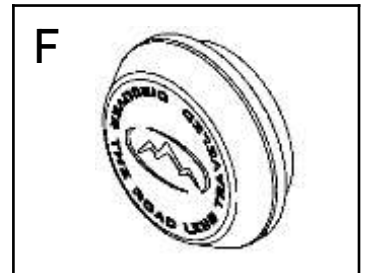
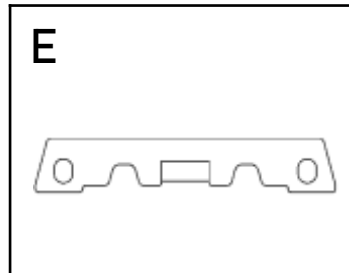
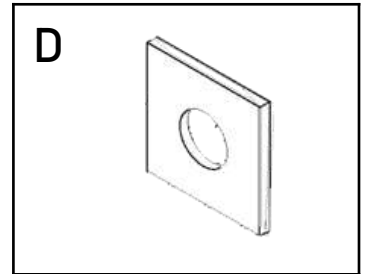
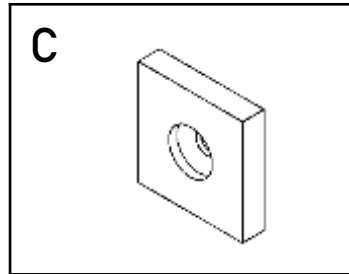
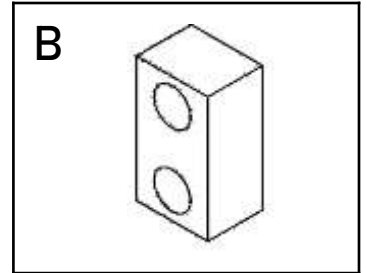
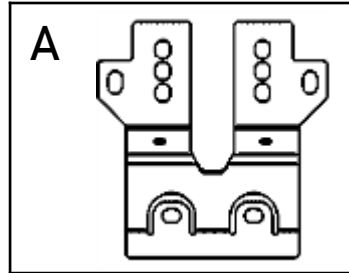

#### HUB KIT

F DSTC Hub Cover	2
G Hub Cover O-Ring	2
H Bearing	4
I Grease Seal	2
J Spindle Hardware	
1"-1 4 Nyloc Nut	2
1" X 2.000 USS Washer	2
O-Ring	2
Anti Seize	1

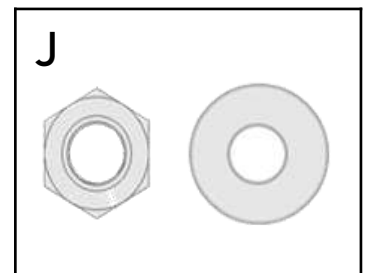
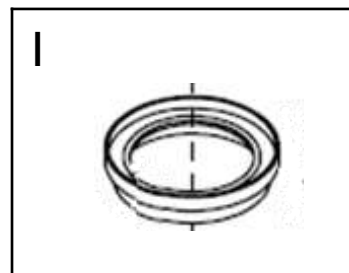
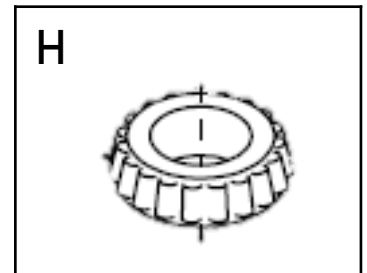
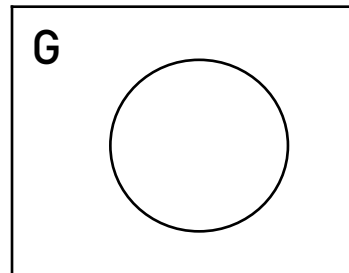

# DROP PINS AND PIN PLATES

## FULL SIZE TRUCK

K Full Size Truck Drop Pin 2

L Full Size Truck Pin Plate 2

Note – XD pins will have an hourglass logo

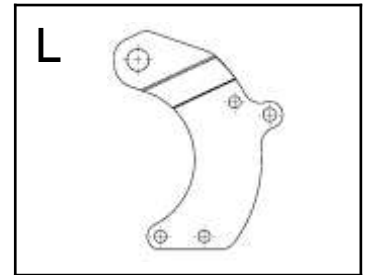
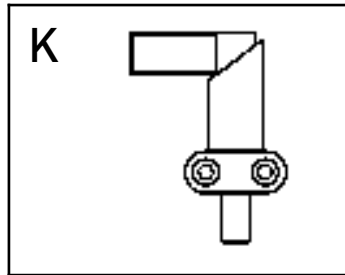

## MID SIZE TRUCK

M Mid Size Truck Drop Pin 2

N Mid Size Truck Pin Plate 2

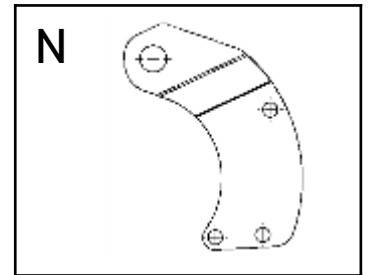
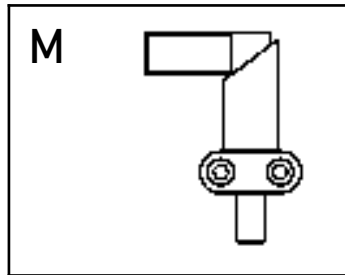

## SUV

O SUV Drop Pin 2

P SUV Pin Plate 2

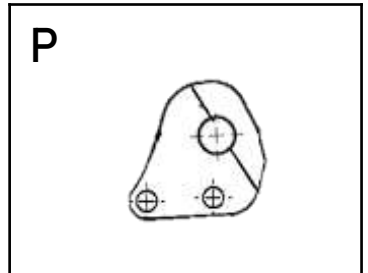
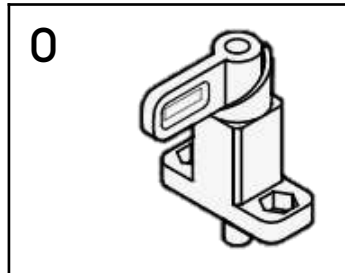

## Q Kick Plate Assembly Hardware

10 – 32 x 3/4" HEX DRIVE BUTTON HEAD 4

10 – 32 x 1 1/4" HEX DRIVE BUTTON HEAD 4

10 – 32 NLYOC NUT 4

1/4" – 20 x 3/4" HEX DRIVE BUTTON HEAD 14

1/4" – 20 x 3/4" COUNTER SINK SCREW 4

1/4" – 20 NYLOC NUT 8

1/4" – 20 EXTENDED CLIP NUT 8

5/16" – 18 x 3/4" HEX CAP SCR 8

5/16" – 18 x 1" HEX CAP BOLT 4

5/16" – 18 x 1" CARRIAGE BOLT 6

5/16" x 0.688" SAE WASHER 8

5/16" x 0.875" USS WASHER 6

5/16" – 18 NUT 2

5/16" – 18 NYLOC NUT 18

5/16" – 18 ACORN NUT 2

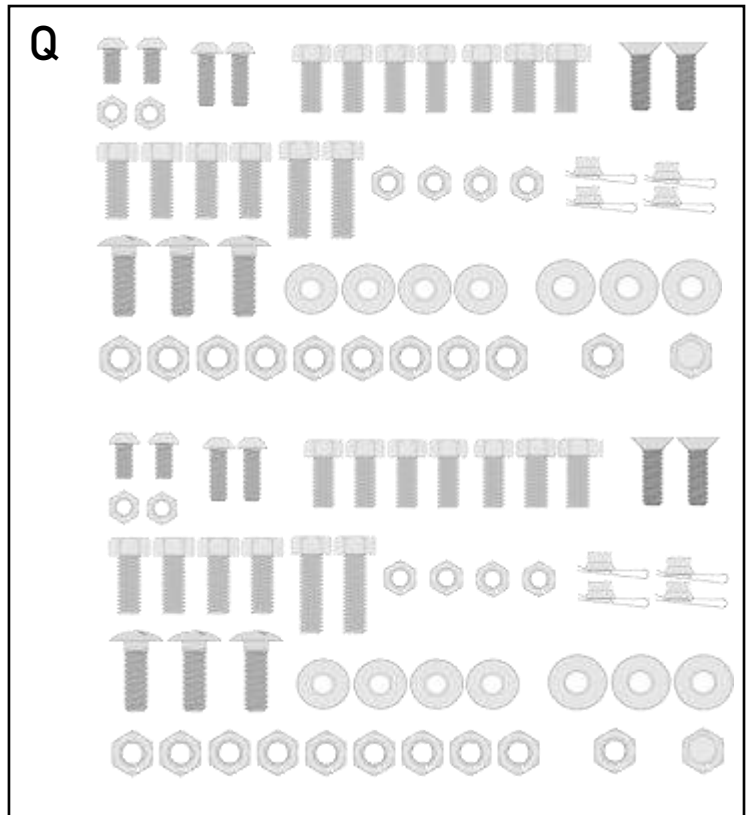

# LATCHES AND HANDLE MOUNTS

## LATCH

**R Latch Assembly** 2

**S Latch Hardware** 2

See Kickplate Hardware Kit

**Q Kick Plate Assembly Hardware**

5/16" - 18 x 1" CARRIAGE BOLT 6

5/16" x 0.875" USS WASHER 6

5/16" - 18 NUT 2

5/16" - 18 NYLOC NUT 4

5/16" - 18 ACORN NUT 2

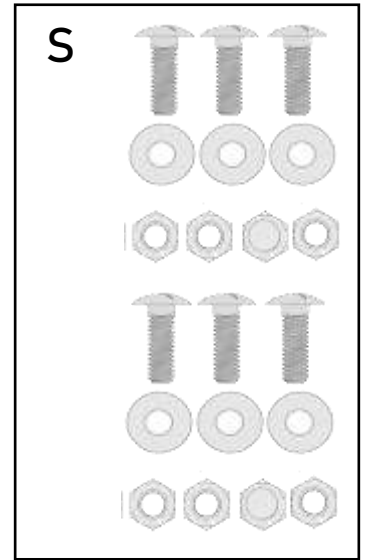
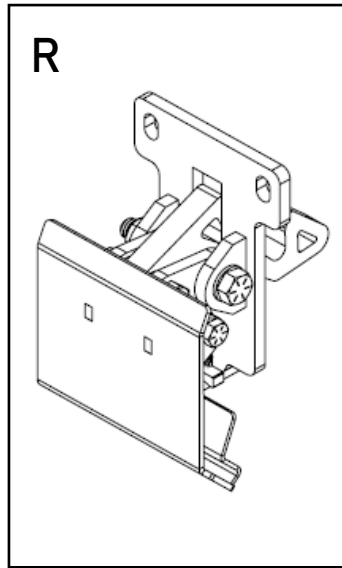

## TRUCK

**T Truck Handle Mount** 2

## SUV

**U SUV Handle Mount** 2

**V Handle Mount Hardware**

1/2" - 13 x 1 1/2" HEX CAP BOLT 8

1/2" - 13 x 1 1/2" BUTTON HEAD BOLT 4

1/2" USS WASHER 12

1/2" - 13 NYLOC NUT 8

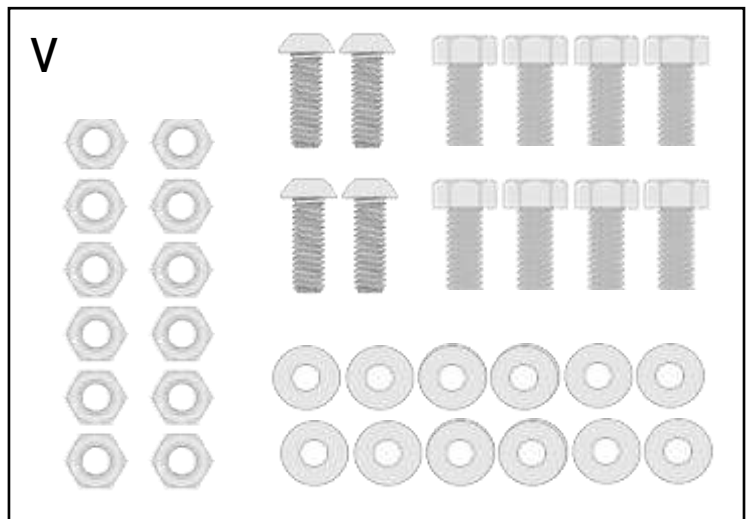
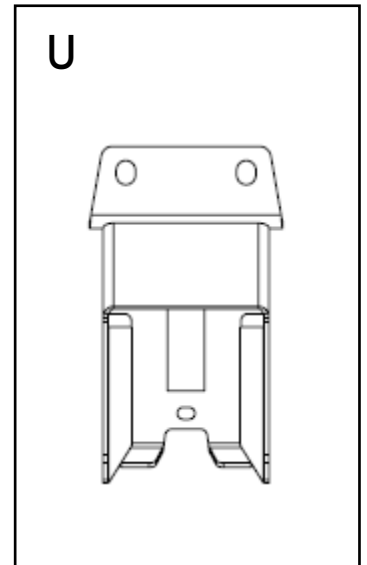
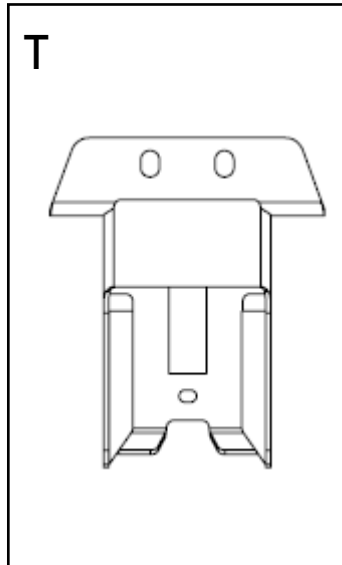

## NOTE

Sprinter and Truck XD Arms DO NOT use any Bolt on handle mounts. They are welded on.

Extra hardware may be left over.

# KICKPLATE ASSEMBLY

Assemble both kickplates as shown below.

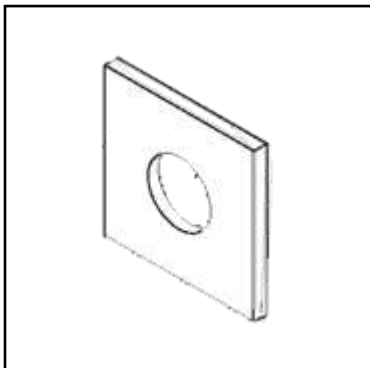
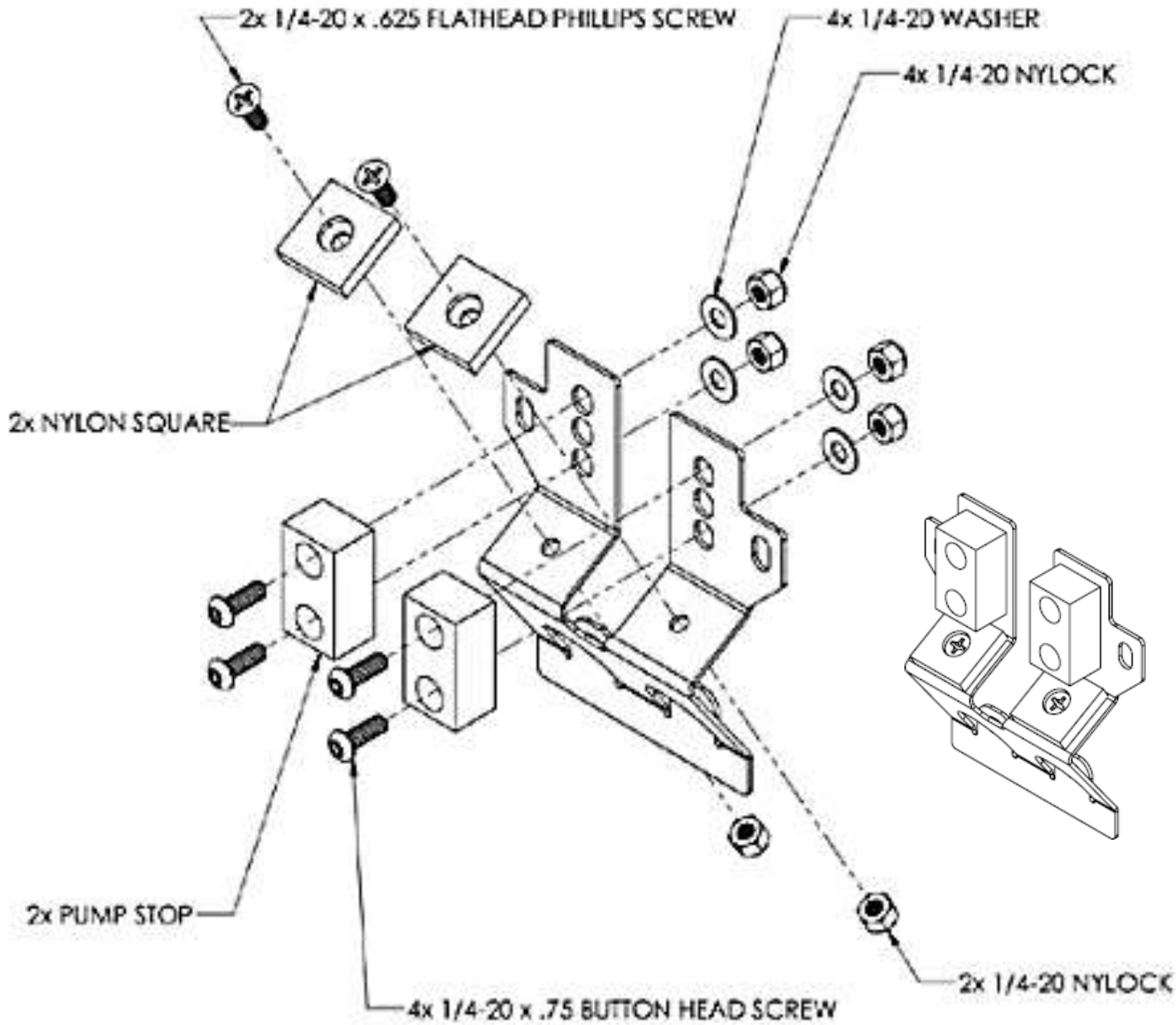

## NOTE

Aluminum spacers provided for adjustment of nylon squares if required. See fitment of closed arm and use as needed.



# KICK PLATE INSTALLATION

Assemble both kickplates as shown below.

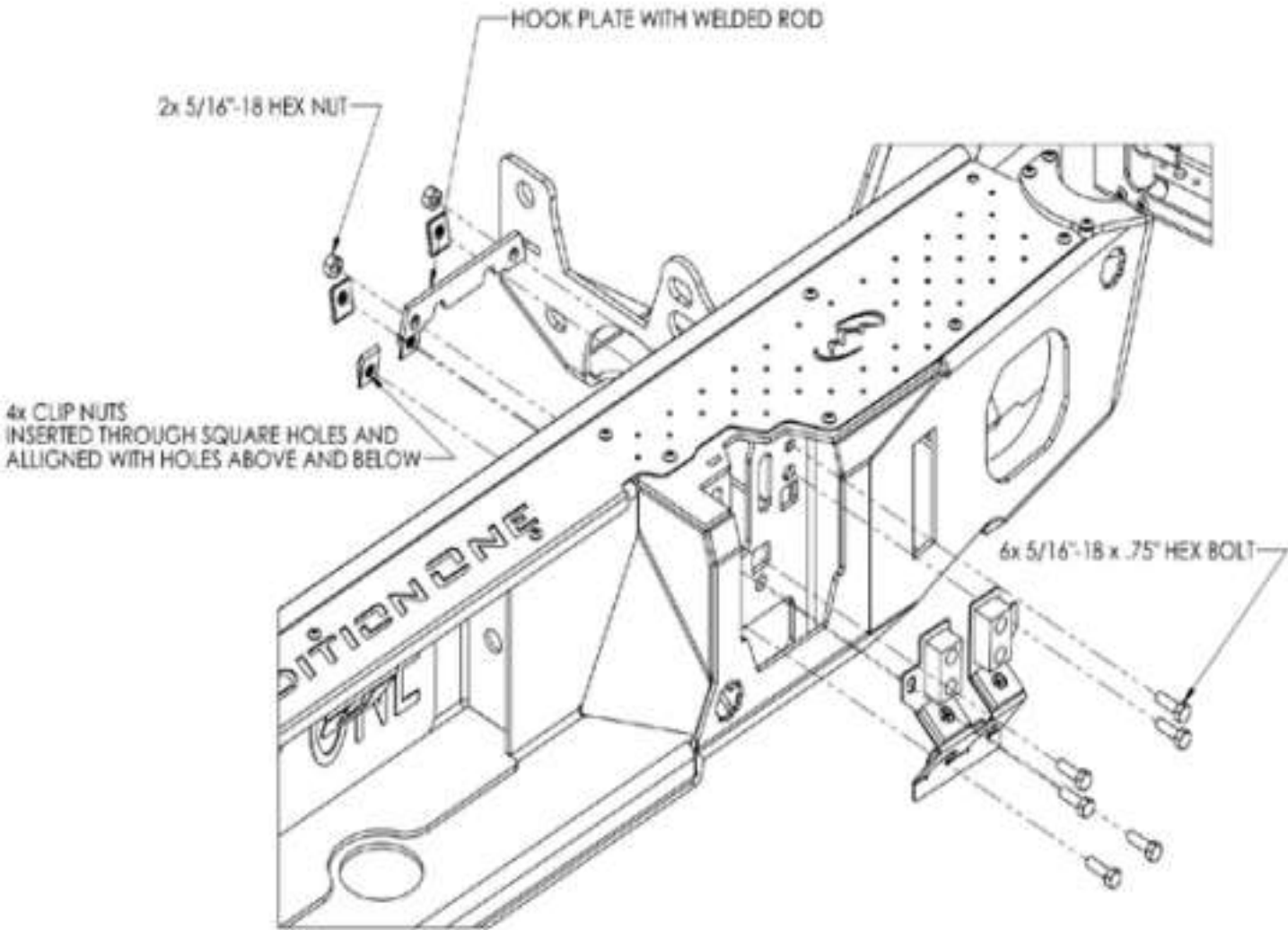

Welded Rod Plate should face inside the bumper and mounted in the upper most position.



Adjust the Kickplate as needed for best arm contact and latch travel.



# DROP PIN INSTALLATION - TRUCK

Install the drop pins as shown for each swing arm.

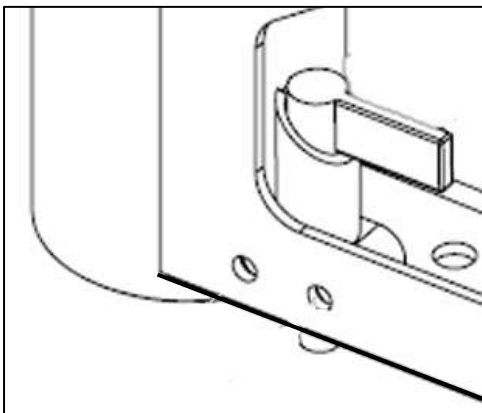
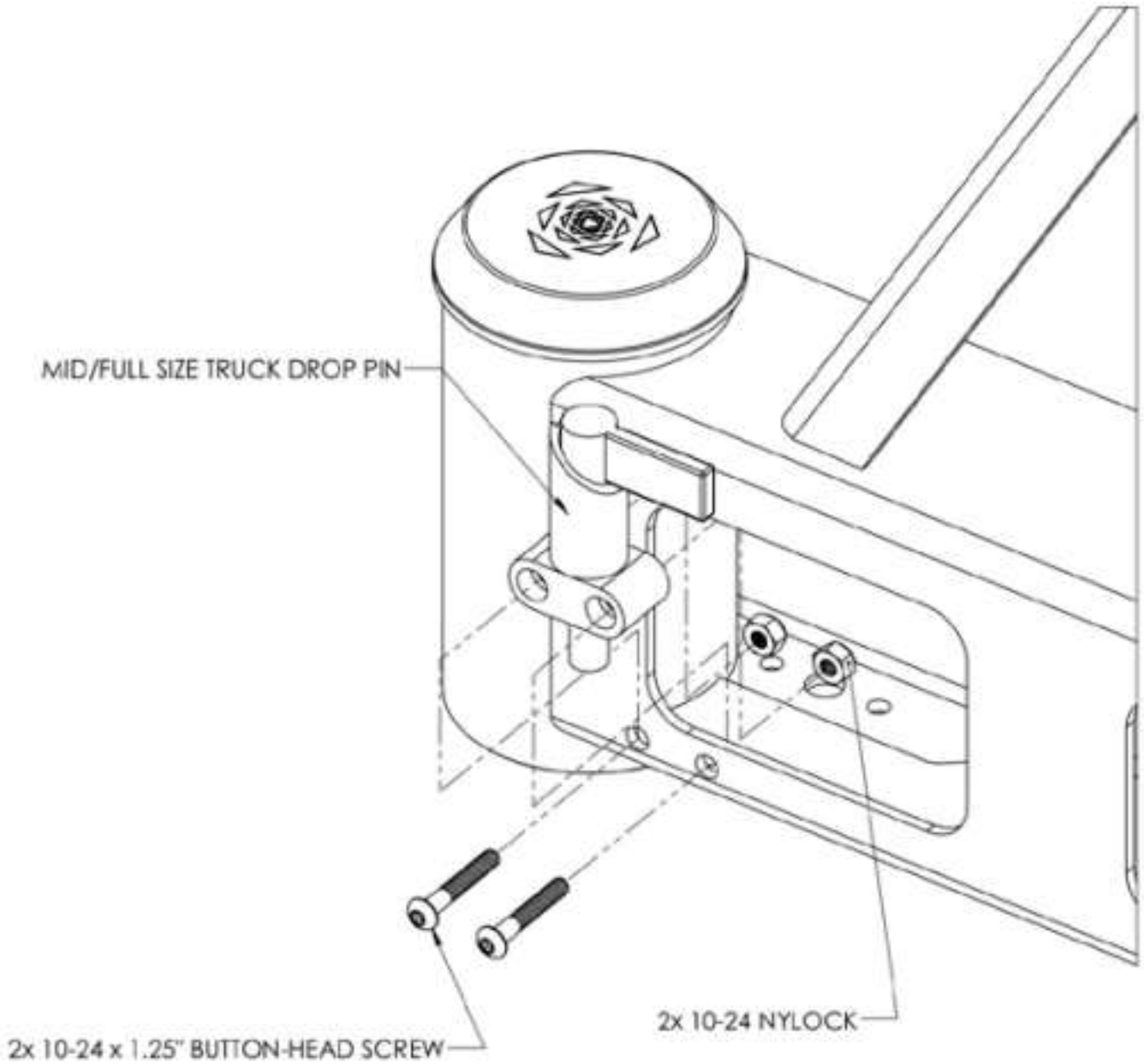

## NOTE

Drop pins will mount inside of the arm

# DROP PIN INSTALLATION - SUV

Install the drop pins as shown for each swing arm.

SUV DROP PIN

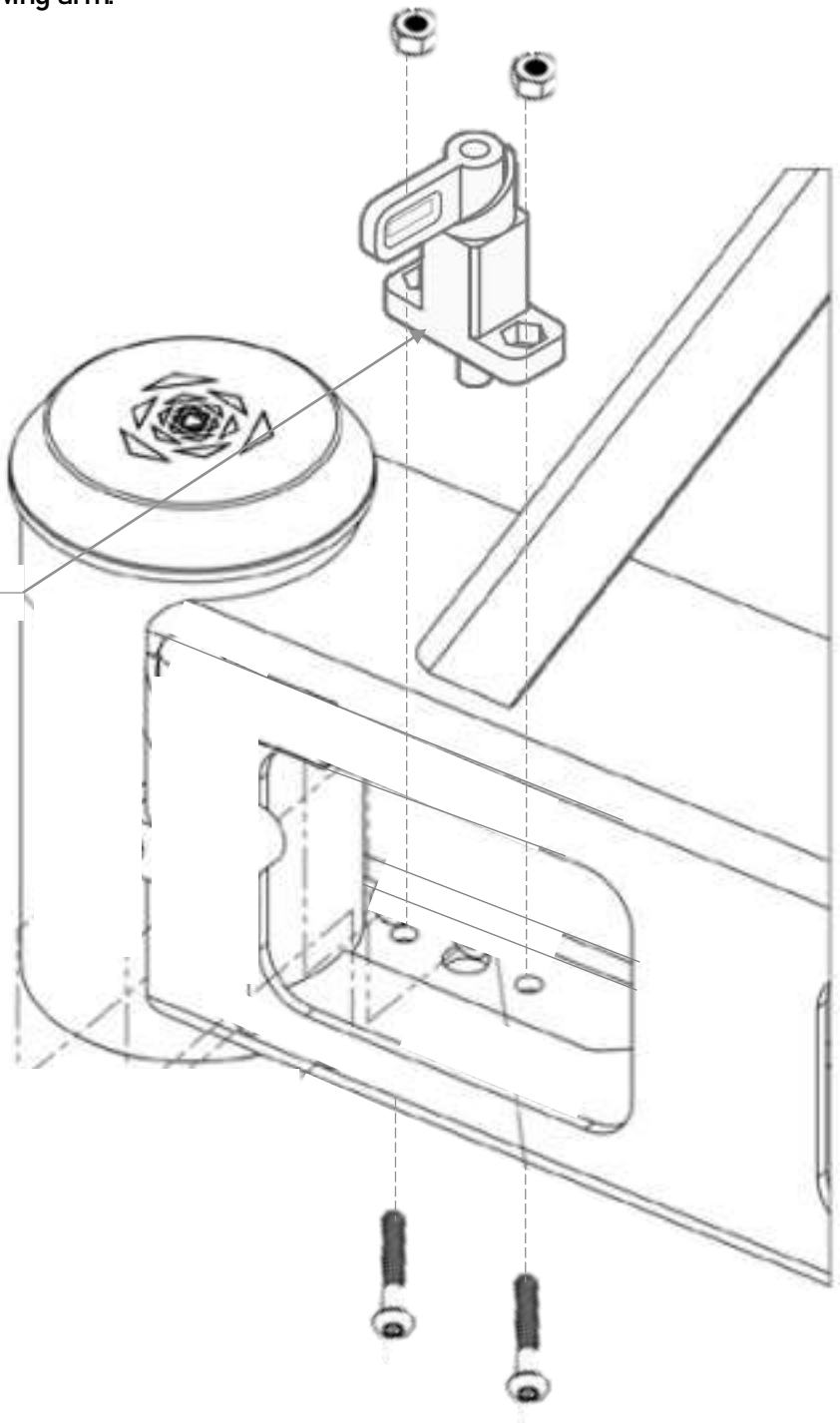
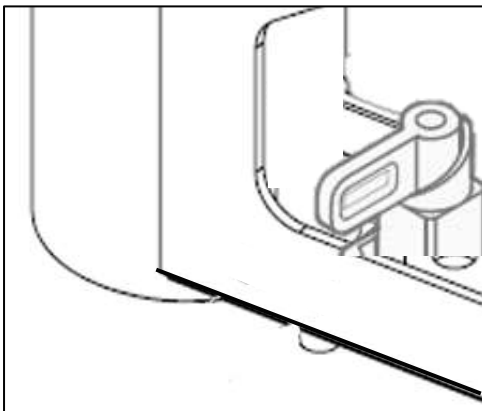

## NOTE

Drop pins will mount inside of the arm

# ARM MOUNTING

Attach the arm to the bumper spindle as shown.

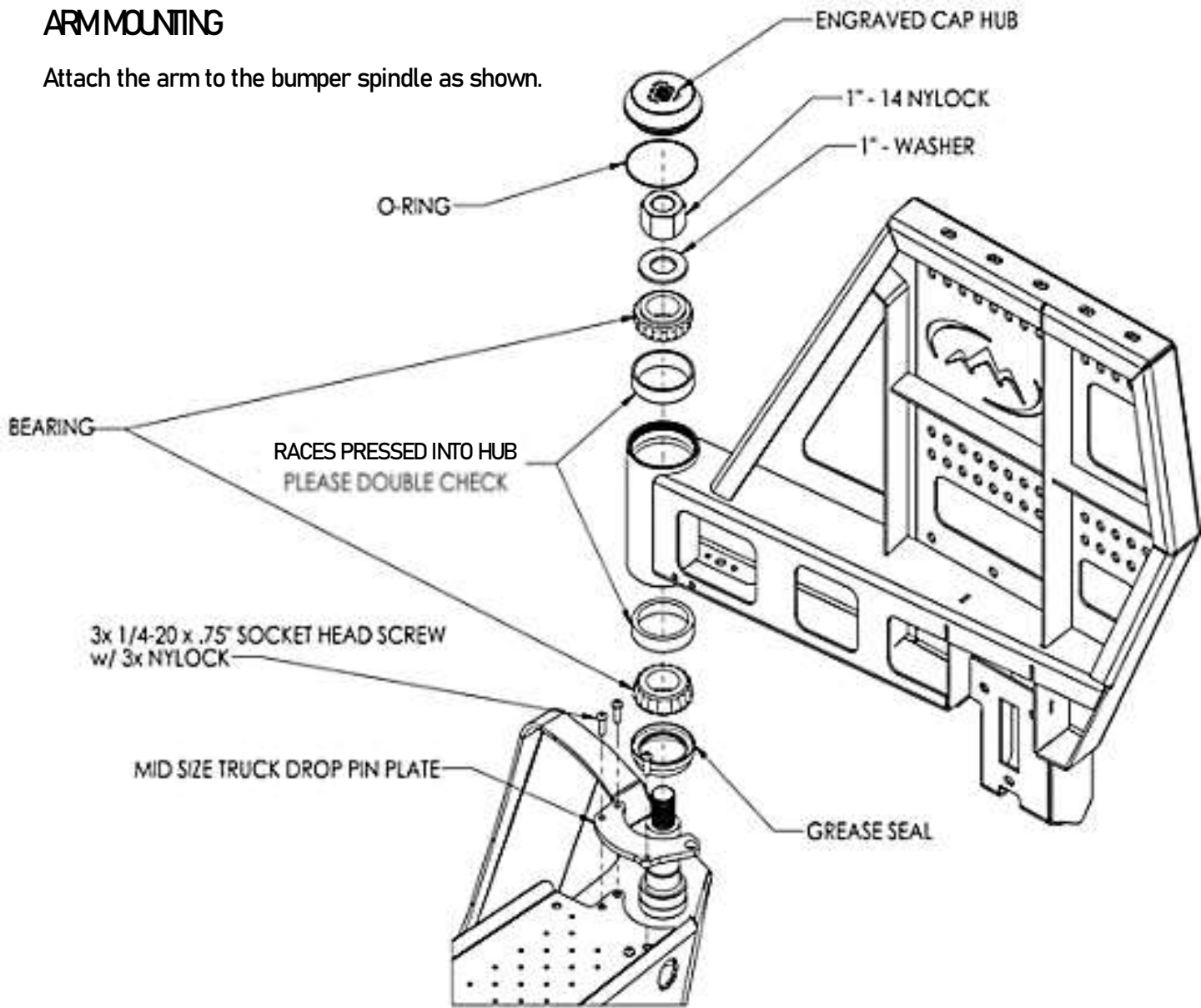

## 1 - BOTTOM BEARING AND GREASE SEAL

Grease Bearings using marine-based lithium grease. Install the first bearing into the bottom of the swing arm. Then Place a grease seal inside the bottom of the arm.



## 2 – DUAL SWING ARM INSTALLATION

Unclip and remove the lower bumper from the vehicle. Check for any remaining hardware or connections before removing.



## 3 – SPINDLE HARDWARE

Place the washer into the swing arm, then insert the nut over the bolt. Tighten the nut using a 36mm socket. Don't over tighten to prevent binding.

## 4 – HUB COVER

Check that the hub cap has a O-ring and spread anti-seize around the cap before tightening on the arm. Repeat each step for the other arm. Install the drop pin plate as shown in the diagram page



### NOTE

Use of the provided Anti Seize will allow for hub covers ease of removal for future maintenance.

## REPLACEMENT PARTS

Replacement parts available at local auto part stores or directly from the Expedition One Store (see Replacement Parts tab)

### PART NUMBERS

Bearings – LM48548 or A5

Grease Seal – (MS or PN) 5121

# HANDLE MOUNTING

Mounted the latch handle into position as shown below.

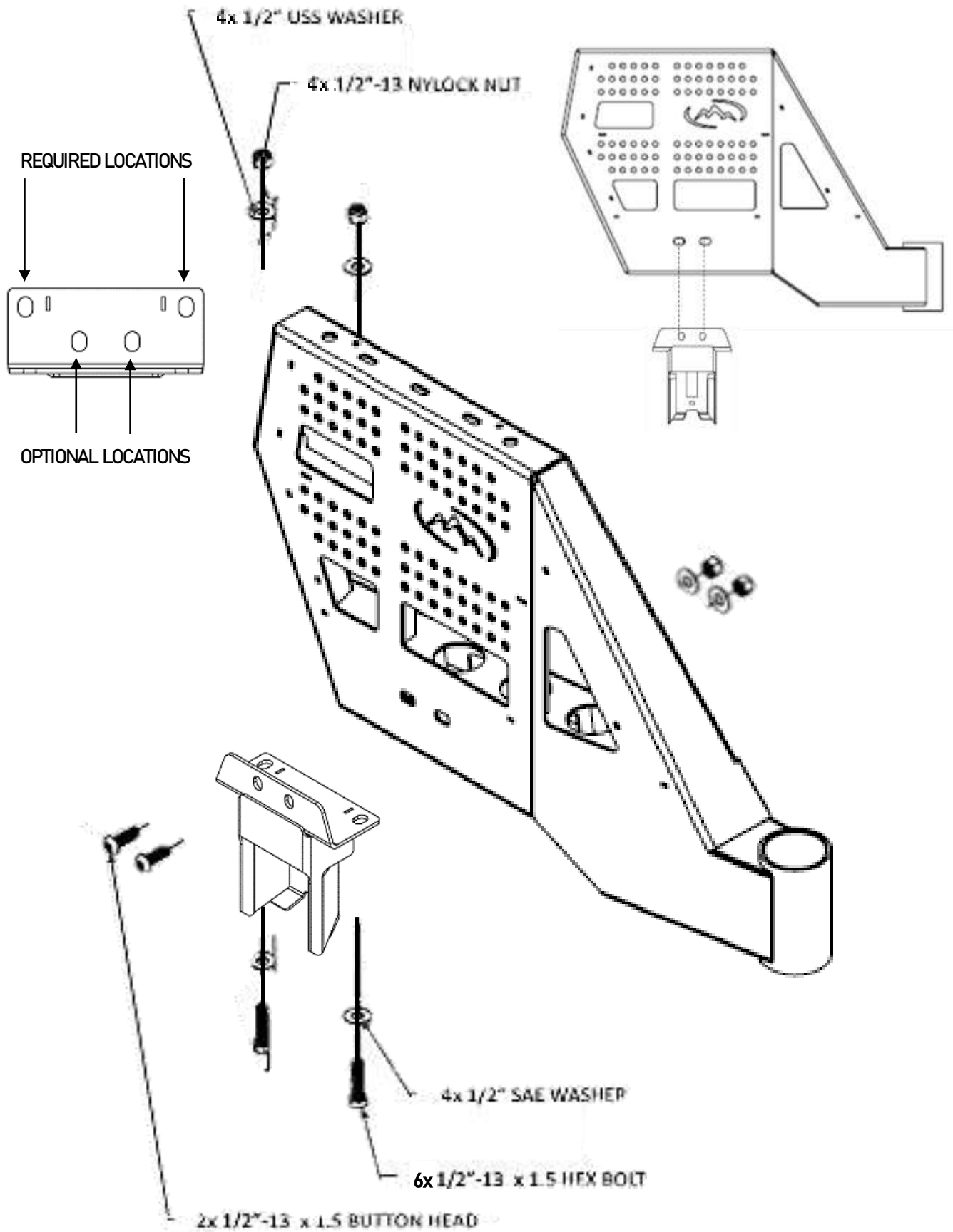

# HANDLE MOUNTING

Mounted the latch handle into position as shown below.

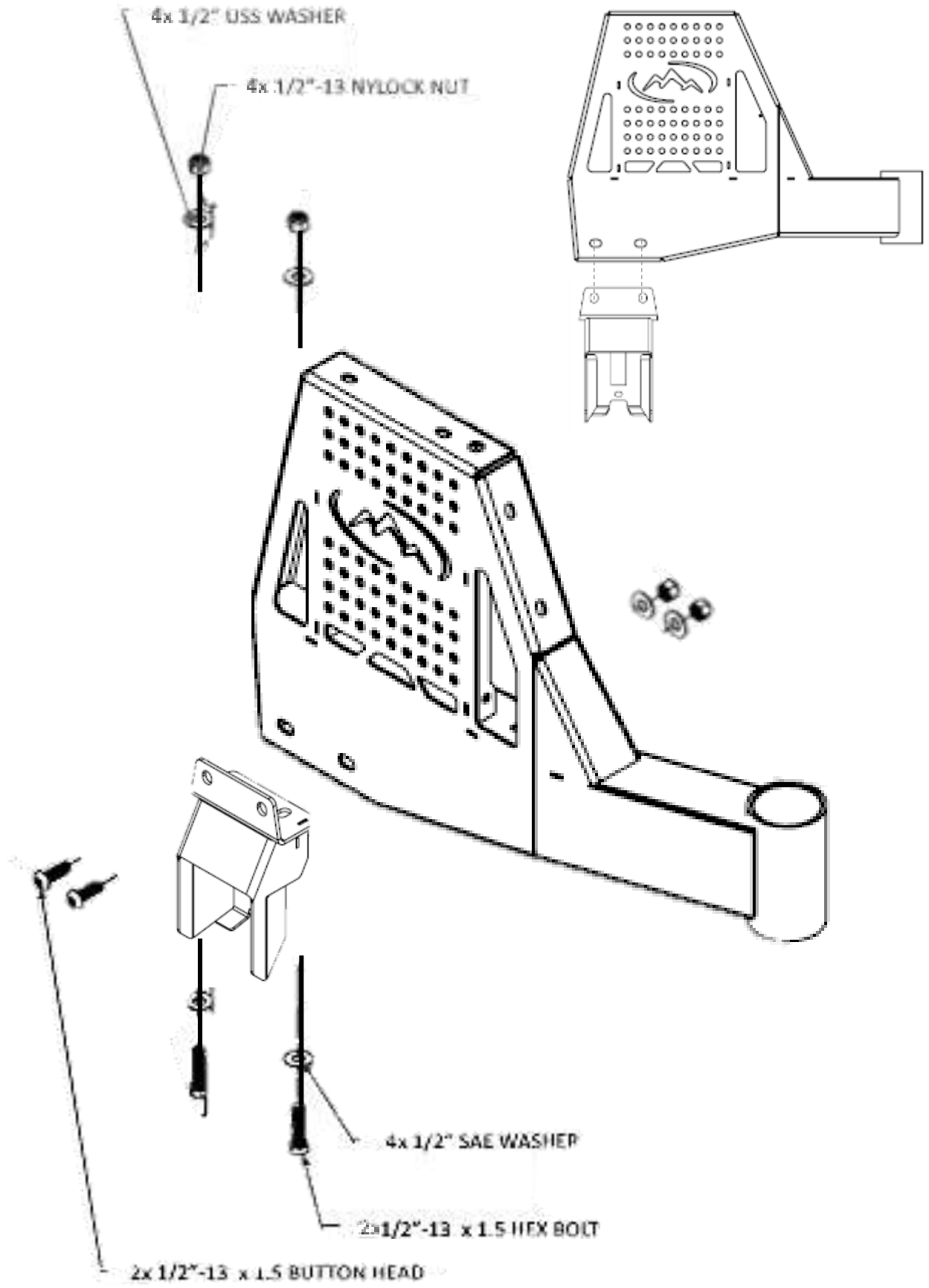

## LATCH MOUNTING

Install the latch assembly as shown. The latch may require adjustment for fitment and alignment with the arm and bumper kick plate.

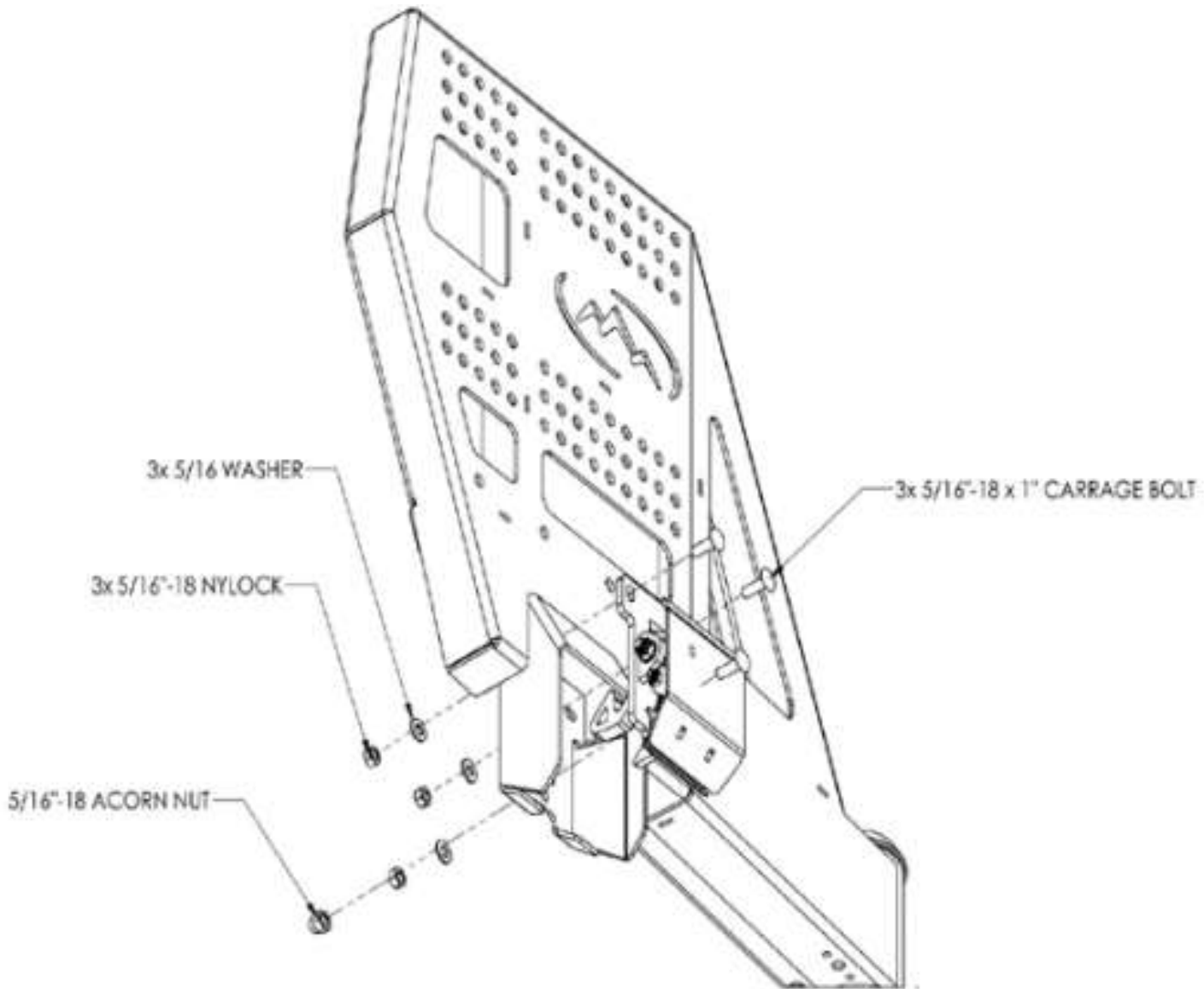



# CARE & MAINTENANCE

Re-tighten your coupling unit after a period of time or after a good off-road trip. Looseness in your hub assembly or seizing of your carrier may be a sign you need to replace your bearings or that the 1" Nyloc nut in under the cap in your hub assembly has come loose and needs to be tightened.

Always be sure to use the anti-seize when installing and re-installing your hub cover, otherwise removal will be very difficult! Remove your hub cover and check inside your hub assembly regularly. If you live in a dry climate and off-road a "standard" amount, we would recommend you check your hub assembly at least once per year. If you live in a wet climate, humid climate, or a climate with extremes, we would recommend you check your hub assembly quarterly or with season changes. Climates with heavy salt content are some the harshest conditions on your components and may need to be checked more frequently.

When installing and/or re-installing bearings be sure to use a white lithium marine-style grease for best results. Once you have removed the cap, check the grease. Bad grease will be black or have lost most of its original color, will show signs of moisture, and/or will have become "chunky". If this is the case, remove your bearings and re-grease them. Check your bearings. The bearing cage can become corroded over time and break. Looseness or seizing in your hub and carrier assembly may be a sign that you need to replace your bearings. Races generally do not need to be replaced unless you can see they have broken or are heavily corroded. Races can be knocked out and replaced if/when needed.

Replacement parts. You can purchase a rebuild kit directly from us at Expedition One, however you can also find most of your hub assembly components at your local automotive/hardware store. Replacement part #'s can be found below for your convenience:

## **Dual Swing Arm Carriers**

**Grease Seals: PN 5121**

**Bearings: LM48548 or A5**

Stiffness, binding, or rattling in your tire carrier arm may be an indicator for maintenance needed on the bearings in your hub assembly. This could be caused by a number of factors including environment, impact, lack of/type of grease, corrosion, and/or over-tightening.

Our carriers are designed for easy maintenance with easy removal of the hub cap to access the hub assembly. Zinc fittings are generally not necessary, due to ease of access. Wear components and replacement parts can be easily sourced from your local auto parts store and often have a variety of brands/pricing. The bearings used are a high-speed/high heat wheel bearings, but for our applications are being used under moderate loads and low speed ( 0 rpms), so they will typically last a long time.

Instructions for bearing checks and maintenance:

- Loosen your hub cover cap. If anti-seize was used this should easily be done by hand or with a simple grip tool.
- Observe the top bearing. If there is a lot of moisture, discoloration, or corrosion you could have a grease problem. We recommend using a water-resistant, marine grade grease for this reason.
- If you do not see a lot of moisture or discoloration and do not want to un-bolt the arm you can first try to pack the hub assembly with a lot of marine-grade grease and cycle it through by moving the arm back and forth. This may fix your problem. If movement is not improving with additional grease and cycling or you believe you have broken bearings continue by unbolting and removing the arm.
- Take out the top bearing and examine it. If it rolls and does not show signs of damage or coming apart then it is probably ok. Check the cage holding the bearings is in-tact. If you see any damage or broken parts you will need to replace the bearing.
- The bottom bearing is held in by the grease seal. You want to gently remove the grease seal by using a hammer and a tool such as a center punch, aul, or screwdriver to gently tap out the grease seal so you can access the bottom bearing.
- Observe and examine the bottom bearing for signs of damage. Again, If the bearing does not roll or if parts are popping out or there is damage to the cage you will want to replace the bearing.
- If the bearings are rolling and are just dirty or gummy, you can use WD40, brake cleaner, or penetration spray to clean them out.

Be sure to re-pack with a lot of marine-grade grease when replacing cleaned and/or used bearings and use anti-seize when re-installing your hub cover cap. Caps should be snug but be careful not to over-tighten, as this can put too much pressure on the bearing cage and cause bearings to fail. We do not provide torque specs, as the exact right tightening for your application can be hard to gauge with the Nyloc nut. We recommend you check to feel the Nyloc has been tightened and that the cap is snug and not to tighten beyond that point.