



INSTALLATION MANUAL

VICOWL

PRODUCT NUMBER: VC4400

APPLICATION: 2019 DODGE RAM HD



IMPORTANT SAFETY GUIDE | Your safety and the safety of others is very important.

In order to help you make informed decisions about safety, we have provided the following warnings, safety precautions, installation instructions, and other important information to alert you to potential hazards that could hurt you or others.

Please do a job safety analysis before each task to identify potential hazards for your situation and remove/protect against them. Use own good judgment and take your time.

Check packaged materials immediately upon arrival to ensure that all listed parts are included and undamaged.

Read and understand all warnings, safety precautions, and instructions before installing this product.

SENSORS FIELD OF VIEW MAY BE ALTERED WITH USE OF THE REPLACEMENT BUMPER.

WARNINGS

- Failure to observe the following warnings and instructions provided in this manual could lead to severe injury and/or death.
- For professional installation only. Careless installation and/or operation can result in serious injury, death, and/or equipment damage. All liability for installation and use rests with the user or consumer.
- Fab Fours, Inc. only approves installing this product according to these written instructions with the hardware provided. Failure to install according to these instructions will invalidate the warranty. This includes, but is not limited to, using alternative installation methods, hardware, or materials.
- This product is for off road use only.

SAFETY PRECAUTIONS

- Always remove jewelry and wear eye protection.
- Always use extreme caution when jacking up a vehicle for work. Set emergency brake and use tire blocks. Locate and use the vehicle manufacturers designated lifting points. Use jack stands.
- Always use appropriate and adequate care in lifting components into place.
- Always ensure components will remain secure during installation and operation.
- Always wear safety glasses when installing this kit. A drilling operation will cause flying metal chips. Flying chips can cause serious eye injury.
- Always use extreme caution when drilling a vehicle. Always disconnect power before welding. Thoroughly inspect the area to be drilled (on both sides of material when possible) prior to drilling, and relocate any objects that may be damaged.
- Always use extreme caution when welding a vehicle. Thoroughly inspect the area to be welded (on both sides of material when possible) prior to welding, and relocate any objects that may be a fire hazard. When welding in a cab, make sure the interior surfaces are covered (e.g., welding blanket) and a fire extinguisher is at hand.
- Always use extreme caution when cutting and trimming during fitting.
- Always tighten all nuts and bolts securely per installation instructions.
- Always route electrical cables carefully. Avoid moving parts, components that become hot, and rough or sharp edges.
- Always insulate and protect all exposed wiring and electrical terminals.
- Perform regular inspections and maintenance on mounts and hardware.

TABLE OF CONTENTS

2	SAFETY / DISCLAIMER
3	TABLE OF CONTENTS
4	A MESSAGE FROM THE OWNER
5	GETTING STARTED
6	PROVIDED MATERIAL
8	DISASSEMBLY
11	INSTALLATION
24	CONTACT

A MESSAGE FROM THE OWNER



Fab Fours' was born out of a passion for customizing vehicles and a love of the outdoors. Our engineering team uses the latest 3D design software to turn new product ideas into reality. In our factory, designs come to life with the combination of cutting edge technology for metal cutting and forming and an American workforce that puts its' heart and pride into every product.

From design and manufacturing, to quality and delivery, Fab Fours' mission is to be the market leader for steel truck and jeep accessories. We make sure a quality product is delivered on time, more than expected, better than expected to our customers.

Enjoy your new Fab Fours product. Welcome to the family!

Ereg Higgs

FOUNDER, FAB FOURS

GETTING STARTED

Before you begin the installation process of your new Fab Fours product, we suggest laying out all materials and parts on a pad or protective surface.

Failure to fully account for all components before beginning installation may leave vehicle immobile until part is acquired. Refer to the next pages as an inventory check.

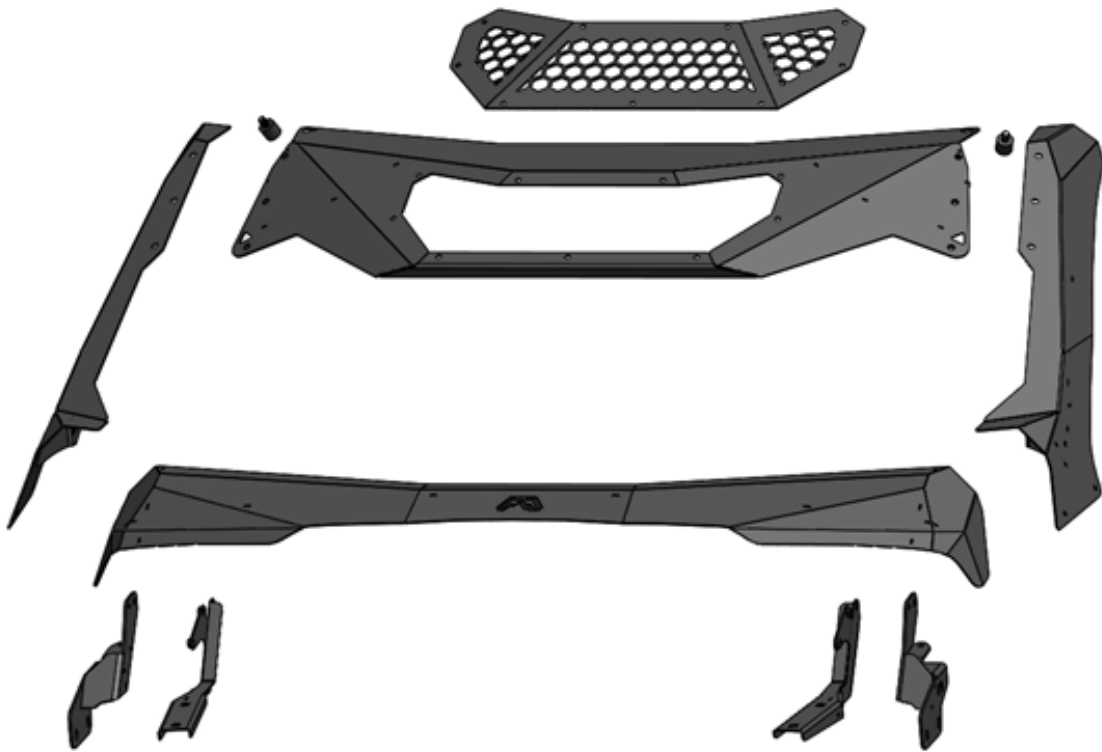

PROVIDED MATERIALS

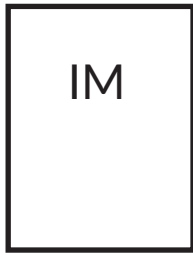

VC4400-IM



50113-HW



61720
QTY: 2



22063



22064

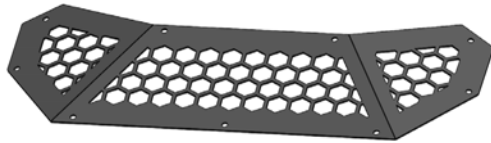

21313



22062



61724



22059



22060



22061



22065



61723



22066

HARDWARE KIT | 50172

FAB FOURS IDENTIFICATION	COMPONENT DESCRIPTION	QTY
50113- HW	½" Yellow Zinc Flat Washer	2
50113- HW	⅜"-16 x 1.25" Yellow zinc Hex Cap Bolt Grade 8	8
50113- HW	⅜" Yellow Zinc Flat Washer Grade 8	10
50113- HW	⅜" Yellow Zinc Lock Washer Grade 8	6
50113- HW	⅜"-16 Yellow Zinc Nyloc Nut Grade 8	2
50113- HW	5/16"-18 x .75" Yellow Zinc Hex Cap Bolt Grade 8	2
50113- HW	5/16" Yellow Zinc Flat Washer Grade 8	2
50113- HW	5/16" Yellow Zinc Lock Washer Grade 8	2
50113- HW	⅜"-16 x .75" Stainless Steel Button Head Bolt	10
50113- HW	⅜" Stainless Steel Rubber Bonded Flat Washer	10
50113- HW	5/16" -18 x .75" Stainless Steel Button Head Bolt	9
50113- HW	5/16" Stainless Steel Rubber Bonded Flat Washer	9
50113- HW	5/16" Stainless Steel Flat Washer	9
50113- HW	5/16"-18 Stainless steel Nyloc Nut	11
50113- HW	10mm Stainless Steel Ball Stud 5/16"-18 Threads	2
50113- HW	Blue Loctite Treadlocker .02oz Capsule	1
50113- HW	Oil-embedded Thrust Bearing	2
50113- HW	Oil-Embedded Flanged Sleeve Bearing	2
50113- HW	⅜"-16 Yellow Zinc Knurled Riv-Nut	4
50113- HW	17/32" Drill Bit, ½" Shank	1
50113- HW	⅜"-16 Riv-Nut Insert Tool	1

TOOLS REQUIRED

- 3/16" Allen Wrench
- 7/32" Allen Wrench
- 10mm open end wrench
- Pair of 9/16" socket wrenches
- Pair of 1/2" wrenches
- 8mm socket wrench
- 15mm socket wrench
- Snips
- Locating center punch
- 1/8" drill bit
- 1/4" drill bit
- 3/8" Drive impact wrench
- Blue painters tape
- Pen or Pencil
- Utility Knife
- Plastic panel pry bar
- Hammer
- Drill
- Medium size 3/8" Drive Extension
- 3/8" Drive swivel
- Plastic cutting tool

ASSISTANCE

We recommend two people perform the installation as items are heavy and may need to be held in place while installing.

ORGANIZATION

Disassemble the vehicle where you can catalog and store everything. We suggest labeling and bagging all the OEM bolts when removing from the vehicle. Failure to keep track of parts could lead to an inability to properly reinstall components.

DISASSEMBLY

1. Using an 8mm Socket wrench and plastic panel pry tool, remove the two (2) screws and one (1) push pin from the rear splash shield trim. (Figure 1)

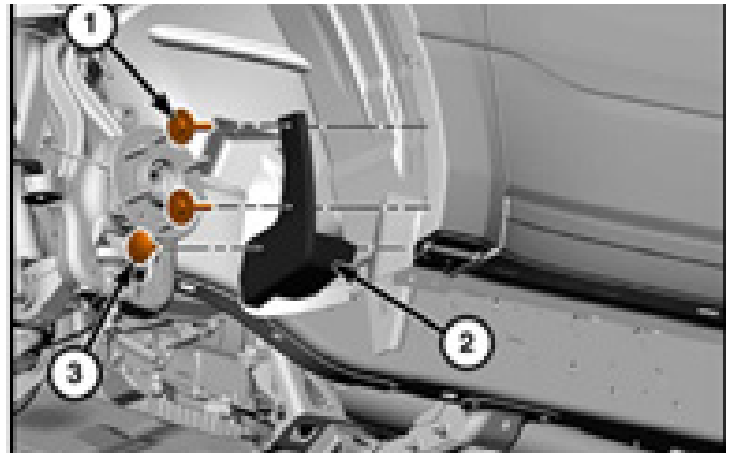

Figure 1

2. Using an 10mm socket wrench and plastic panel pry tool, remove the twelve (12) screws and two (2) push pins from the inner fender and set aside for trimming. (Figure 2 and 3)

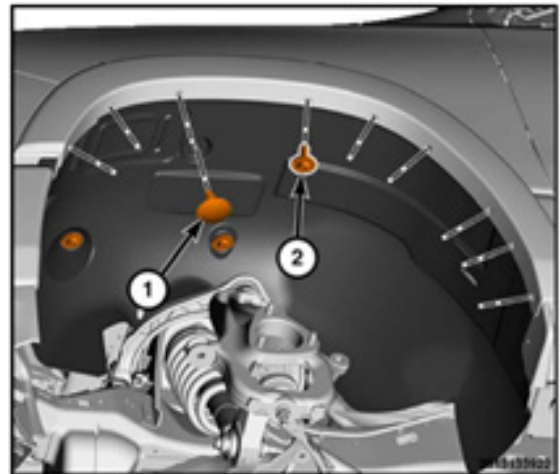

Figure 2

3. Apply Blue tape on each side of the hood and fender. Using a pen or pencil, mark the tape with a straight-line perpendicular with the hood and fender body seam. Use a utility knife to cut the tape along the same seam.

4. Lift the hood

5. Unclip the windshield squirter line from the driver side hood hinge and disconnect at the quick disconnect point.

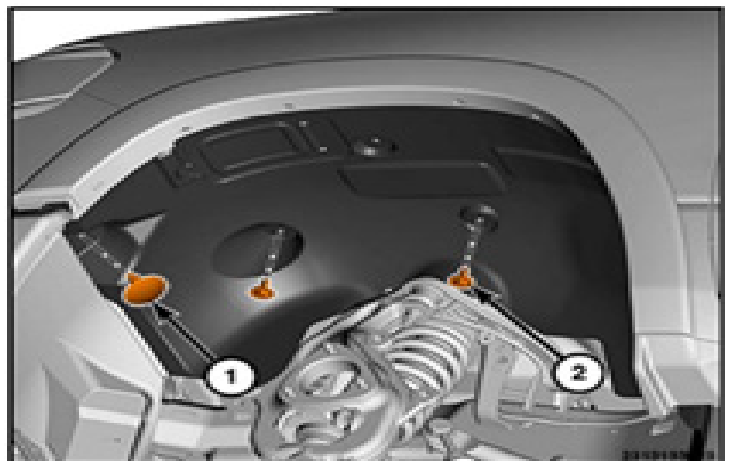

Figure 3

6. Using a socket wrench and with assistance, remove the four bolts securing the hood to the hood hinges. (Figure 4)

NOTE: Be mindful that the passenger side and driver side wiper arms are different lengths and should be marked or tagged appropriately for reinstallation.

7. Using small flat head screwdriver, pull the gas shock ball end retaining clip until the ball socket separates from the gas shock. Perform this step on both gas shocks. (Figure 5)

8. Using a 10mm socket wrench, remove the one (1) Oem bolt securing the fender to the hood hinge bracket. Perform this step on both driver and passenger side hood hinge.

9. Using a 13mm socket wrench, remove the two (2) Oem bolts securing the hood hinge to the body side. Perform this step on both driver and passenger side hood hinge. (Figure 6)



Figure 4

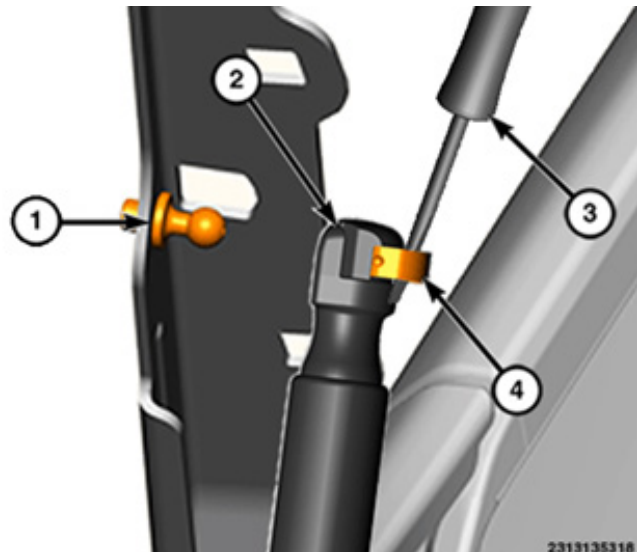

Figure 5

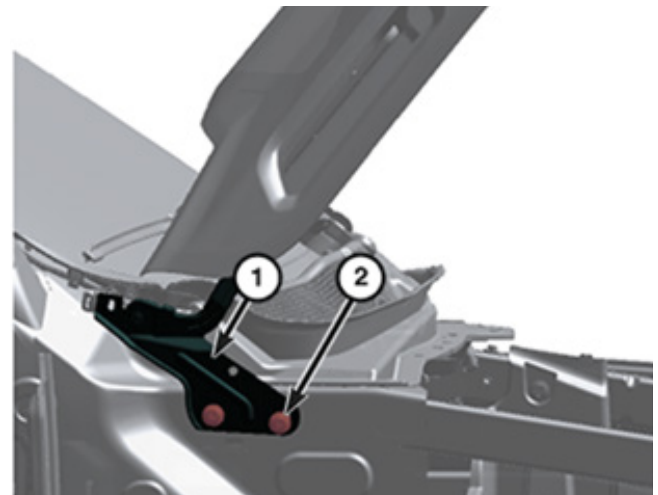

Figure 6

10. Using plastic panel pry tool and a 15mm socket wrench, remove the plastic nut cap and remove the two (2) Oem wiper arm nuts. (Figure 7)

11. Remove both wiper arms.

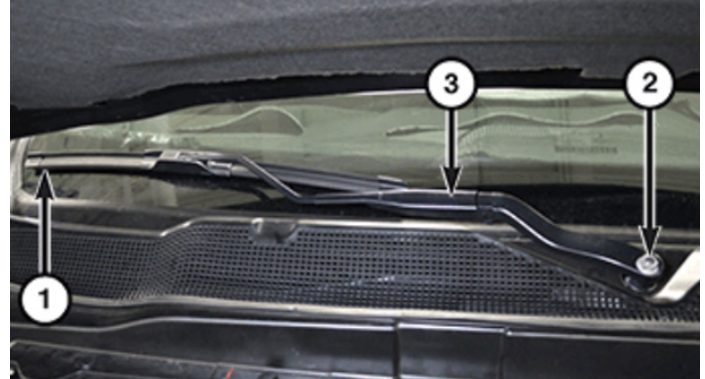

Figure 7

12. Using a plastic panel pry tool, unclip two (2) spring clips and remove the wiper cowl end cap from both sides. (Figure 8)

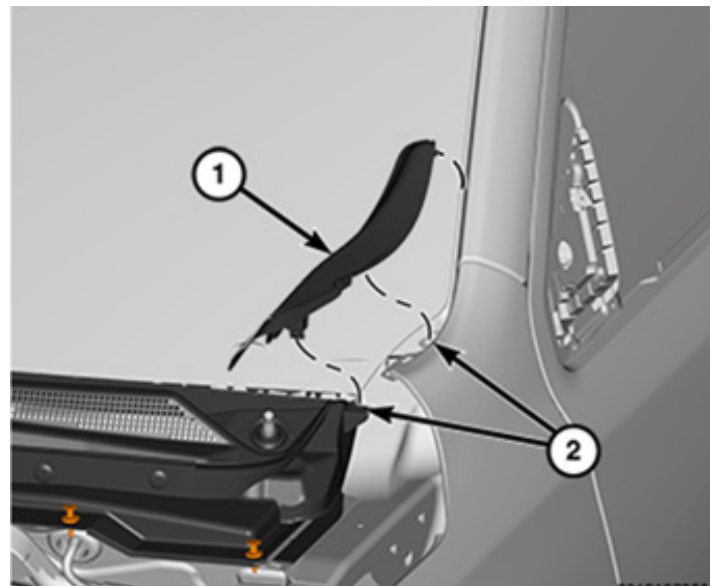

Figure 8

13. Using a plastic panel pry tool, remove the eight (8) push pin retainers. (Figure 9)

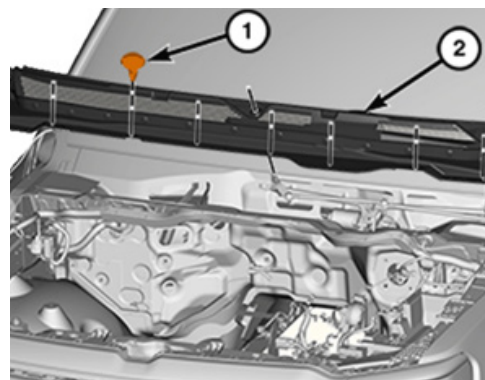

Figure 9

INSTALLATION

14. Slide the wiper cowl slightly forward releasing it from the front windshield lip and remove the cowl from the vehicle.

Hood Hinge Installation; NOTE: Both driver side and passenger side brackets install mirrored in the same way

15. Press the included brass bushing into the upper hole in the upper bracket arm (22065). (Figure 10) (50113-HW)

16. Insert the $\frac{3}{8}$ "-16 yellow zinc bolt, flat washer and brass thrust washer into the brass bushing as shown forming the upper bracket arm assembly. (Figure 10) (50113-HW)

17. Insert the upper bracket arm assembly into the front hole in the lower bracket.

NOTE: Be mindful that the brass thrust washer doesn't misalign when assembling the upper and lower bracket. The thrust washer will be destroyed if tightened down while misaligned

18. Using a two (2) $\frac{9}{16}$ " socket wrenches and the provided $\frac{3}{8}$ " yellow zinc flat washer and $\frac{3}{8}$ "-16 yellow zinc Nylock nut, fully tighten down the upper and lower bracket assembly. (Figure 10) (50113-HW)

19. Using two (2) $\frac{1}{2}$ " wrenches, the ball joint, and $\frac{5}{16}$ -18 stainless steel Nylock nut, install the ball joint into the upper bracket arm and fully tighten. (22065) (50113-HW)

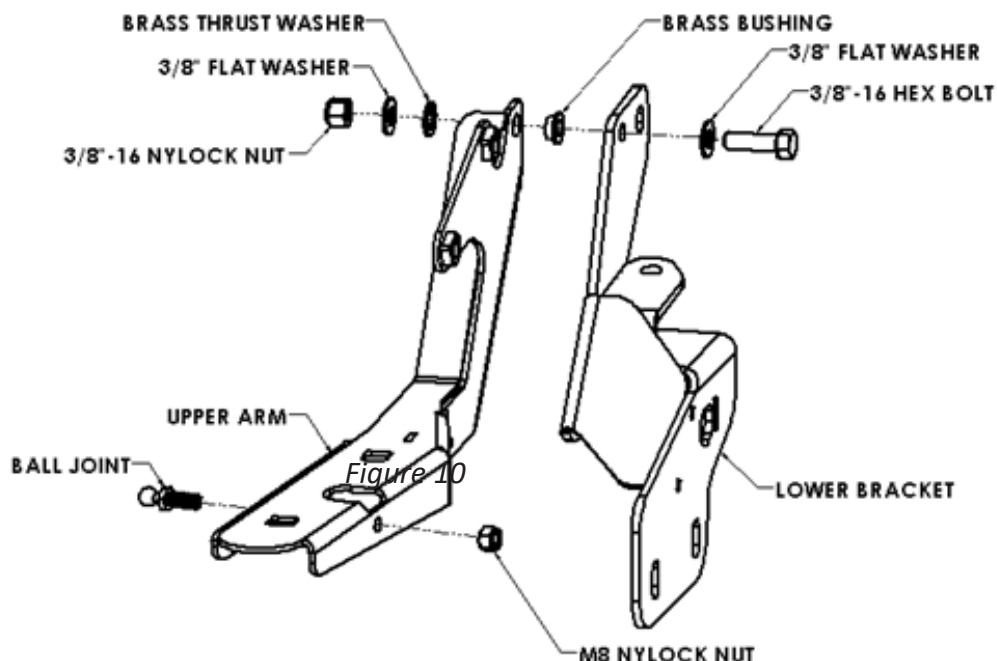

Figure 10

20. Position the driver side bracket as pictured.
(Figure 11)

21. Loosely snug the two factory bolts
securing the bracket to the body side frame.
(Figure 11, #1)

22. Loosely install the provided 5/16"-18 yellow
zinc hex bolt, lock washer, and flat washer.
(Figure 11, #2)

*****Note: do not connect the hood air spring
to the ball joint or fully tighten down the two
factory bolts on the lower bracket yet, these
bolts will be tightened down after the hood has
been reinstalled and final adjustments have
been made. A connected air spring will hinder
bracket adjustment for hood alignment.*****

23. With a friend, lift the hood onto the upper
arm of the hood bracket and install the four
factory nuts hand tight.

24. Lower the hood slowly and check for hood
gap. Latch the hood.

25. Adjust as needed for a uniform hood to
fender gap on both sides.

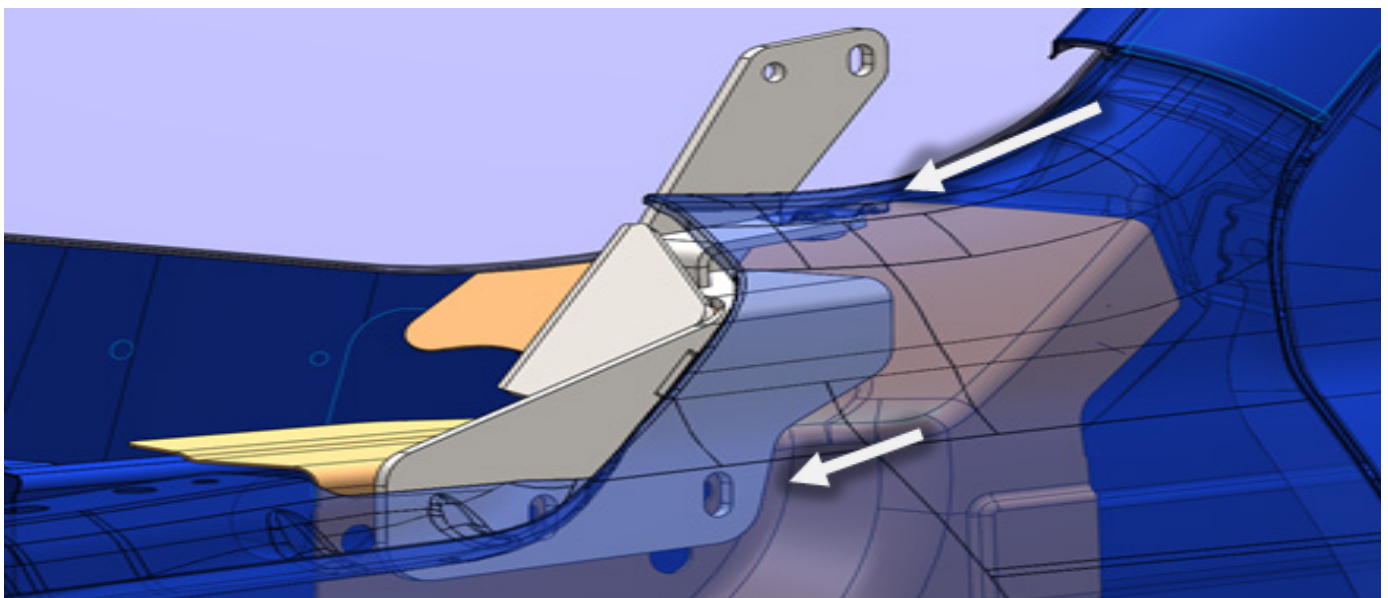

Figure 11

26. Adjust the hood to align the marks made on the blue painter's tape. (Figure 12)

27. Adjust the rear corner of the hood on the driver side by means of raising or lowering the lower hood hinge (22063) for fender fit.

28. Using a 13mm socket wrench, reach up behind the fender through the wheel well opening and fully tighten down the two (2) Oem hood hinge bolts securing the lower hood hinge to the body side frame rail. (Figure 11, #1)

29. Perform step 27-28 on the passenger side.

30. Recheck the hood to fender body lines and adjust as needed

Note: Be mindful of how high you raise the hood while making adjustments to alignment. It is possible that the hood will shift without your knowledge if hood is raised too high prior to tightening the four (4) hood to hood hinge nuts.

31. Slowly raise the hood just enough to reach in with a ratchet and fully tighten down the four factory bolts securing the hood.



Figure 12

*****Note:** The fender bolting tab will need to be bent slightly in order to get the top front of the fender aligned with the hood. The top of the fender near the A-pillar may need to be pushed in as well to align with the A-pillar. Perfect alignment is not necessary as the Vicowl arms conceal the area.

18. Using a ½" socket wrench, align the upper curve of the fender to the hood and fully tighten down the 5/16"-18 hex bolt. (Figure 13)



Figure 13

33. Raise the hood fully and reconnect the gas assist springs on the ball joint on the hinge upper bracket arm (22065). (Figure 14)



Figure 14

34. Relocate the windshield wiper fluid line clips by sliding them along the line and secure the line to the upper bracket arm (22065) and firewall. (Figure 15)

ViCowl Pre-Assembly ***Note: It's highly recommended that all projection weld nuts are chased with the appropriate taps to clean out any powder coat or foreign debris prior to assembly. Tap sizes needed to do this are ½"-13, and ⅜"-16***



Figure 15

35. Install and hand tighten the rubber bumpers and ½" flat washers to the visor (22061). (Figure 16)

36. Install loosely the Visor trim (21313) (or light insert if purchased) into the back of the visor (22061) using the provided 5/16"-18 stainless steel bolts, rubber bonded washer, flat washer, and 5/16"-18 Nylock nut. (50113-HW)

NOTE: The rubber bonded washer is used on the outside surface of the visor to reduce any powder coat wear marks what would otherwise be created using regular flat washers and visible if bolts are moved due to reassembly of visor with light insert.

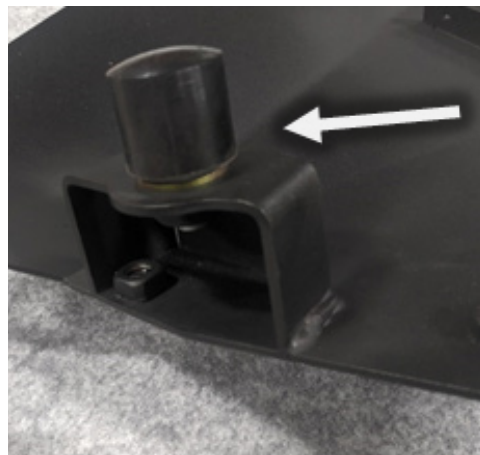

Figure 16

37. Using a 3/16" Allen wrench and ½" wrench, fully tighten down the 5/16"-18 button head bolts securing the visor trim (21313) to the visor (22061).

*****Note: leave about a 1/8" reveal on the edge of the arms. This will ensure the rubber strip doesn't shift or show after installation.*****

33. Install the provided 1" neoprene rubber strip (61724) to the inside of both arms (22059,22060). (Figure 17)



Figure 17

39. Loosely install both ViCowl arms to the visor using the provided 3/8"-16 stainless steel bolts and rubber bonded washers. (Figure 18) (50113-HW)



Figure 18

***** Note: don't stretch the seal as you apply it to the Cowl. This will ensure it doesn't pull away from the sheet metal later.*****

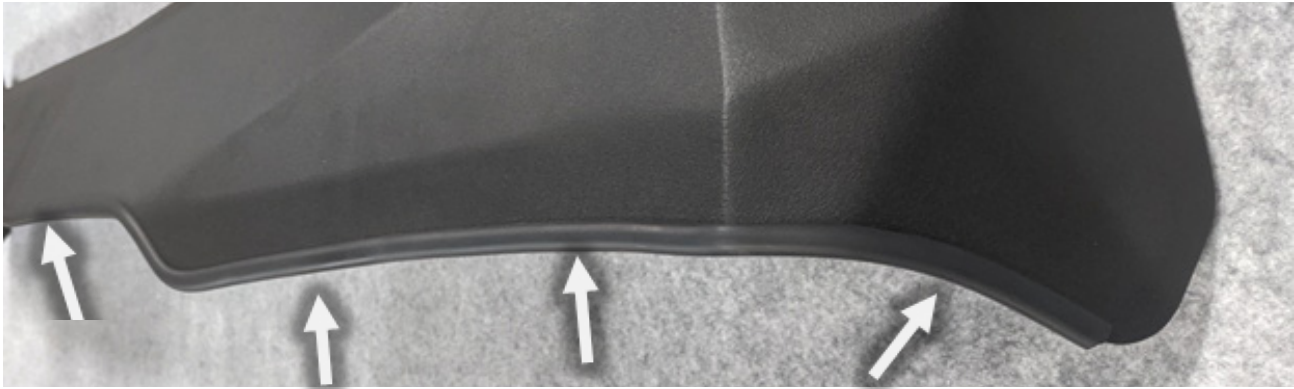

Figure 19

40. Install the edge seal with adhesive onto the leading edge of the cowl. (Figure 19)

41. Using snips, trim the edge seal for fit and finish. (Figure 19)

42. With a friend on the other arm, lift the upper ViCowl assembly up over the hood and behind the radio antenna and slowly lower the arms into position. The arm mounting bracket (22059,22060) rest to the outside of the lower hinge (22063,22064) and lined up with the rear bolt hole. (Figure 20)

43. Loosely install the provided $\frac{3}{8}$ "-16 yellow zinc hex bolt, yellow zinc lock washer, and yellow zinc flat washer through the lower hinge bracket (22063,22064) and into the arms (22059,22060) securing the ViCowl from falling lower on the vehicle.

NOTE: The slot in the bracket is for ease of installation of the bolt only. The bolt should be seated at the bottom of the slot when fully tightened. Failure to do so could result in a smaller gap between the arm and cowl when installation is complete.

44. Check for fit around fenders, A-pillar, and windshield and fully tighten down both arms (22059,22060) to the hinge brackets (22063,22064).

NOTE: A high degree of accuracy is needed when marking the Rivnut locations. The four Rivnuts constitute a majority percentage of the mounting strength of the upper ViCowl to the vehicle. A hole center punch is recommended followed by incremental pilot holes to the finish hole size of the included $\frac{17}{32}$ " drill bit. You will have trouble lining up all three bolt holes per side if Rivnuts are misplaced.



Figure 20

45. Using a locating center punch and hammer, mark the four (4) Rivnut hole locations on both driver and passenger arms (22059,22060). (Figure 21)

46. Remove the upper ViCowl assembly in preparation to drill and install four Rivnuts in the fenders.



Figure 21

47. Use the 1/8" Drill bit to drill pilot holes in all of the marked locations. Be careful to drill directly perpendicular to the side of the vehicle. Be sure to drill the holes to a depth of 7/8". In some instances, this will require drilling through multiple layers of sheet metal.

48. Step up to the 1/4" drill bit.

49. Finally drill out the holes with the provided 17/32" drill bit. (50113-HW) If available, a sheet metal Uni- Bit or step drill bit can be used after the 1/4" bit.

NOTE: The fender needs to be pulled away slightly in order to allow clearance for the riv nut tool at the rear nutsert hole near the door jam. Opening the door exposes a 10mm bolt to be removed then reinstalled after the nutsert is installed.

50. With the expendable tool threaded into the nutsert, insert it into one of the holes making sure that it fits in far enough to flush the collar of the nutsert to rocker panel. (For an exceptional installation, coat the knurls of the Nutsert with Loc-tite.)

NOTE: Tighten the bolt into the nutsert until it becomes snug in the fender. DO NOT OVERTIGHTEN CAUSING THE INSERT TO SPIN!

51. Place the 9/16" Box end wrench on the body of the expendable tool and the 9/16" socket and ratchet on the bolt head on the back side of the tool. (Figure 22)

52. Repeat steps 33-37 for the remaining nutserts. (Figure 23)



Figure 22

53. Repeat steps 28-30 to reinstall the upper Vicowl assembly to the vehicle. (Figure 20)

54. Using a 7/32" Allen wrench, install and fully tighten the provided 3/8"-16 stainless steel button head bolts, stainless steel rubber bonded washers, and blue Locktight. (50113-HW)



Figure 23

55. Using a 7/32" Allen wrench and 9/16" socket wrench, fully tighten down the four (4) lower arm stainless steel button head bolts, two (2) yellow zinc hex bolts, and six (6) upper stainless steel button head bolts securing the arms (22059,22060) to the fenders and visor (22061). (Figure 24)

56. With assistance, lift the ViCowl cowl (22062) up over the hood and slowly lower it down between the upper bracket arm mounting surfaces. (Figure 25)

57. Loosely install the provided four (4) 3/8"-16 yellow zinc hex nuts, yellow zinc lock washer, and yellow zinc flat washer through the cowl mounting plates (22062) and into the upper bracket arm projection nuts (22065,22066). (50113-HW)

58. Using an impact wrench or ratchet, extension, swivel, and 9/6" socket, fully tighten down the front cowl bolt on the driver side while pressing down on the cowl (22062) to close any gap between the cowl and hood
59. Repeat step 44 for the front bolt on the passenger side of the cowl.

60. Using the impact wrench assembly, fully tighten the rear bolts on both the driver and passenger side of the cowl (22062).



Figure 24



Figure 25

61. A space should be present between both arms and cowl. (Figure 26)

62. Raise the hood and check for cowl (22062) to arm (22059,22060) clearances.

*** Note: Both ends of the cowl need to be trimmed so the ViCowl brackets clear the cowl in the down position. Some minor additional trimming may be needed along the marked cut lines.***



Figure 26



Figure 27

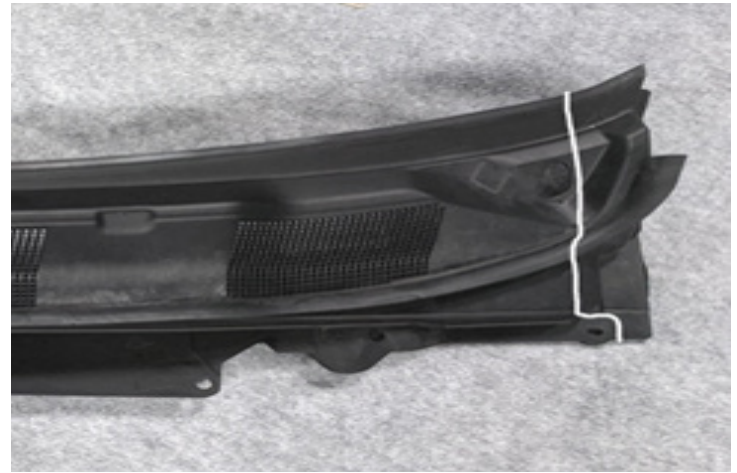

Figure 28



Figure 29



Figure 30

63. Trim off the areas shown on both sides of the cowl. (Figure 27-30)

64. Reinstall the wiper cowl in an opposite manner than the removal with the eight (8) OEM push pins.

65. Using a 15mm socket wrench, reinstall the wiper arms.

CONTACT INFORMATION

**FAB FOURS INC.
2213 INDUSTRIAL PARK ROAD
LANCASTER, SC 29720**

PHONE: (866) 385-1905

FAX: 970-385-1914

EMAIL: SUPPORT@FABFOURS.COM

FABFOURS.COM



**“IF YOU’RE LOOKING FOR MORE OF THE SAME,
THEN YOU’VE COME TO THE WRONG PLACE.”**

- GREG HIGGS

