

WARNING

A warning indicates a potentially hazardous situation which, if not avoided, could result in death or serious injury.

1. Read all instructions and save them for later reference.
2. Follow all warnings and instructions marked on the product.
3. Do not stand on the Versahaul.
4. Do not ride any vehicle during loading.
5. Store the Versahaul carrier in a safe place.
6. Do not exceed vehicle tongue weight rating.
7. Only use with a Class III/IV hitch. Most Class III hitches limit Versahaul to 500 lbs. total hauling capacity, while most Class IV hitches are rated for 1000 lbs.
8. Improper use of carrier could result in death or serious injury.
9. Do not put Versahaul onto a 5th wheel trailer or any other kind of trailer.
10. **VH-Sport carrying capacity is limited to 600 lbs. max, while VH-55 carrying capacity is limited to 500 lbs. max. Your vehicle suspension and hitch may further limit the hauling capacity of the carrier.** For more information on vehicles and hauling capacities, visit www.versahaul.com.

Manufacturer Information

Manufacturer's Name: BNK, Inc.

Manufacturer's Address:

BNK, Inc.
9341 S. St. Rd. 39
Winamac, IN 46996
(888) 818-9915

Product Name: Versahaul Wheel Chock

Product Description: Motorcycle Chock Upgrade for VH-55 and VH-Sport Carriers

Model Number: VH-Chock

VH-CHOCK INSTRUCTION BOOKLET

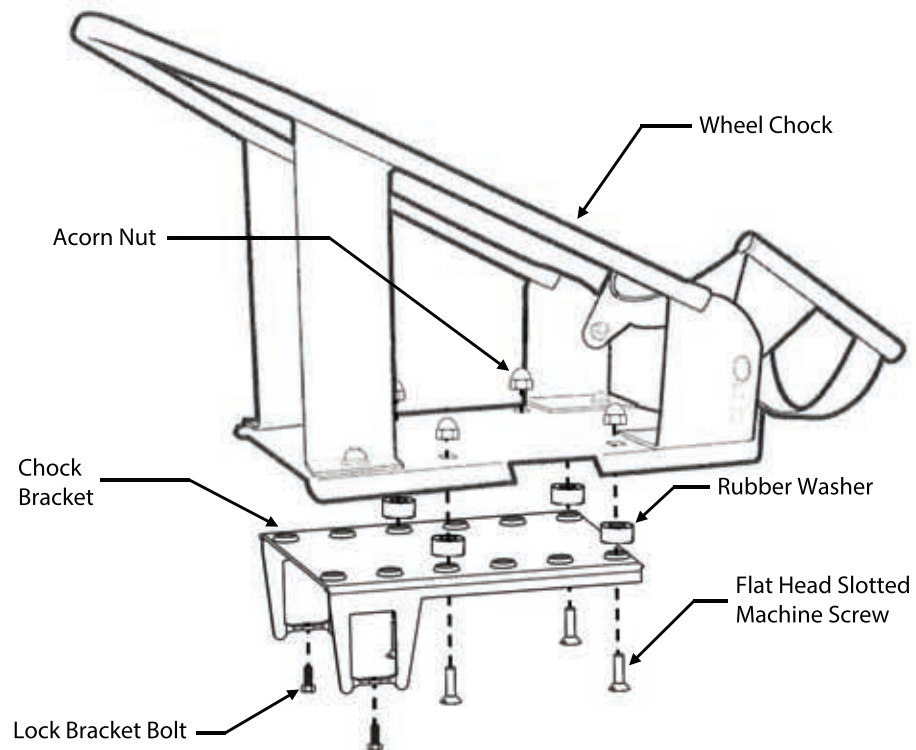

Parts List:



x1 Wheel Chock

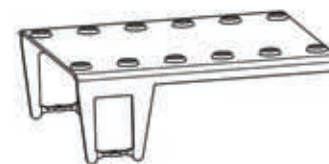

x1 Chock Bracket



x2 Lock Bracket Bolts
1/4" x 3/4"



x4 Flat Head Slotted
Machine Screws
3/8" x 1-1/4"



x4 Rubber Washers



x4 Acorn Nuts

Step 1

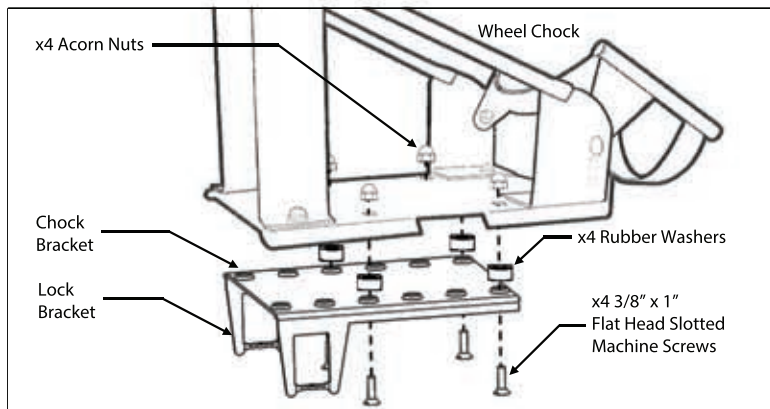

Fasten the Wheel Chock to the Chock Bracket using the 4 included 3/8" x 1" Flat Head Slotted Machine Screws. Insert these Screws up through the bottom of the Chock Bracket. **Note:** These Screws may be placed in different holes to adjust the length of the Wheel Chock, but should always remain 3 holes apart to properly align with the holes in the Wheel Chock. After inserting the Screws, place a Rubber Washer around each on the top side of the Chock Bracket. Place the Wheel Chock on top of the Chock Bracket so that the Screws fit through the 4 holes in the Wheel Chock base. Screw an Acorn Nut on top of each.

Step 2

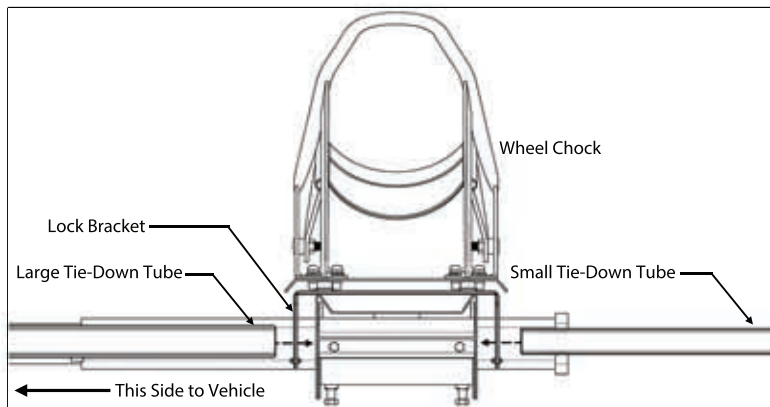

After removing the Tie-Down Tubes, center the completed Wheel Chock assembly over the main rail. Reinsert the Tie-Down Tubes all the way through the Lock Brackets and tie-down holes in the rail. The Small Tie-Down Tube should slide into the Large Tie-Down Tube such that the snap pin holes in each align.

Step 3

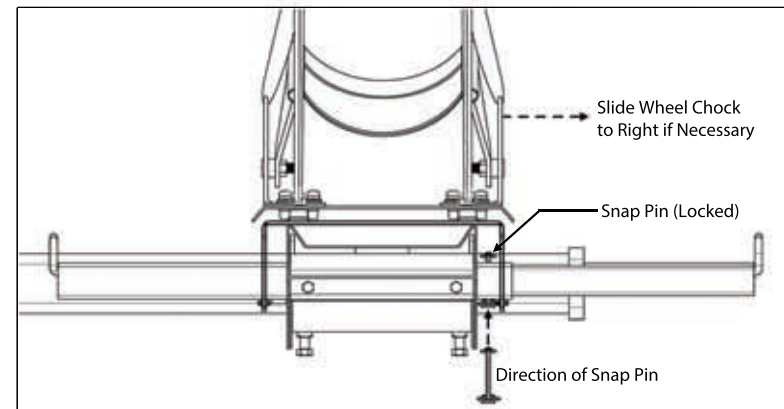

Insert Snap Pin up through the aligned holes in each Tie-Down Tube. In order to most easily lock Snap Pin, the Wheel Chock may be slid out from the Snap Pin to make room. Make sure to recenter the Wheel Chock back over the main rail once the Snap Pin is locked.

Step 4

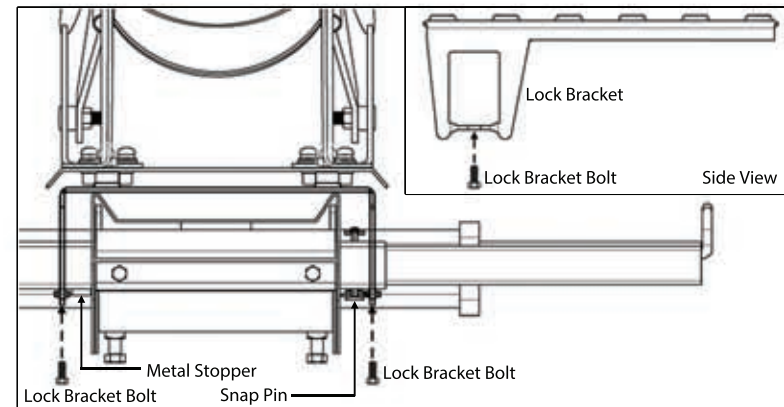

Finally, insert the (2) 1/4" x 3/4" Lock Bracket Bolts up through the Lock Brackets so that they clamp against the bottom of the Large Tie-Down Tube. The left Lock Bracket Bolt should set just outside of the Metal Stopper, and the right Lock Bracket Bolt should set just outside of the Snap Pin on the Large Tie-Down Tube.